

NSK Ball Screws for High-Load Drive

TAC Series of Ball Screw Support Bearings for High-Load Applications NSK Roller Guide RA Series

We have developed easy-to-use ball screws for high-load applications and now offer a wide variety of products suited for high-load drives.

These ball screws enable the electric servo drive to operate under the most severe conditions.



Lineup of NSK Ball Screws for High-Load Drive

Best suited design for high-load applications

The best arrangement of the ball recirculation circuits and use of the largest possible ball have significantly contributed to the enhancement of high-load bearing characteristics. (Refer to pages 31 and 32 for details.)

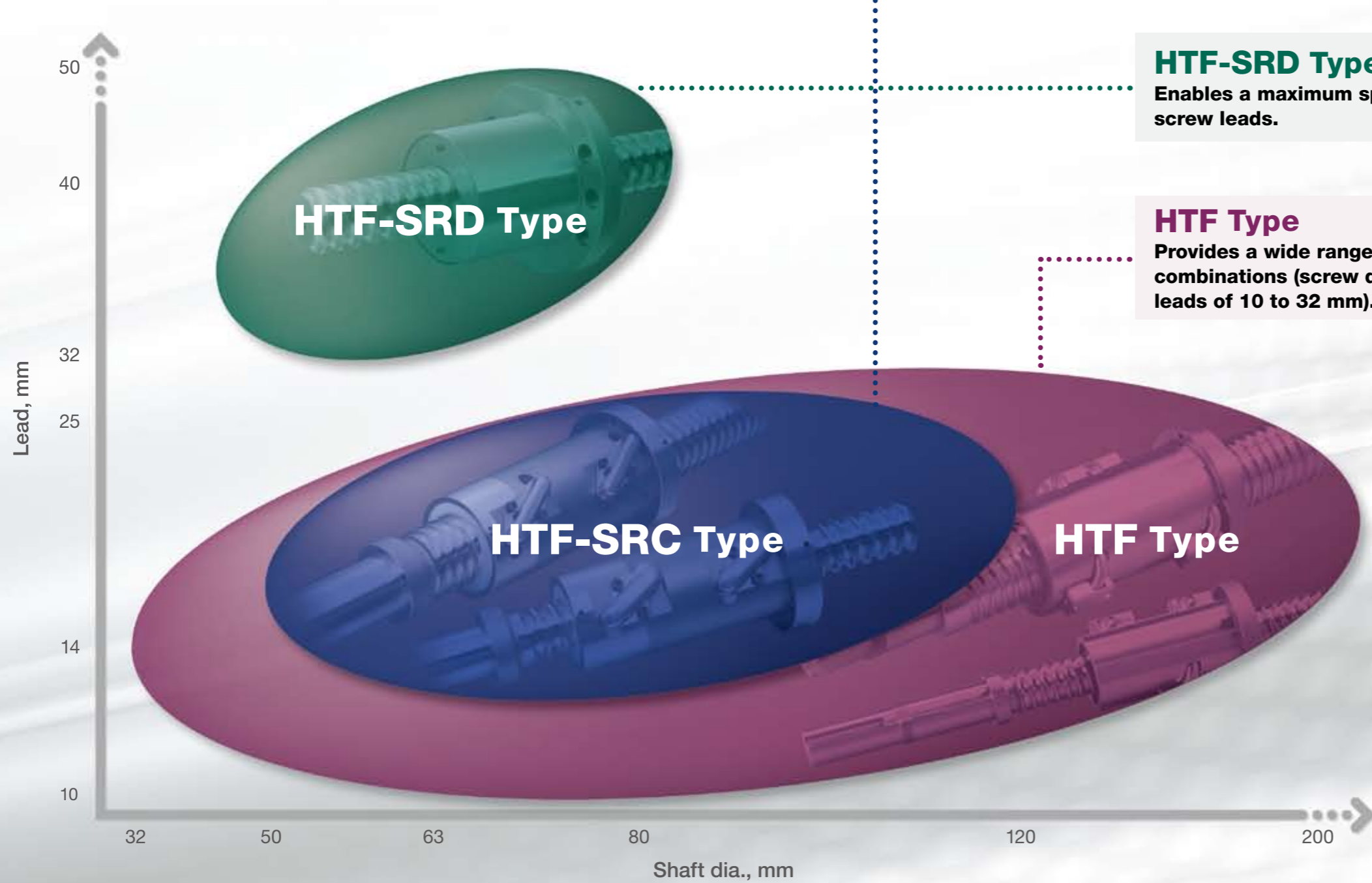

HTF-SRC Type
 Enables a maximum speed of 930 mm/s with fine screw leads.
 P 3
 :
 P 6

HTF-SRD Type
 Enables a maximum speed of 1 600 mm/s with coarse screw leads.
 P 7
 :
 P 10

HTF Type
 Provides a wide range of screw diameter and lead combinations (screw diameters of 32 to 200 mm and leads of 10 to 32 mm).
 P 11
 :
 P 22

Equipped with Grease Retaining A1 Seals
 Optimized design of A1 seal enables superior grease retaining performance.
 P 23
 :
 P 28

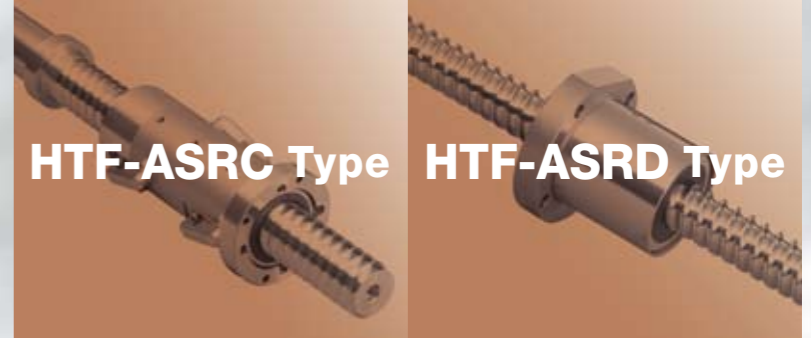

HTF-SRC Type

1 Specifications

Recirculation system: Equipped with SRC (Smooth Return Coupling)

The new ball recirculation system incorporates an end deflector. It picks up balls in the direction they are moving, thus contributing to more than twice the feed speed and less than half the noise level compared with those of the existing ball screws equipped with a return tube.

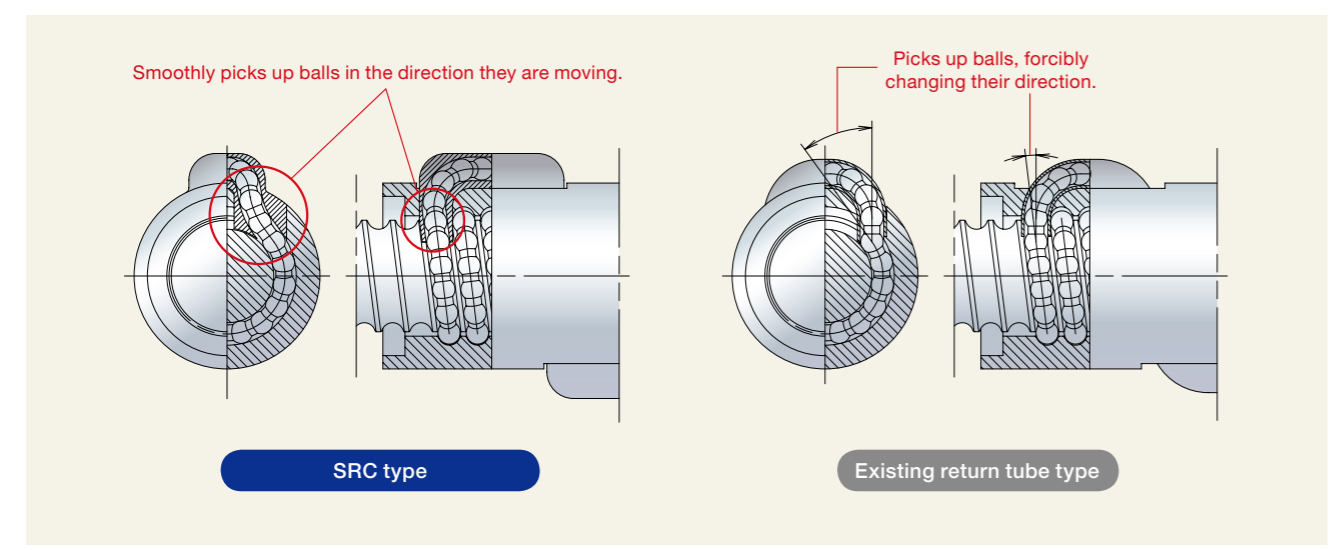

Allowable d·n value and feed speed

Lead 14 and 16 mm: 160 000 or less
 Lead 20 and 25 mm: 140 000 or less
 d·n: Shaft diameter d (mm) × Rotational speed n (min⁻¹)

Allowable feed speed of combinations of shaft diameter and lead Unit: mm/s

Lead (mm) \ Shaft dia. (mm)	14	16	20	25
50	750	860	—	—
63	—	680	740	930
80	—	540	590	730
100	—	—	470	590
120	—	—	390	490

High-speed performance two times greater than existing products

Noise reduced by 6 dB (A) or more compared with return tube type

Accuracy grade

Ct7 of JIS B 1192 (1997) is applicable as the standard accuracy grade.

Axial play

Standard axial play: 0.020 mm or less, or 0.050 mm or less

Other

Please consult NSK for special requests.
 Examples:

- Add a recirculation circuit to increase the load capacity.
- Position all recirculation circuits on the same phase of ball nut circumference.

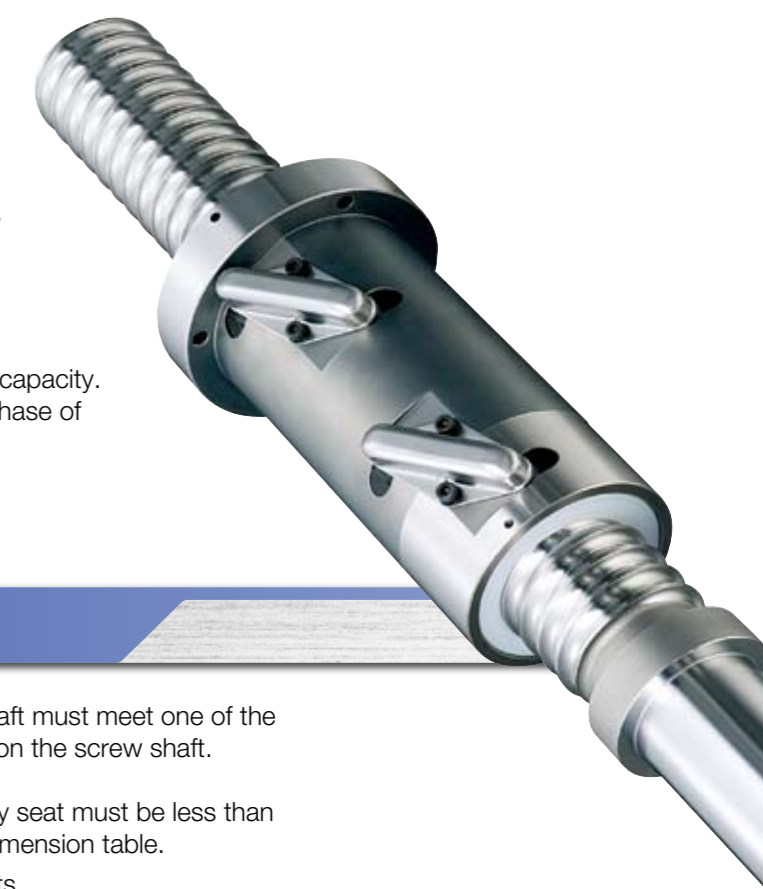

2 Design Precautions

- 1) When designing the shaft ends, one end of the screw shaft must meet one of the following conditions. If not, we cannot install the ball nut on the screw shaft.
 - The ball groove is cut through to the shaft end.
 - The diameters of bearing journals and the gear or pulley seat must be less than the root diameter of ball groove "dr" specified on the dimension table.
- 2) Please consult NSK with your special design requirements.

3 Selection of Ball Screw

- Please refer to pages 33 and 34 for details on the operating life of the ball screw and instructions on installation and lubrication.
- Please consult NSK in the case of a short stroke operation less than or equal to four times the length of the ball screw lead.

4 Operating Temperature

- Maximum operating temperature: 70°C (at outside diameter of ball nut)

HTF-SRC Type

Outline drawing

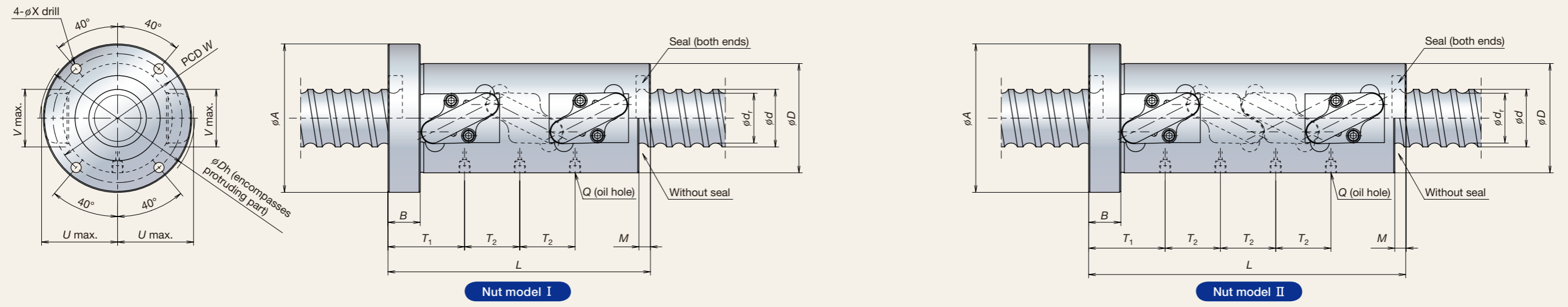

HTF-SRC Type Specifications

Model No.	Lead (mm) l	Shaft dia. (mm) d	Root dia. (mm) d_r	Effective ball turns Turns \times Circuits	Nut model	Basic load rating (kN)		Ball nut dimensions (mm)												Allowable axial load F_a max. (kN)	
						Dynamic C_a	Static C_{0a}	D	A	B	L	M	W	X	U	V	Dh	Q	T_1		T_2
HTF-SRC5014-7.5	14	50	41.6	2.5x3	I	211	623	80	114	28	202	10	97	9	54.5	46	111	M6x1	69	42	73.1
HTF-SRC5016-7.5	16	50	39	2.5x3	I	306	818	95	129	28	228	10	112	9	66	50	134	Rc1/8	74.5	48	91.1
HTF-SRC6316-7.5	16	63	52	2.5x3	I	343	1 050	105	139	28	228	10	122	9	72.5	50	148	Rc1/8	74.5	48	119.7
HTF-SRC6316-10	16	63	52	2.5x4	II	439	1 410	105	139	28	276	10	122	9	72.5	50	148	Rc1/8	74.5	48	159.6
HTF-SRC6316-10.5	16	63	52	3.5x3	I	450	1 450	105	139	28	276	10	122	9	72.5	50	148	Rc1/8	74.5	64	167.6
HTF-SRC6316-14	16	63	52	3.5x4	II	576	1 930	105	139	28	340	10	122	9	72.5	50	148	Rc1/8	74.5	64	215.0
HTF-SRC8016-10.5	16	80	69	3.5x3	I	501	1 870	120	154	32	278	10	137	9	80	60	165	Rc1/8	78.5	64	221.3
HTF-SRC8016-14	16	80	69	3.5x4	II	642	2 490	120	154	32	342	10	137	9	80	60	165	Rc1/8	78.5	64	295.1
HTF-SRC6320-7.5	20	63	49	2.5x3	I	457	1 280	117	157	32	279	12	137	11	80	62	163	Rc1/8	90	60	147.1
HTF-SRC6320-10	20	63	49	2.5x4	II	586	1 710	117	157	32	339	12	137	11	80	62	163	Rc1/8	90	60	196.1
HTF-SRC8020-10.5	20	80	66	3.5x3	I	671	2 300	130	170	32	339	12	150	11	88	64	180	Rc1/8	90	80	267.4
HTF-SRC10020-10.5	20	100	86	3.5x3	I	749	2 910	145	185	32	339	12	165	11	97	78	199	Rc1/8	90	80	345.9
HTF-SRC10020-14	20	100	86	3.5x4	II	959	3 890	145	185	32	419	12	165	11	97	78	199	Rc1/8	90	80	461.2
HTF-SRC12020-7.5	20	120	106	2.5x3	I	621	2 550	173	213	40	287	12	193	11	109.5	88	229	Rc1/8	98	60	304.6
HTF-SRC12020-10	20	120	106	2.5x4	II	795	3 400	173	213	40	347	12	193	11	109.5	88	229	Rc1/8	98	60	406.1
HTF-SRC6325-10.5	25	63	49	3.5x3	I	600	1 770	117	157	32	405	12	137	11	81.5	61	167	Rc1/8	101.75	100	170.0
HTF-SRC8025-7.5	25	80	63	2.5x3	I	632	1 960	145	185	40	347	17	165	11	99.5	73	202	Rc1/8	111.75	75	221.1
HTF-SRC10025-10.5	25	100	83	3.5x3	I	964	3 430	159	199	40	422	17	179	11	108	79	220	Rc1/8	111.75	100	408.4
HTF-SRC10025-14	25	100	83	3.5x4	II	1 230	4 580	159	199	40	522	17	179	11	108	79	220	Rc1/8	111.75	100	544.6
HTF-SRC12025-10.5	25	120	103	3.5x3	I	1 040	4 200	173	213	40	421	17	193	11	116	92	238	Rc1/8	111.25	100	498.0
HTF-SRC12025-14	25	120	103	3.5x4	II	1 330	5 600	173	213	40	521	17	193	11	116	92	238	Rc1/8	111.25	100	664.0

- Remarks: 1. The ball nut length with no seals is shorter by M than that of a ball nut with seals.
 2. Please consult NSK if load exceeds the allowable axial load (F_a max.).
 3. The allowable axial load (F_a max.) is determined in accordance with the mounting conditions of ball screws recommended by NSK.
 Refer to page 34 for the mounting conditions. If your mounting conditions differ from those provided, please consult NSK.
 4. The right hand screw is the standard. For specifications on left hand screws, contact NSK.

HTF-SRD Type

1 Specifications

Recirculation system: Equipped with end deflector

Used with well accepted end deflectors, HTF-SRD type ball screws achieve the maximum feed speed of 1 600 mm/s. The ball nut body surface is completely round, thus enabling well balanced ball nut rotation.

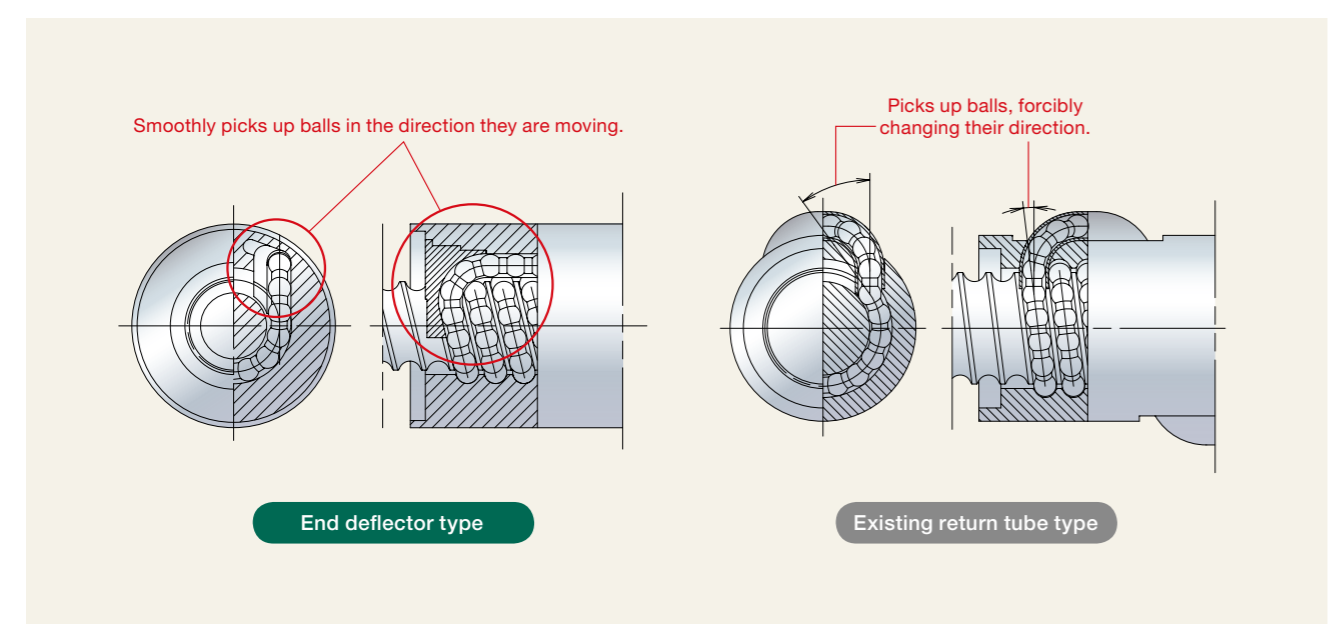

Allowable d·n value and feed speed

d·n: 120 000 or less
 d·n: Shaft diameter d (mm) × Rotational speed (min⁻¹)

Allowable feed speed of combinations of shaft diameter and lead Unit: mm/s

Shaft dia. (mm) \ Lead (mm)	32	40	50
50	—	1 600	—
63	1 000	1 250	—
80	—	—	1 250

High-lead specification optimal for high speed

Noise reduced by 6 dB (A) or more compared with return tube type

Accuracy grade

Ct7 of JIS B 1192 (1997) is applicable as the standard accuracy grade.

Axial play

Standard axial play: 0.020 mm or less, or 0.050 mm or less

Seal

The ball nut length is shortened by the use of thin seals.

Others

Please consult NSK for information on nut rotation.



2 Design Precautions

- When designing the shaft ends, one end of the screw shaft must meet one of the following conditions. If not, we cannot install the ball nut on the screw shaft.
 - The ball groove is cut through to the shaft end.
 - The diameters of bearing journals and the gear or pulley seat must be less than the root diameter of ball groove "dr" specified on the dimension table.
- Please consult NSK with your special design requirements.

3 Selection of Ball Screw

- Please refer to pages 33 and 34 for details on the operating life of the ball screw and instructions on installation and lubrication.
- Please consult NSK in the case of a short stroke operation less than or equal to four times the length of the ball screw lead.

4 Operating Temperature

- Maximum operating temperature: 70°C (at outside diameter of ball nut)

HTF-SRD Type

Outline drawing

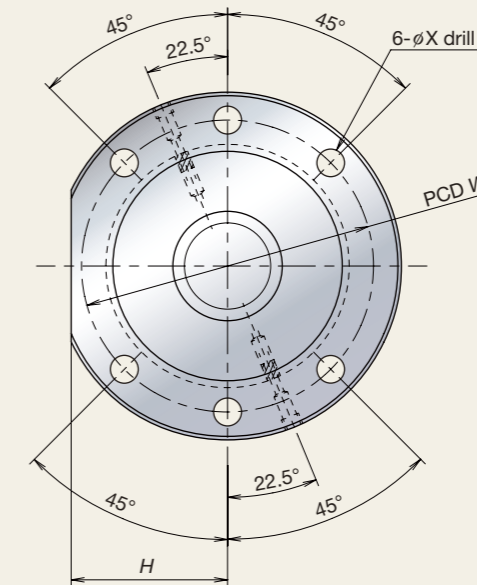
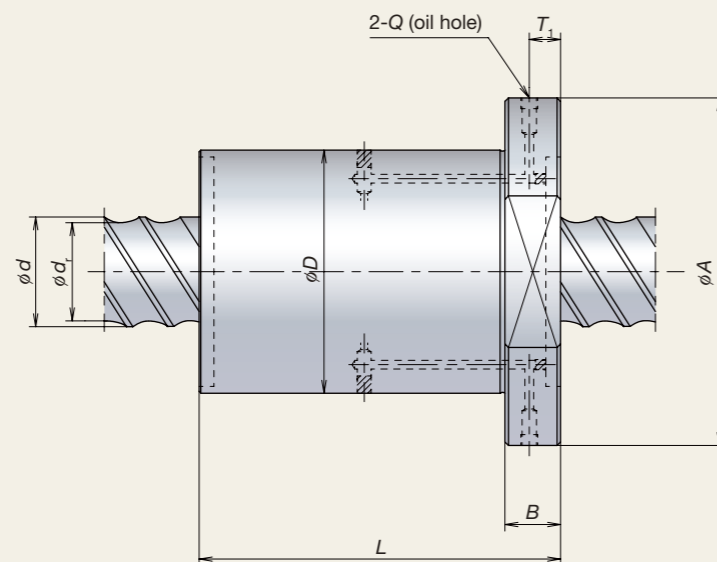

HTF-SRD Type Specifications

Model No.	Lead (mm) ℓ	Shaft dia. (mm) d	Root dia. (mm) d_r	Basic load rating (kN)		Ball nut dimensions (mm)									Allowable axial load F_a max. (kN)
				Dynamic C_a	Static C_{0a}	D	A	B	L	H	W	X	Q	T_1	
HTF-SRD6332-4E	32	63	49	233	590	140	190	32	176	85	165	14	Rc1/8	19.5	72.6
HTF-SRD5040-6E	40	50	39	195	491	115	165	28	159	72.5	140	14	Rc1/8	16	67.6
HTF-SRD5040-8E	40	50	39	255	679	115	165	28	199	72.5	140	14	Rc1/8	16	92.0
HTF-SRD6340-6E	40	63	49	291	768	140	200	32	163	90	170	18	Rc1/8	18	106.3
HTF-SRD6340-8E	40	63	49	381	1 060	140	200	32	203	90	170	18	Rc1/8	18	144.7
HTF-SRD8050-6E	50	80	63	401	1 180	175	250	40	194	110	210	22	Rc1/8	24	163.7
HTF-SRD8050-8E	50	80	63	526	1 630	175	250	40	244	110	210	22	Rc1/8	24	224.1

Remarks: 1. Please consult NSK if load exceeds the allowable axial load (F_a max.).
 2. The right hand screw is the standard. For specifications on left hand screws, contact NSK.
 3. The allowable axial load (F_a max.) is determined in accordance with the mounting conditions of ball screws recommended by NSK. Refer to page 34 for the mounting conditions. If your mounting conditions differ from those provided, please consult NSK.

HTF Type

1 Specifications

Recirculation system: Ball return tube

Allowable d·n value and feed speed

Lead and allowable d·n value

Lead	20 mm or less	25 mm	30 to 32 mm
Standard	70 000 or less	70 000 or less	50 000 or less
High-speed	100 000 or less	—	—

d·n: Shaft diameter d (mm) × Rotational speed (min⁻¹)

Allowable feed speed of combinations of shaft diameter and lead Unit: mm/s

Shaft dia. (mm)	Lead (mm)							
	10	12	14	16	20	25	30	32
32	520							
36	460	550						
40	410	500						
45	370	440						
50	330	400	460	530				
55	300	360	420	480				
63		310	370	420	520			
80			290	330	410	360		
100				260	330	290		
120				220	270	240		
140					230	200	170	190
160						180	150	160
200							120	130

Accuracy grade

Ct7 of JIS B 1192 (1997) is applicable as the standard accuracy grade.

Axial play

Standard axial play: 0.020 mm or less, or 0.050 mm or less

Others

Please consult NSK for special requests.

- Examples:
- Add a recirculation circuit to increase the load capacity.
 - Position all recirculation circuits on the same phase of ball nut circumference.

2 Design Precautions

- 1) When designing the shaft ends, one end of the screw shaft must meet one of the following conditions. If not, we cannot install the ball nut on the screw shaft.
 - The ball groove is cut through to the shaft end.
 - The diameters of bearing journals and the gear or pulley seat must be less than the root diameter of ball groove “dr” specified on the dimension table.
- 2) Please consult NSK with your special design requirements.

3 Selection of Ball Screw

- Please refer to pages 33 and 34 for details on the operating life of the ball screw and instructions on installation and lubrication.
- Please consult NSK in the case of a short stroke operation less than or equal to four times the length of the ball screw lead.

4 Operating Temperature

Maximum operating temperature: 70°C (at outside diameter of ball nut)



HTF Type

Outline drawing

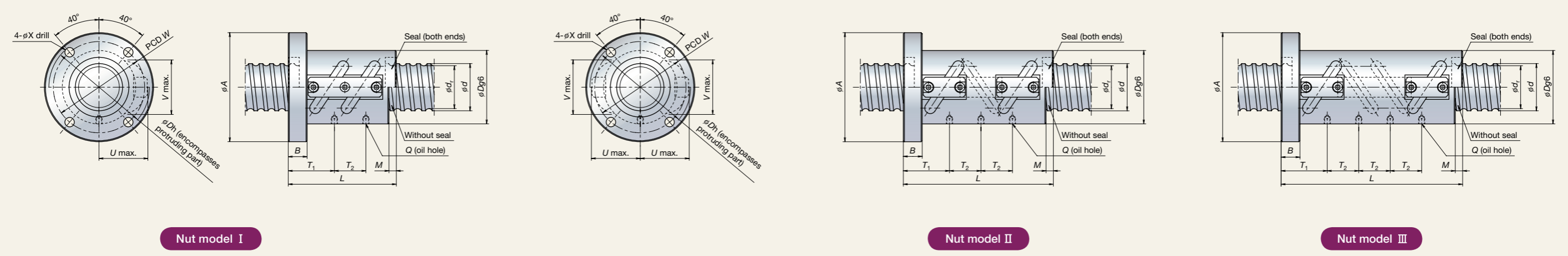

Nut model I

Nut model II

Nut model III

HTF Type Specifications

Model No.	Lead (mm) ℓ	Shaft dia. (mm) d	Root dia. (mm) d_r	Effective ball turns Turns x Circuits	Nut model	Basic load rating (kN)		Ball nut dimensions (mm)													Allowable axial load F_a max. (kN)
						Dynamic C_a	Static C_{0a}	D	A	B	L	M	W	X	U	V	D_h	Q	T_1	T_2	
HTF3210-5	10	32	25.6	2.5x2	I	71	169	58	92	18	103	7	75	9	40.5	42	82	M6x1	36.5	30	20.3
HTF3610-5	10	36	29.6	2.5x2	I	76.9	191	62	96	18	103	7	79	9	43	45	87	M6x1	36.5	30	23.4
HTF4010-7.5	10	40	33.6	2.5x3	II	120	344	66	100	18	143	7	83	9	45	48	91	M6x1	46.5	30	39.6
HTF4510-7.5	10	45	38.6	2.5x3	II	127	386	70	104	18	143	7	87	9	47	52	95	M6x1	46.5	30	45.3
HTF4510-10	10	45	38.6	2.5x4	III	162	514	70	104	18	173	7	87	9	47	52	95	M6x1	46.5	30	60.4
HTF5010-7.5	10	50	43.6	2.5x3	II	133	435	75	109	18	143	7	92	9	49	57	99	M6x1	46.5	30	51.0
HTF5010-10	10	50	43.6	2.5x4	III	170	580	75	109	18	173	7	92	9	49	57	99	M6x1	46.5	30	68.0
HTF5510-7.5	10	55	48.6	2.5x3	II	139	477	80	114	18	143	7	97	9	51.5	62	104	M6x1	46.5	30	55.7
HTF5510-10	10	55	48.6	2.5x4	III	178	636	80	114	18	173	7	97	9	51.5	62	104	M6x1	46.5	30	74.2
HTF3612-5	12	36	29	2.5x2	I	90	228	66	100	22	123	8	83	9	46.5	46	94	M6x1	44	36	28.3
HTF4012-7.5	12	40	33	2.5x3	II	147	422	70	104	22	171	8	87	9	47.5	50	96	M6x1	56	36	48.0
HTF4512-7.5	12	45	38	2.5x3	II	156	473	72	106	22	171	8	89	9	49.5	54	100	M6x1	56	36	55.0
HTF5012-7.5	12	50	43	2.5x3	II	164	525	77	111	22	171	8	94	9	52	59	105	M6x1	56	36	62.0
HTF5012-10	12	50	43	2.5x4	III	210	700	77	111	22	207	8	94	9	52	59	105	M6x1	56	36	82.7
HTF5512-7.5	12	55	48	2.5x3	II	171	586	82	116	22	171	8	99	9	54.5	63	110	M6x1	56	36	69.1
HTF5512-10	12	55	48	2.5x4	III	220	781	82	116	22	207	8	99	9	54.5	63	110	M6x1	56	36	92.1
HTF6312-7.5	12	63	56	2.5x3	II	181	668	92	126	22	171	8	109	9	58.5	70	118	M6x1	56	36	80.3
HTF6312-10	12	63	56	2.5x4	III	232	891	92	126	22	207	8	109	9	58.5	70	118	M6x1	56	36	107.1

Remarks: 1. The ball nut length with no seals is shorter by M than that of a ball nut with seals.
 2. Please consult NSK if load exceeds the allowable axial load (F_a max.).
 3. The allowable axial load (F_a max.) is determined in accordance with the mounting conditions of ball screws recommended by NSK.
 Refer to page 34 for the mounting conditions. If your mounting conditions differ from those provided, please consult NSK.

HTF Type

Outline drawing

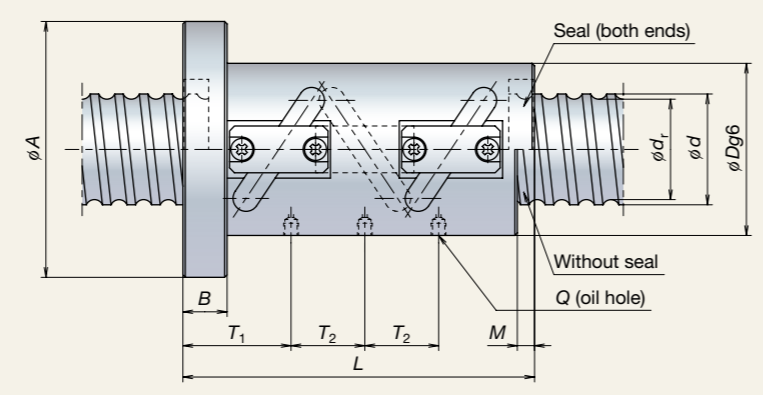
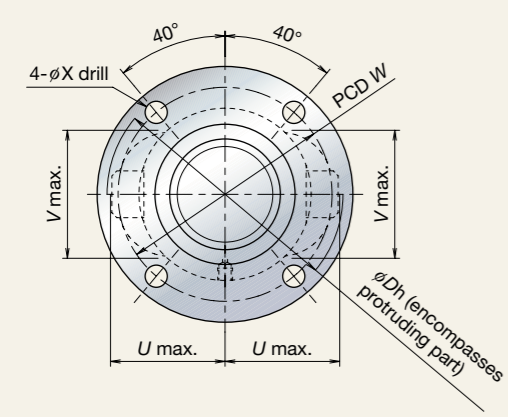

Nut model II

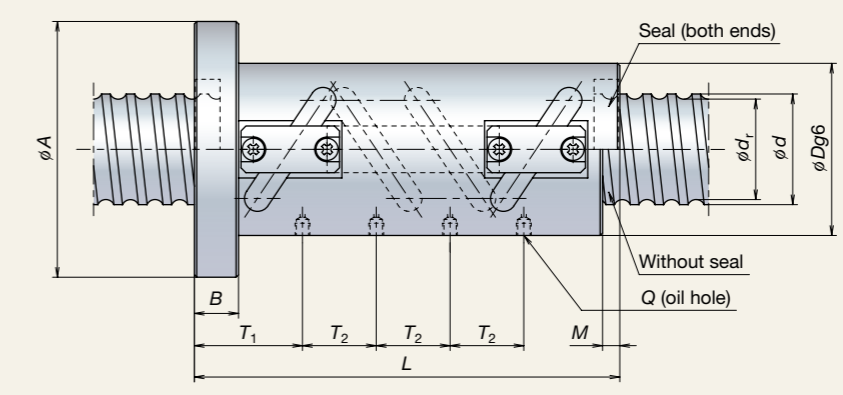

Nut model III

HTF Type Specifications

Model No.	Lead (mm) ℓ	Shaft dia. (mm) d	Root dia. (mm) d_r	Effective ball turns Turns x Circuits	Nut model	Basic load rating (kN)		Ball nut dimensions (mm)												Allowable axial load F_a max. (kN)	
						Dynamic C_a	Static C_{0a}	D	A	B	L	M	W	X	U	V	D_h	Q	T_1		T_2
HTF5014-7.5	14	50	41.7	2.5x3	II	211	623	80	114	28	200	10	97	9	55.5	61	112	M6x1	66.5	42	73.1
HTF5514-7.5	14	55	46.7	2.5x3	II	216	696	85	119	28	200	10	102	9	57.5	65	116	M6x1	66.5	42	81.2
HTF6314-7.5	14	63	54.7	2.5x3	II	233	800	94	128	28	200	10	111	9	61.5	72	124	M6x1	66.5	42	93.5
HTF6314-10	14	63	54.7	2.5x4	III	298	1 070	94	128	28	242	10	111	9	61.5	72	124	M6x1	66.5	42	124.7
HTF8014-7.5	14	80	71.7	2.5x3	II	261	1 020	116	150	28	200	10	133	9	72	87	146	M6x1	66.5	42	121.9
HTF8014-10	14	80	71.7	2.5x4	III	335	1 360	116	150	28	242	10	133	9	72	87	146	M6x1	66.5	42	162.5
HTF5016-7.5	16	50	39	2.5x3	II	306	818	95	129	28	223	10	112	9	68	66	137	Rc1/8	73	48	91.1
HTF5516-7.5	16	55	44	2.5x3	II	319	922	99	133	28	223	10	116	9	70	70	141	Rc1/8	73	48	101.9
HTF6316-7.5	16	63	52	2.5x3	II	343	1 050	105	139	28	223	10	122	9	72.5	76	146	Rc1/8	73	48	119.7
HTF6316-10	16	63	52	2.5x4	III	439	1 410	105	139	28	271	10	122	9	72.5	76	146	Rc1/8	73	48	159.6
HTF6316-10.5	16	63	52	3.5x3	II	450	1 450	105	139	28	271	10	122	9	72.5	76	146	Rc1/8	73	64	167.6
HTF6316-14	16	63	52	3.5x4	III	576	1 930	105	139	28	335	10	122	9	72.5	76	146	Rc1/8	73	64	215.0
HTF8016-7.5	16	80	69	2.5x3	II	382	1 340	120	154	32	227	10	137	9	80	92	161	Rc1/8	77	48	159.0
HTF8016-10	16	80	69	2.5x4	III	490	1 790	120	154	32	275	10	137	9	80	92	161	Rc1/8	77	48	212.0
HTF8016-10.5	16	80	69	3.5x3	II	501	1 870	120	154	32	275	10	137	9	80	92	161	Rc1/8	77	64	221.3
HTF8016-14	16	80	69	3.5x4	III	642	2 490	120	154	32	339	10	137	9	80	92	161	Rc1/8	77	64	295.1
HTF10016-7.5	16	100	89	2.5x3	II	423	1 710	145	185	32	227	10	165	11	91	109	184	Rc1/8	77	48	202.3
HTF10016-10	16	100	89	2.5x4	III	542	2 280	145	185	32	275	10	165	11	91	109	184	Rc1/8	77	48	269.8
HTF12016-7.5	16	120	109	2.5x3	II	457	2 050	173	213	32	227	10	193	11	104	126	210	Rc1/8	77	48	248.9
HTF12016-10	16	120	109	2.5x4	III	586	2 730	173	213	32	275	10	193	11	104	126	210	Rc1/8	77	48	331.9

Remarks: 1. The ball nut length with no seals is shorter by M than that of a ball nut with seals.
 2. Please consult NSK if load exceeds the allowable axial load (F_a max.).
 3. The allowable axial load (F_a max.) is determined in accordance with the mounting conditions of ball screws recommended by NSK.
 Refer to page 34 for the mounting conditions. If your mounting conditions differ from those provided, please consult NSK.

HTF Type

Outline drawing

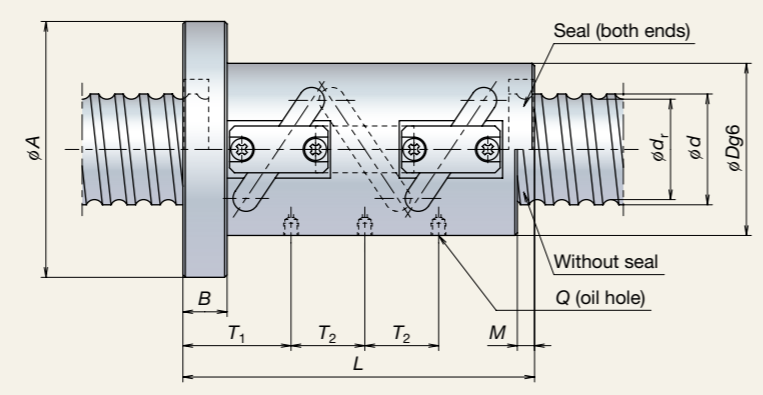
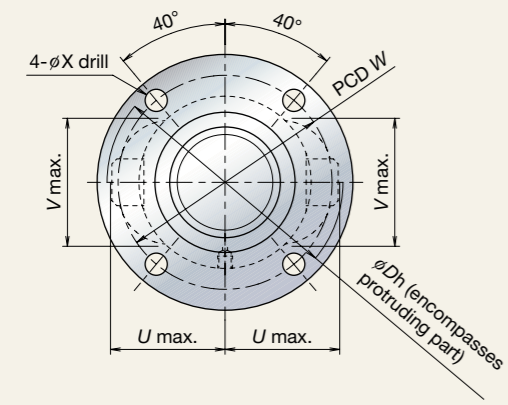

Nut model II

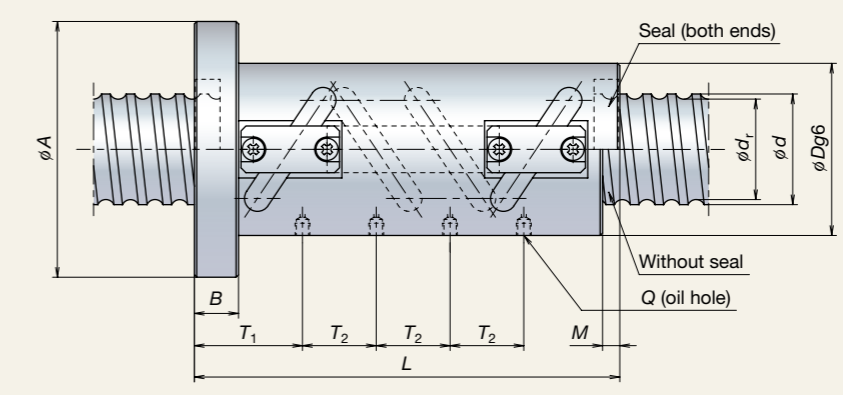

Nut model III

HTF Type Specifications

Model No.	Lead (mm) ℓ	Shaft dia. (mm) d	Root dia. (mm) d_r	Effective ball turns Turns \times Circuits	Nut model	Basic load rating (kN)		Ball nut dimensions (mm)												Allowable axial load F_a max. (kN)	
						Dynamic C_a	Static C_{0a}	D	A	B	L	M	W	X	U	V	D_h	Q	T_1		T_2
HTF6320-7.5	20	63	49	2.5×3	II	457	1 320	117	157	32	273	12	137	11	83.5	81	168	Rc1/8	88	60	147.3
HTF6320-10	20	63	49	2.5×4	III	586	1 760	117	157	32	333	12	137	11	83.5	81	168	Rc1/8	88	60	196.5
HTF6320-10.5	20	63	49	3.5×3	II	600	1 810	117	157	32	333	12	137	11	83.5	81	168	Rc1/8	88	80	205.4
HTF8020-7.5	20	80	66	2.5×3	II	511	1 690	130	170	32	273	12	150	11	89.5	96	181	Rc1/8	88	60	192.6
HTF8020-10	20	80	66	2.5×4	III	655	2 250	130	170	32	333	12	150	11	89.5	96	181	Rc1/8	88	60	256.8
HTF8020-10.5	20	80	66	3.5×3	II	670	2 300	130	170	32	333	12	150	11	89.5	96	181	Rc1/8	88	80	272.4
HTF10020-7.5	20	100	86	2.5×3	II	571	2 140	145	185	32	273	12	165	11	97.5	114	196	Rc1/8	88	60	248.6
HTF10020-10	20	100	86	2.5×4	III	731	2 850	145	185	32	333	12	165	11	97.5	114	196	Rc1/8	88	60	331.5
HTF10020-10.5	20	100	86	3.5×3	II	748	2 920	145	185	32	333	12	165	11	97.5	114	196	Rc1/8	88	80	346.1
HTF10020-14	20	100	86	3.5×4	III	958	3 890	145	185	32	413	12	165	11	97.5	114	196	Rc1/8	88	80	461.5
HTF12020-7.5	20	120	106	2.5×3	II	620	2 550	173	213	40	281	12	193	11	111	131	223	Rc1/8	96	60	304.7
HTF12020-10	20	120	106	2.5×4	III	794	3 400	173	213	40	341	12	193	11	111	131	223	Rc1/8	96	60	406.3
HTF12020-10.5	20	120	106	3.5×3	II	813	3 530	173	213	40	341	12	193	11	111	131	223	Rc1/8	96	80	424.7
HTF12020-14	20	120	106	3.5×4	III	1 040	4 710	173	213	40	421	12	193	11	111	131	223	Rc1/8	96	80	566.2
HTF14020-7.5	20	140	126	2.5×3	II	663	3 000	204	250	40	281	12	226	14	122.5	148	248	Rc1/8	96	60	360.9
HTF14020-10	20	140	126	2.5×4	III	849	4 000	204	250	40	341	12	226	14	122.5	148	248	Rc1/8	96	60	481.2

Remarks: 1. The ball nut length with no seals is shorter by M than that of a ball nut with seals.
 2. Please consult NSK if load exceeds the allowable axial load (F_a max.).
 3. The allowable axial load (F_a max.) is determined in accordance with the mounting conditions of ball screws recommended by NSK. Refer to page 34 for the mounting conditions. If your mounting conditions differ from those provided, please consult NSK.

HTF Type

Outline drawing

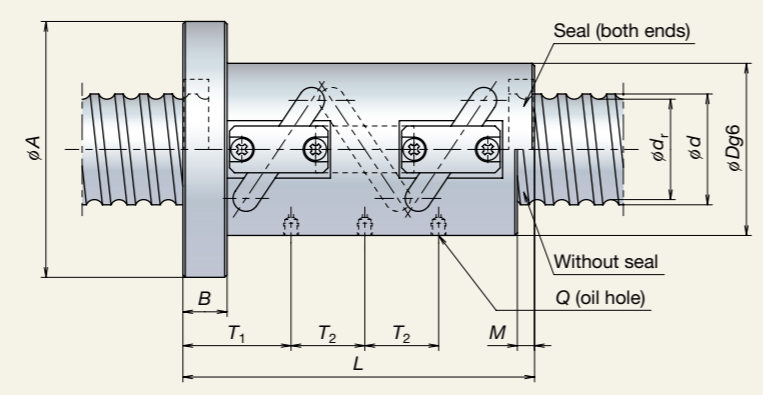
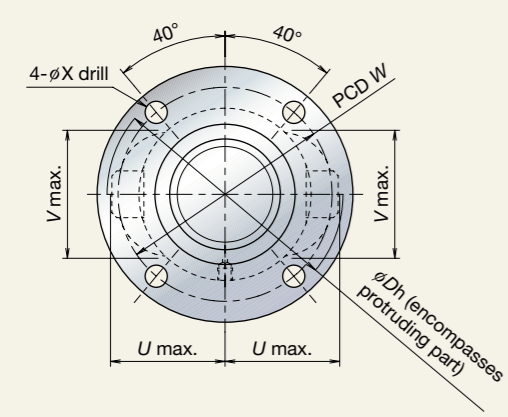

Nut model II

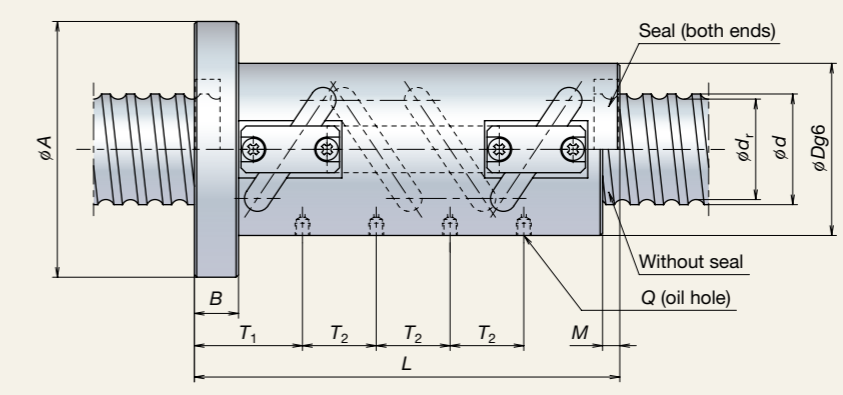

Nut model III

HTF Type Specifications

Model No.	Lead (mm) ℓ	Shaft dia. (mm) d	Root dia. (mm) d_r	Effective ball turns Turns × Circuits	Nut model	Basic load rating (kN)		Ball nut dimensions (mm)												Allowable axial load F_a max. (kN)	
						Dynamic C_a	Static C_{0a}	D	A	B	L	M	W	X	U	V	D_h	Q	T_1		T_2
HTF8025-7.5	25	80	64	2.5×3	II	663	2 020	145	185	40	338	17	165	11	102	100	206	Rc1/8	109.25	75	228.3
HTF10025-7.5	25	100	84	2.5×3	II	734	2 550	159	199	40	338	17	179	11	108.5	118	219	Rc1/8	109.25	75	293.2
HTF10025-10	25	100	84	2.5×4	III	940	3 400	159	199	40	413	17	179	11	108.5	118	219	Rc1/8	109.25	75	391.0
HTF10025-10.5	25	100	84	3.5×3	II	962	3 490	159	199	40	413	17	179	11	108.5	118	219	Rc1/8	109.25	100	409.1
HTF10025-14	25	100	84	3.5×4	III	1 230	4 650	159	199	40	513	17	179	11	108.5	118	219	Rc1/8	109.25	100	545.5
HTF12025-7.5	25	120	104	2.5×3	II	792	3 080	173	213	40	338	17	193	11	116	135	233	Rc1/8	109.25	75	358.2
HTF12025-10	25	120	104	2.5×4	III	1 010	4 110	173	213	40	413	17	193	11	116	135	223	Rc1/8	109.25	75	477.6
HTF12025-10.5	25	120	104	3.5×3	II	1 040	4 200	173	213	40	413	17	193	11	116	135	233	Rc1/8	109.25	100	505.7
HTF12025-14	25	120	104	3.5×4	III	1 330	5 600	173	213	40	513	17	193	11	116	135	223	Rc1/8	109.25	100	674.2
HTF14025-7.5	25	140	124	2.5×3	II	842	3 610	204	250	40	338	17	226	14	127.5	153	258	Rc1/8	109.25	75	423.1
HTF14025-10	25	140	124	2.5×4	III	1 080	4 810	204	250	40	413	17	226	14	127.5	153	258	Rc1/8	109.25	75	564.1
HTF14025-10.5	25	140	124	3.5×3	II	1 100	4 910	204	250	40	413	17	226	14	127.5	153	258	Rc1/8	109.25	100	595.2
HTF14025-14	25	140	124	3.5×4	III	1 410	6 540	204	250	40	513	17	226	14	127.5	153	258	Rc1/8	109.25	100	793.6
HTF16025-7.5	25	160	144	2.5×3	II	909	4 140	234	280	40	338	17	256	14	138	173	279	Rc1/8	109.25	75	495.3
HTF16025-10	25	160	144	2.5×4	III	1 160	5 520	234	280	40	413	17	256	14	138	173	279	Rc1/8	109.25	75	660.4

Remarks: 1. The ball nut length with no seals is shorter by M than that of a ball nut with seals.
 2. Please consult NSK if load exceeds the allowable axial load (F_a max.).
 3. The allowable axial load (F_a max.) is determined in accordance with the mounting conditions of ball screws recommended by NSK. Refer to page 34 for the mounting conditions. If your mounting conditions differ from those provided, please consult NSK.

HTF Type

Outline drawing

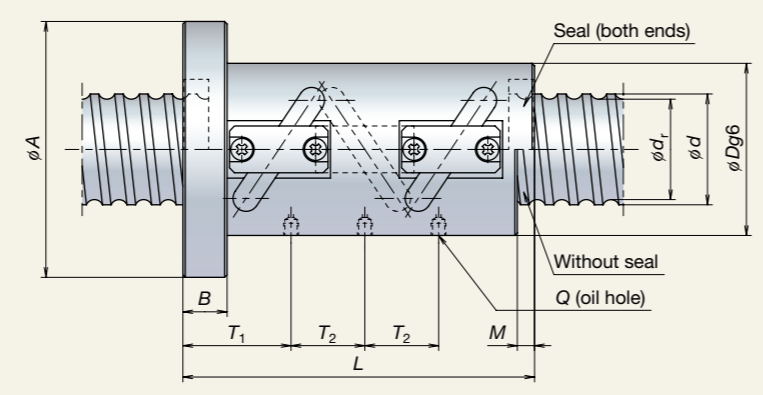
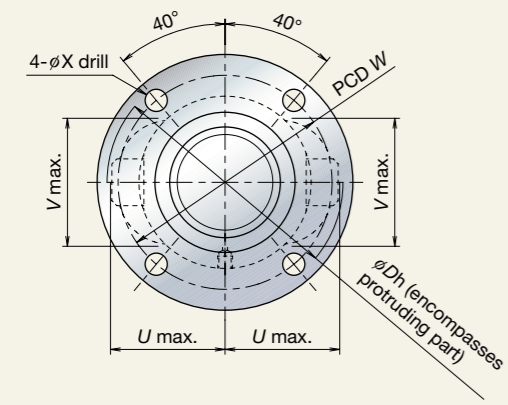

Nut model II

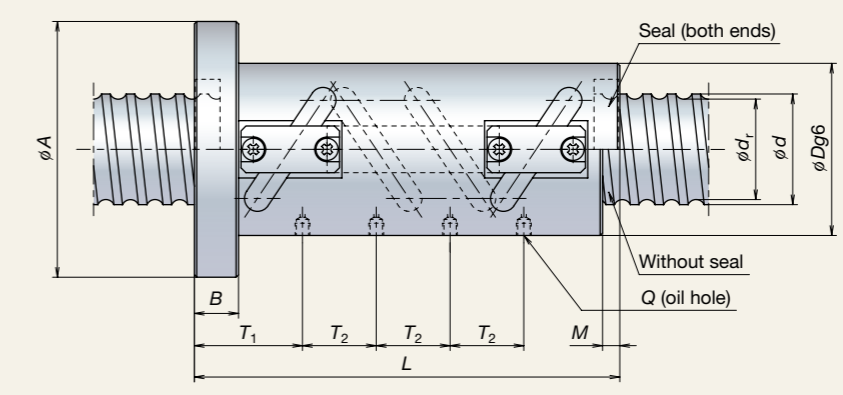

Nut model III

HTF Type Specifications

Model No.	Lead (mm) ℓ	Shaft dia. (mm) d	Root dia. (mm) d_r	Effective ball turns Turns \times Circuits	Nut model	Basic load rating (kN)		Ball nut dimensions (mm)												Allowable axial load F_a max. (kN)	
						Dynamic C_a	Static C_{0a}	D	A	B	L	M	W	X	U	V	D_h	Q	T_1		T_2
HTF14030-7.5	30	140	121	2.5×3	II	1 050	4 110	222	282	50	411	22	252	18	139	160	281	Rc1/8	134.5	90	487.1
HTF14030-10	30	140	121	2.5×4	III	1 340	5 490	222	282	50	501	22	252	18	139	160	281	Rc1/8	134.5	90	649.5
HTF14030-10.5	30	140	121	3.5×3	II	1 370	5 710	222	282	50	501	22	252	18	139	160	281	Rc1/8	134.5	120	678.2
HTF16030-7.5	30	160	141	2.5×3	II	1 120	4 760	234	294	50	411	22	264	18	148	177	299	Rc1/8	134.5	90	564.3
HTF16030-10	30	160	141	2.5×4	III	1 430	6 340	234	294	50	501	22	264	18	148	177	299	Rc1/8	134.5	90	752.4
HTF16030-10.5	30	160	141	3.5×3	II	1 460	6 520	234	294	50	501	22	264	18	148	177	299	Rc1/8	134.5	120	788.1
HTF20030-7.5	30	200	181	2.5×3	II	1 240	5 960	290	350	50	411	22	320	18	178	212	359	Rc1/8	134.5	90	718.8
HTF20030-10	30	200	181	2.5×4	III	1 590	7 950	290	350	50	501	22	320	18	178	212	359	Rc1/8	134.5	90	958.4
HTF14032-7.5	32	140	118	2.5×3	II	1 270	4 740	222	296	70	465	22	259	22	148	163	299	Rc1/8	166.5	96	549.3
HTF14032-10	32	140	118	2.5×4	III	1 630	6 320	222	296	70	561	22	259	22	148	163	299	Rc1/8	166.5	96	732.5
HTF14032-10.5	32	140	118	3.5×3	II	1 670	6 420	222	296	70	561	22	259	22	148	163	299	Rc1/8	166.5	128	756.9
HTF16032-7.5	32	160	138	2.5×3	II	1 330	5 370	234	308	70	465	22	271	22	152	181	307	Rc1/8	166.5	96	636.0
HTF16032-10	32	160	138	2.5×4	III	1 700	7 160	234	308	70	561	22	271	22	152	181	307	Rc1/8	166.5	96	848.1
HTF16032-10.5	32	160	138	3.5×3	II	1 750	7 460	234	308	70	561	22	271	22	152	181	307	Rc1/8	166.5	128	885.5
HTF20032-7.5	32	200	178	2.5×3	II	1 470	6 840	290	364	70	465	22	327	22	182	215	367	Rc1/8	166.5	96	809.4
HTF20032-10	32	200	178	2.5×4	III	1 890	9 120	290	364	70	561	22	327	22	182	215	367	Rc1/8	166.5	96	1 079.2

Remarks: 1. The ball nut length with no seals is shorter by M than that of a ball nut with seals.
 2. Please consult NSK if load exceeds the allowable axial load (F_a max.).
 3. The allowable axial load (F_a max.) is determined in accordance with the mounting conditions of ball screws recommended by NSK.
 Refer to page 34 for the mounting conditions. If your mounting conditions differ from those provided, please consult NSK.

HTF-ASRC Type and HTF-ASRD Type Equipped with Grease Retaining A1 Seal

1 Specifications

Equipped with grease retaining A1 seal

The optimum design of the A1 seal (patent applied for and pending) allows superior grease retaining performance.

Recirculation system: Equipped with SRC or end deflector

These ball screws are used with the SRC or the end deflector recirculation system, which pick up balls smoothly in the direction they are moving.

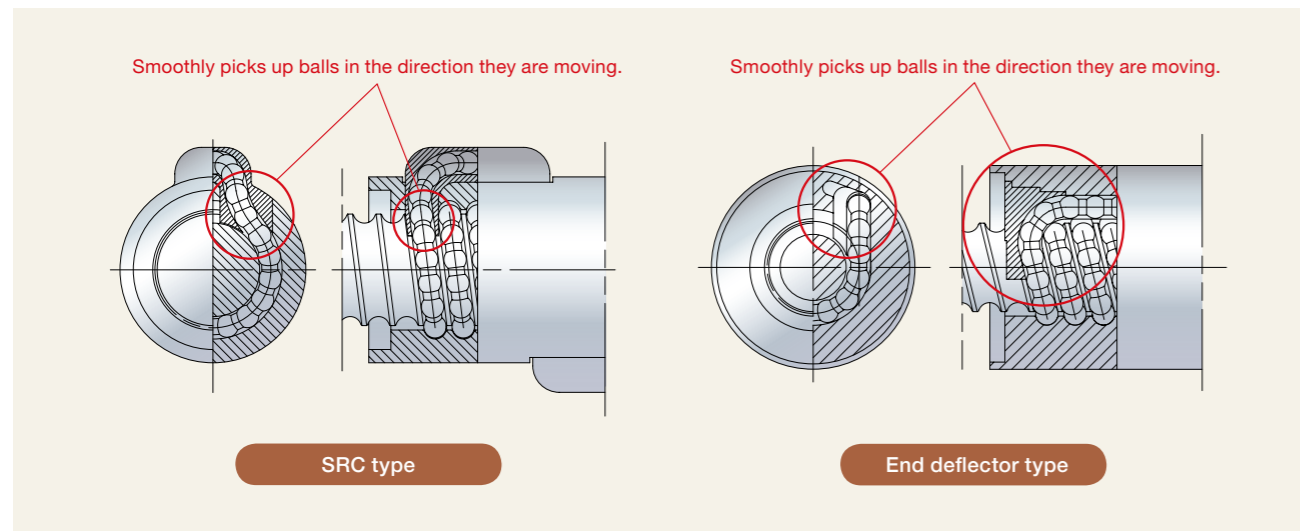

Allowable d-n value and feed speed

Lead 16 mm: 160 000 or less
 Lead 20 and 25 mm: 140 000 or less
 Lead 32, 40 and 50 mm: 120 000 or less
 d-n: Shaft diameter d (mm) × Rotational speed (min⁻¹)

Allowable feed speed of combinations of shaft diameter and lead

Unit: mm/s

Shaft dia. (mm)	Lead (mm)	HTF-ASRC type			HTF-ASRD type		
		16	20	25	32	40	50
50		860	—	—	—	1 600	—
63		680	740	930	1 000	1 250	—
80		540	590	730	—	—	1 250
100		—	470	590	—	—	—
120		—	390	490	—	—	—

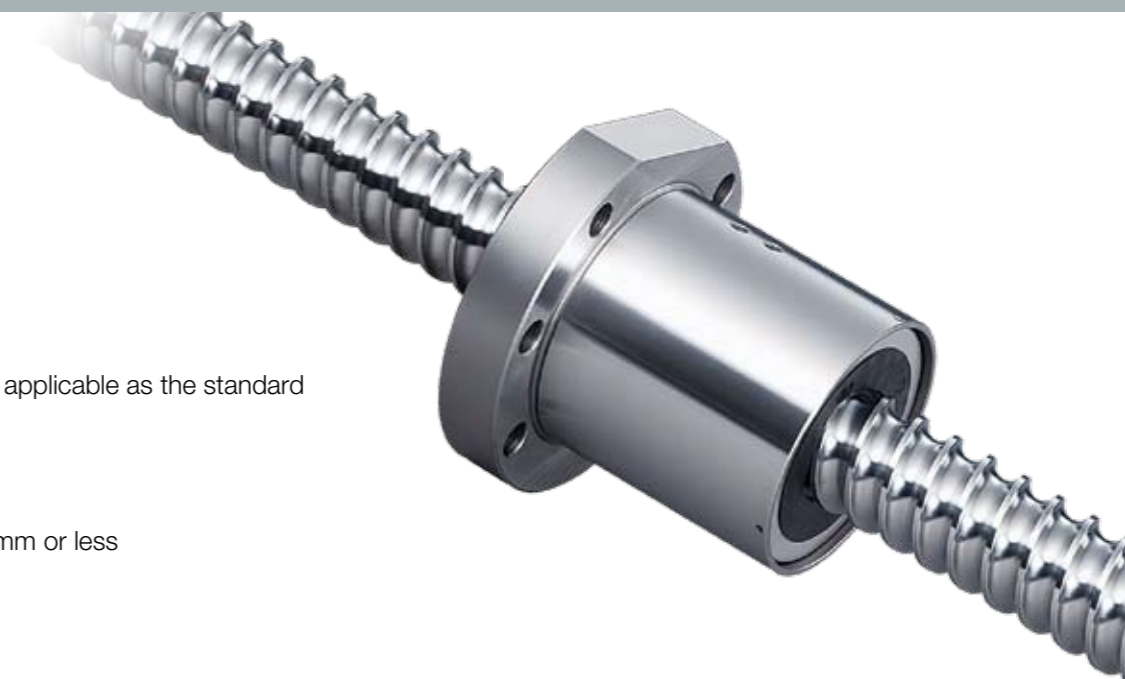

Accuracy grade

Ct7 of JIS B 1192 (1997) is applicable as the standard accuracy grade.

Axial play

Standard axial play: 0.050 mm or less

2 Design Precautions

- When designing the shaft ends, one end of the screw shaft must meet one of the following conditions. If not, we cannot install the ball nut on the screw shaft.
 - Cut the ball groove through to the shaft end.
 - The diameters of bearing journals and the gear or pulley seat must be less than the root diameter of ball groove "dr" specified on the dimension table.
- The table below shows the maximum length of screw shaft for the equipment of the A1 seal.
- Please contact NSK with your special design requirements.

Unit: mm

Shaft dia.	Max. shaft length
50	850
63	950
80	1 100
100, 120	1 300

3 Selection of Ball Screw

- Please refer to pages 33 and 34 for details on the operating life of the ball screw and instructions on installation and lubrication.
- Please consult NSK in the case of a short stroke operation less than or equal to four times the length of the ball screw lead.

4 Environmental Conditions

- Maximum operating temperature: 70°C (at outside diameter of ball nut)
- Never use in an environment where degreasing solvents are present.
 Examples: white kerosine, rust preventive oil (containing white kerosine)

HTF-ASRC Type

Outline drawing

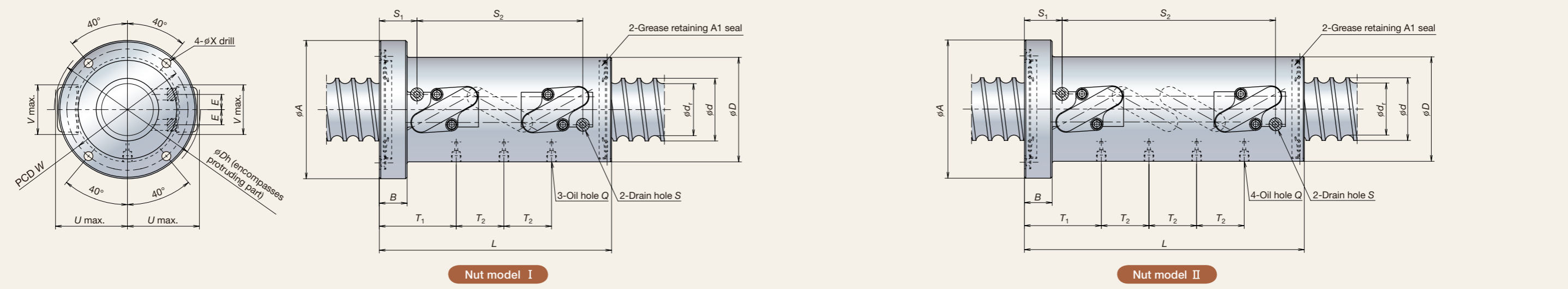

HTF-ASRC Type Specifications

Model No.	Lead (mm) ℓ	Shaft dia. (mm) d	Root dia. (mm) d_r	Effective ball turns Turns \times Circuits	Nut model	Basic load rating (kN)		Ball nut dimensions (mm)														Allowable axial load F_a max. (kN)		
						Dynamic C_a	Static C_{0a}	D	A	B	L	W	X	U	V	Dh	Q	T_1	T_2	S	E		S_1	S_2
HTF-ASRC5016-7.5	16	50	39	2.5x3	I	306	818	95	129	28	234	112	9	66	50	134	Rc1/8	77.5	48	Rc1/4	15.3	38	167	91.1
HTF-ASRC6316-7.5	16	63	52	2.5x3	I	343	1 050	105	139	28	234	122	9	72.5	50	148	Rc1/8	77.5	48	Rc1/4	15.3	38	167	119.7
HTF-ASRC6316-10	16	63	52	2.5x4	II	439	1 410	105	139	28	282	122	9	72.5	50	148	Rc1/8	77.5	48	Rc1/4	15.3	38	215	159.6
HTF-ASRC6316-10.5	16	63	52	3.5x3	I	450	1 450	105	139	28	282	122	9	72.5	50	148	Rc1/8	77.5	64	Rc1/4	11.8	38	215	167.6
HTF-ASRC6316-14	16	63	52	3.5x4	II	576	1 930	105	139	28	346	122	9	72.5	50	148	Rc1/8	77.5	64	Rc1/4	11.8	38	279	215.0
HTF-ASRC8016-10.5	16	80	69	3.5x3	I	501	1 870	120	154	32	284	137	9	80	60	165	Rc1/8	81.5	64	Rc1/4	11.3	42	215	221.3
HTF-ASRC8016-14	16	80	69	3.5x4	II	642	2 490	120	154	32	348	137	9	80	60	165	Rc1/8	81.5	64	Rc1/4	11.3	42	279	295.1
HTF-ASRC6320-7.5	20	63	49	2.5x3	I	457	1 280	117	157	32	279	137	11	80	62	163	Rc1/8	90	60	Rc1/4	18.5	43	204	147.1
HTF-ASRC6320-10	20	63	49	2.5x4	II	586	1 710	117	157	32	339	137	11	80	62	163	Rc1/8	90	60	Rc1/4	18.5	43	264	196.1
HTF-ASRC8020-10.5	20	80	66	3.5x3	I	671	2 300	130	170	32	339	150	11	88	64	180	Rc1/8	90	80	Rc1/4	15	43	264	267.4
HTF-ASRC10020-10.5	20	100	86	3.5x3	I	749	2 910	145	185	32	339	165	11	97	78	199	Rc1/8	90	80	Rc1/4	13	43	264	345.9
HTF-ASRC10020-14	20	100	86	3.5x4	II	959	3 890	145	185	32	419	165	11	97	78	199	Rc1/8	90	80	Rc1/4	13	43	344	461.2
HTF-ASRC12020-7.5	20	120	106	2.5x3	I	621	2 550	173	213	40	287	193	11	109.5	88	229	Rc1/8	98	60	Rc1/4	20	51	204	304.6
HTF-ASRC12020-10	20	120	106	2.5x4	II	795	3 400	173	213	40	347	193	11	109.5	88	229	Rc1/8	98	60	Rc1/4	20	51	264	406.1
HTF-ASRC6325-10.5	25	63	49	3.5x3	I	600	1 770	117	157	32	405	137	11	81.5	61	167	Rc1/8	101.75	100	Rc1/4	13.5	47	323	170.0
HTF-ASRC8025-7.5	25	80	63	2.5x3	I	632	1 960	145	185	40	347	165	11	99.5	73	202	Rc1/8	111.75	75	Rc1/4	19	55	251	221.1
HTF-ASRC10025-10.5	25	100	83	3.5x3	I	964	3 430	159	199	40	422	179	11	108	79	220	Rc1/8	111.75	100	Rc1/4	14	55	326	408.4
HTF-ASRC10025-14	25	100	83	3.5x4	II	1 230	4 580	159	199	40	522	179	11	108	79	220	Rc1/8	111.75	100	Rc1/4	14	55	426	544.6
HTF-ASRC12025-10.5	25	120	103	3.5x3	I	1 040	4 200	173	213	40	421	193	11	116	92	238	Rc1/8	111.25	100	Rc1/4	11	55	325	498.0
HTF-ASRC12025-14	25	120	103	3.5x4	II	1 330	5 600	173	213	40	521	193	11	116	92	238	Rc1/8	111.25	100	Rc1/4	11	55	425	664.0

- Remarks: 1. Drain holes are plugged during shipping.
 2. The right hand screw is the standard. For specifications on left hand screws, contact NSK.
 3. The allowable axial load (F_a max.) is determined in accordance with the mounting conditions of ball screws recommended by NSK. Refer to page 34 for the mounting conditions. If your mounting conditions differ from those provided, please consult NSK.
 4. Connect a grease drain pipe to drain hole S before use of the ball screw.

HTF-ASRD Type

Outline drawing

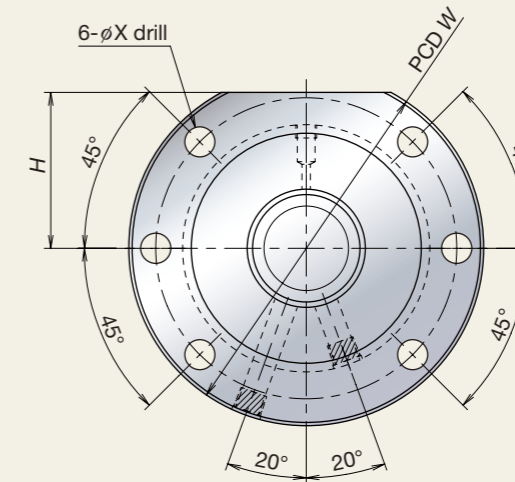
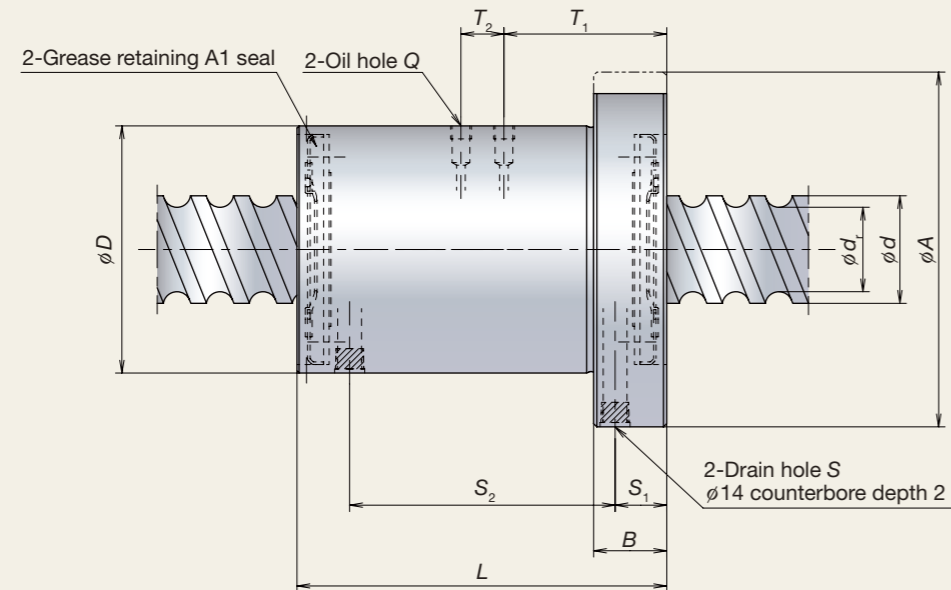

HTF-ASRD Type Specifications

Model No.	Lead (mm) ℓ	Shaft dia. (mm) d	Root dia. (mm) d_r	Basic load rating (kN)		Ball nut dimensions (mm)													Allowable axial load F_a max. (kN)
				Dynamic C_a	Static C_{0a}	D	A	B	L	H	W	X	Q	T_1	T_2	S	S_1	S_2	
HTF-ASRD6332-4E	32	63	49	233	590	140	190	36	186	85	165	14	Rc1/8	85.1	—	Rc1/4	23.5	138	72.6
HTF-ASRD5040-6E	40	50	39	195	491	115	165	34	172	72.5	140	14	Rc1/8	75.7	20	Rc1/4	24	123.5	67.6
HTF-ASRD5040-8E	40	50	39	255	679	115	165	34	212	72.5	140	14	Rc1/8	95.7	20	Rc1/4	24	163.5	92.0
HTF-ASRD6340-6E	40	63	49	291	768	140	200	36	176	90	170	18	Rc1/8	77.6	20	Rc1/4	24	127.5	106.3
HTF-ASRD6340-8E	40	63	49	381	1 060	140	200	36	216	90	170	18	Rc1/8	97.6	20	Rc1/4	24	167.5	144.7
HTF-ASRD8050-6E	50	80	63	401	1 180	175	250	40	208	110	210	22	Rc1/8	91.1	25	Rc1/4	26	156	163.7
HTF-ASRD8050-8E	50	80	63	526	1 630	175	250	40	258	110	210	22	Rc1/8	116.1	25	Rc1/4	26	206	224.1

Remarks: 1. Drain holes are plugged during shipping.

2. The right hand screw is the standard. For specifications on left hand screws, contact NSK.

3. The allowable axial load (F_a max.) is determined in accordance with the mounting conditions of ball screws recommended by NSK.

Refer to page 34 for the mounting conditions. If your mounting conditions differ from those provided, please consult NSK.

4. Connect a grease drain pipe to drain hole S before use of the ball screw.

Technical Description

1 Examples of Application

Application	Injection molding machine	Die cast machine	Servo press	Press brake	Punch press	Powder press	Bending machine	Press fitting machine	Elevating machine
Return tube type	○	○	○	○	○	○	○	○	○
SRC type	◎	○	◎	◎	○	◎	◎	◎	○
End deflector type	◎	◎			○				○

◎ = Excellent, ○ = Good

2 Shaft End Configuration

A variety of shaft end configurations are available for high torque transmission.

Examples of supported forms

- Involute splines (JIS B 1603)
- Straight-sided splines (JIS B 1601)
- Keyways

3 Low Noise

With the new ball recirculation system, SRC and end deflector types achieve a noise reduction of 6-10 dB(A) compared with the tube type.

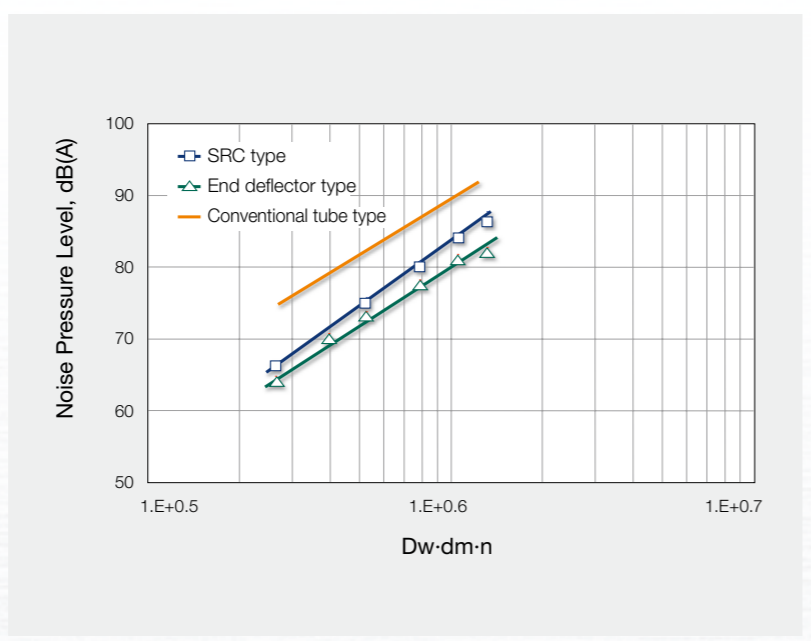

4 Resin Retaining Piece NSK S1™

A moment load caused by misalignment of a ball screw can hinder smooth motion of the balls, thus causing ball jamming in the ball recirculation circuits and adversely affecting the durability of the ball screw. By incorporating the resin retaining piece NSK S1™ between balls, NSK has greatly improved the durability of ball screws under a moment load.

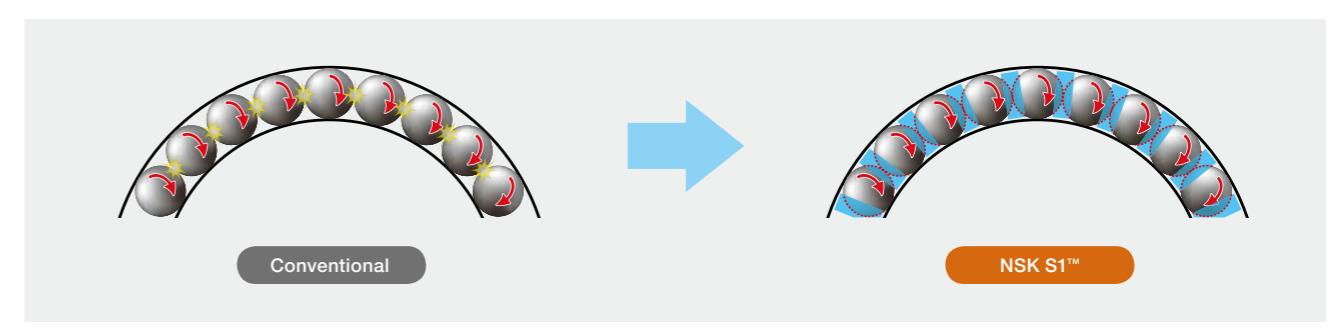

Durability test with continuous high load

Test model: HTF10025-7.5
All load balls (without S1), and with S1

Test conditions:
Load condition: Forward 200 kN, Back 20 kN
Stroke: 70 mm, Cycle time: 9 sec
Lubrication: Grease
Temperature: Normal

Mounting error: Max. 0.03 mm

Outer surface of balls

All load balls: very good (after 100 000 cycles)

0.3 mm

All load balls: damaged (after 10 000 cycles)

0.3 mm

With S1: very good (after 100 000 cycles)

Technical Description

5 Even Load Distribution Technology in Ball Nut

Japan patents: 3675129, 3714026, 3714015, & 4144610

Theory of even load distribution 1 (applies to SRC and return tube types)

Ball return tubes are located 180 degrees apart for equal load distribution to the balls.

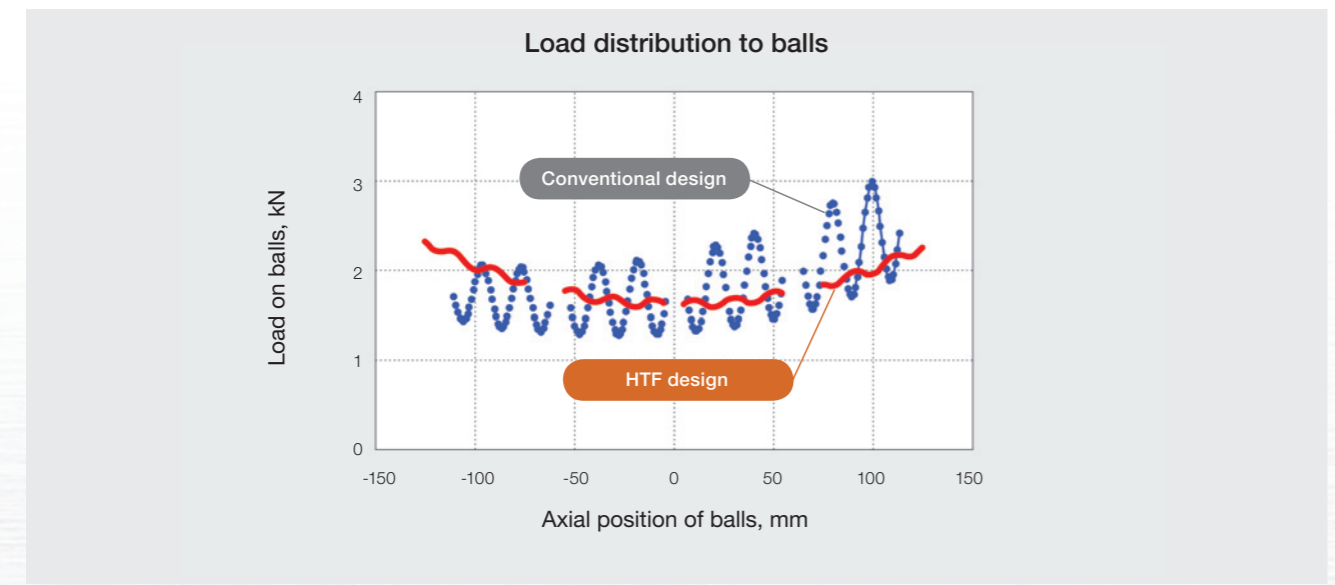
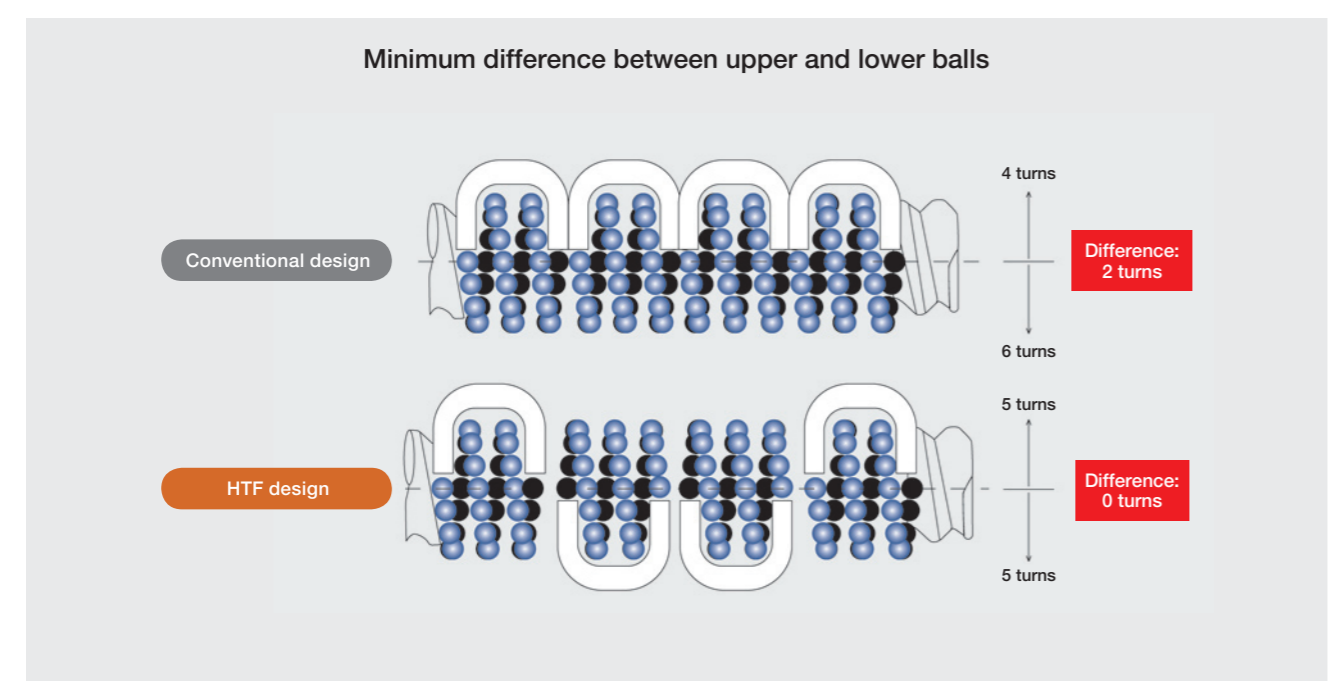

Theory of even load distribution 2 (applies to SRC and return tube types)

Layout of ball return tubes is symmetrically designed in axial direction to be effective for moment balance.

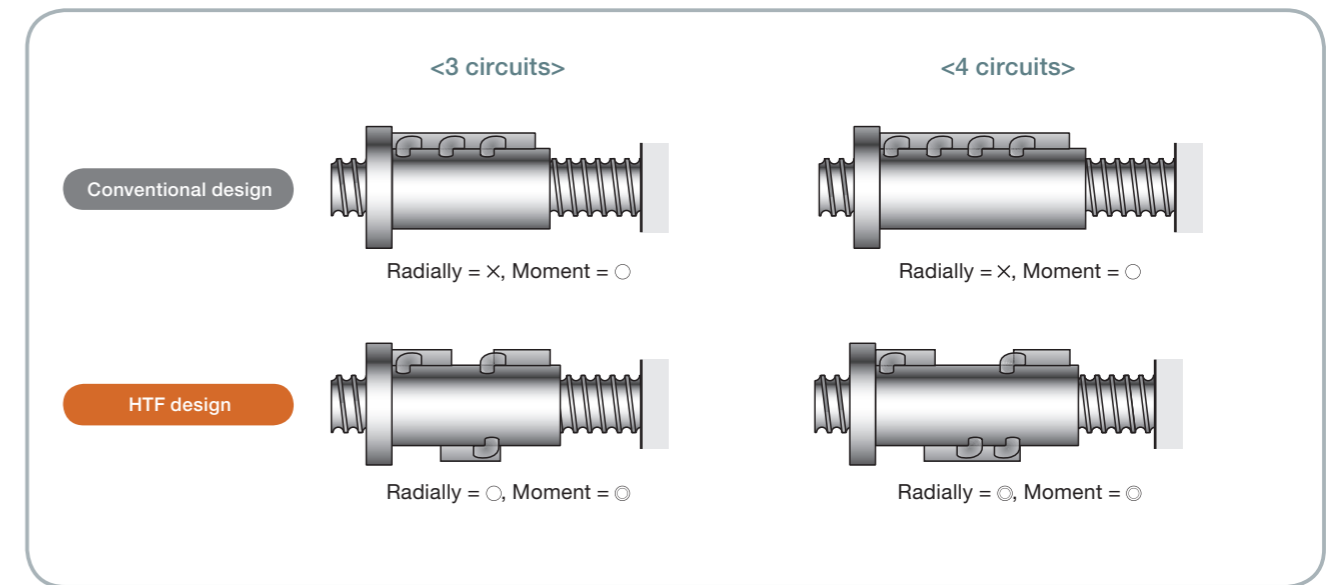

Theory of even load distribution 3 (applies to all series)

Acting point of load is to be at opposite ends of screw shaft and ball nut, shown below as case (A), in order to balance the axial deformation.

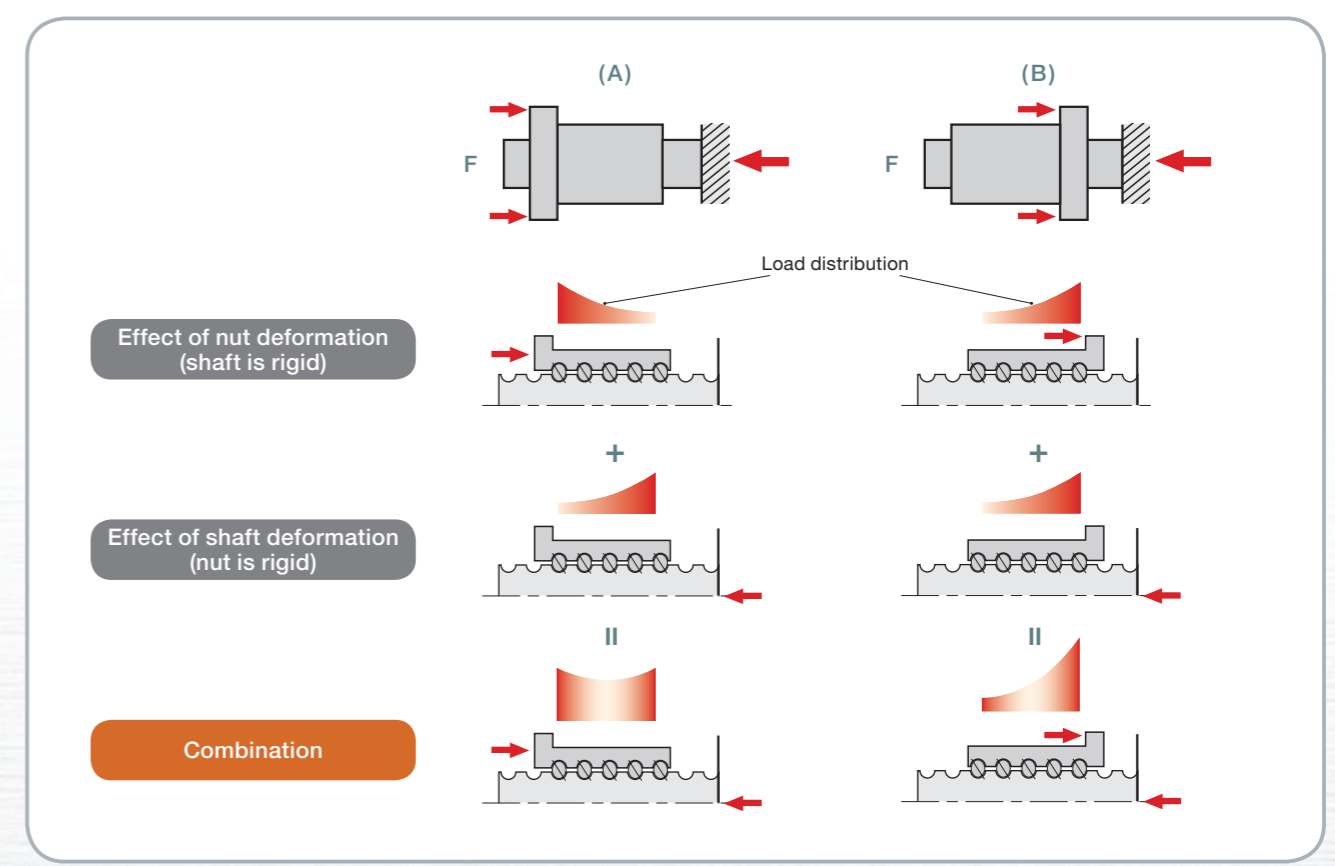

Technical Description

6 Life of Ball Screw

Computational life, which is estimated by calculation, is the flaking life caused by rolling contact fatigue. The fatigue life of a ball screw can be estimated by basic dynamic load rating (C_a).

Basic dynamic load rating (C_a)

Basic dynamic load rating (C_a) is the axial load that allows 90% of a group of the same ball screws to rotate one million times (10^6 rev) under the same conditions without flaking occurring due to rolling contact fatigue. Basic dynamic load ratings (C_a) are shown in the dimension tables.

How to calculate fatigue life

The fatigue life of a ball screw is obtained by the following formula.

$$L = \left(\frac{C_a}{F_a \cdot f_w} \right)^3 \cdot 10^6$$

L : Rated fatigue life (rev)

L_t : Life in hours (h)

L_s : Life by running distance (km)

C_a : Basic dynamic load rating (N)

F_a : Axial load (N)

n : Rotational speed (min^{-1})

l : Lead (mm)

f_w : Load factor*

$$L_t = \frac{L}{60n}$$

$$L_s = \frac{L \cdot l}{10^6}$$

*The load factor is decided by operating conditions. Consult NSK when impact and/or vibrations occur during the operation.

Mounting of ball screw

NSK ball screws for high-load drive achieve high capacity by “special internal design exclusively for high-load use” and “the theory of even load distribution.”

To maximize these benefits, it is recommended to mount the ball screw as shown below.

Do not apply external tension force to the bolts. If bolts receive tension force, the strength of bolts must be checked.

Recommended mounting direction

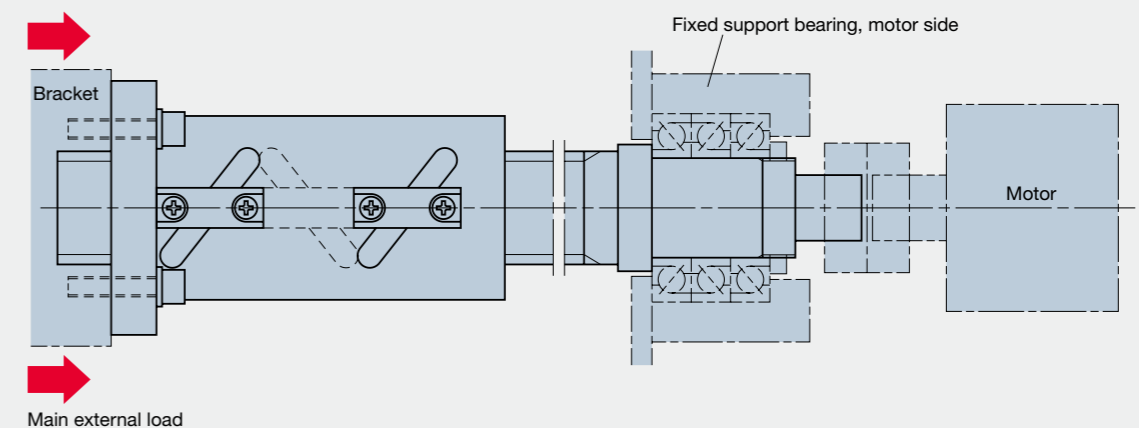

Precautions for lubrication use

When using the ball screw, it is necessary to supply lubrication.

Even if the grease is of high quality, it gradually deteriorates and its lubrication function diminishes in relation to the period of use.

Also, the grease in the ball nut is gradually removed by stroke movement. In some environments, the grease becomes dirty, and foreign objects may enter.

Grease should be replenished periodically.

(For a high-load application, we recommend the use of a high-load grease with an extreme pressure additive.)

Technical Description

7 Grease Retaining A1 Seal

Greatly improved grease retaining performance

Thanks to the special ball groove profile of the screw shaft together with the grease retaining A1 seal, the grease retaining characteristics have greatly improved compared with those of existing plastic seals.

Grease leakage at initial cycle operation
(Test piece: HTF-ASRC6316-10.5 with high-load grease with an extreme pressure additive [worked penetration: 300])

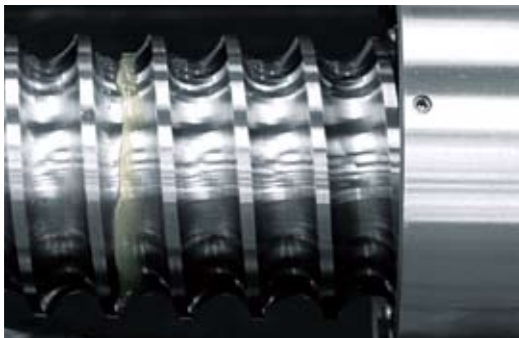

With grease retaining A1 seals

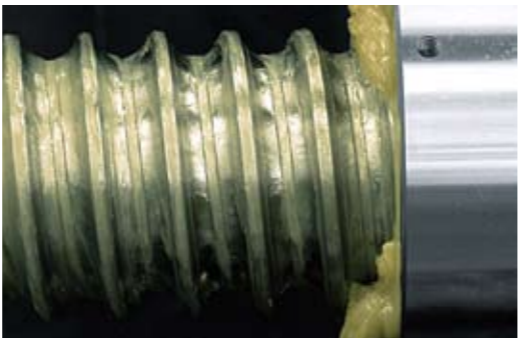

With conventional labyrinth seals

Suppresses grease scattering and preserves a clean environment

Use of the A1 seal greatly suppresses grease scattering, showing a significant improvement over the use of existing plastic seals. The A1 seal simplifies the design of your cover, helping to preserve a clean and healthy environment.

Grease splash after 100-cycle operation

Test conditions	Test piece	Speed	Stroke	Lubrication
	HTF-ASRC6316-10.5	1 600 min ⁻¹	500 mm	High-load grease with an extreme pressure additive

After initial run of 100 cycles at 200 min⁻¹, grease was wiped off from shaft OD, then photos were taken at the speed of 1 600 min⁻¹.



With grease retaining A1 seals
(stroke center area)



With existing plastic seals
(stroke center area)

Low friction torque and low-heat generation

The increase of dynamic torque caused by the A1 seal is very small (30 to 50 Ncm in case of ball screw with 80-mm diameter). This level of increase has practically no impact on the driving torque. The practical temperature rise caused by the A1 seal is merely 2 to 3°C higher than that of existing plastic seals.

Construction of ball screw equipped with grease retaining A1 seal

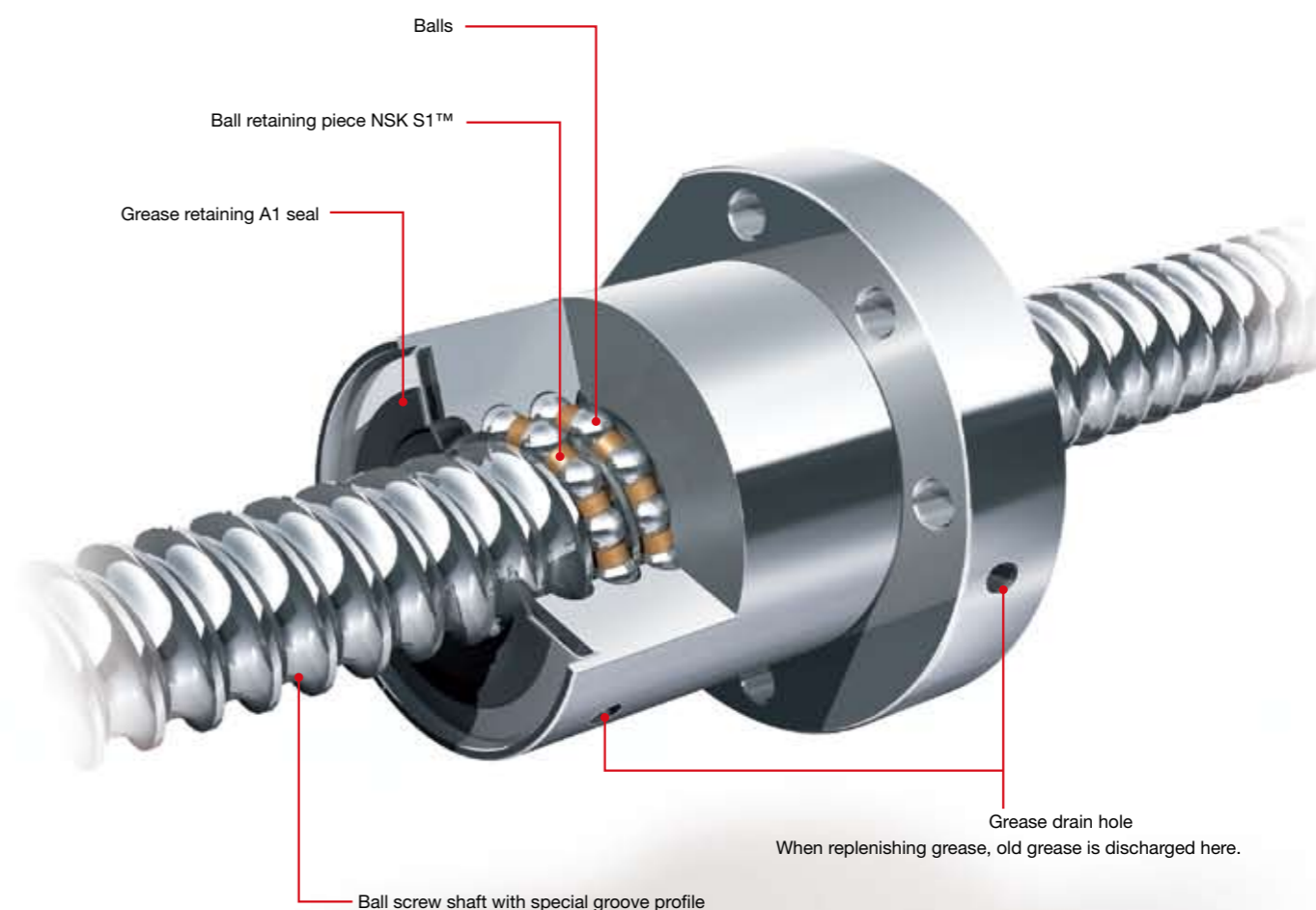

Technical Data sheet

NSK Technical Data Sheet for NSK High-Load Drive Ball Screw

Custom-made ball screw

Company name:	Date:	NSK sales office
Section:	Person in charge:	
Address:		

Name of machine*1: Electric injection molding machine; 30-ton capacity Application*2: Clamping axis

Drawing/rough sketch attached?: Yes No

*1 Please specify capacity of the machine in case of injection molding machine or press.
*2 If the application is injection molding machine, please indicate the axis. (Examples: injection axis and clamping axis)

1. Use conditions

Operating conditions	<input checked="" type="checkbox"/> Shaft rotation-Moving nut <input type="checkbox"/> Shaft rotation-Moving shaft <input type="checkbox"/> Nut rotation-Moving nut <input type="checkbox"/> Nut rotation-Moving shaft	<input checked="" type="checkbox"/> Normal operation <input type="checkbox"/> Back drive operation <input type="checkbox"/> Oscillation	Degree of vibration / impact	<input type="checkbox"/> Smooth operation without impact <input checked="" type="checkbox"/> Normal operation <input type="checkbox"/> Operation associated with impact or vibration
Direction of load ³	<input type="checkbox"/> C-C <input checked="" type="checkbox"/> T-T <input type="checkbox"/> T-C <input type="checkbox"/> C-T <input type="checkbox"/> other (Refer to figures below.)	Mounting orientation	<input checked="" type="checkbox"/> Horizontal <input type="checkbox"/> Vertical (Indicate the direction of gravity.)	
Lubricant	<input checked="" type="checkbox"/> Grease (Brand name: <u>High-load grease with an extreme pressure additive</u>) <input type="checkbox"/> Oil (Maker:)	How to replenish lubricant	<input checked="" type="checkbox"/> Grease gun <input type="checkbox"/> Automatic (cm ³ / cycles)	
Request for oil hole	<input checked="" type="checkbox"/> NSK recommended <input type="checkbox"/> Your request			
Necessity of seals	<input checked="" type="checkbox"/> Yes <input type="checkbox"/> No	NSK S1 necessary?	<input checked="" type="checkbox"/> NSK recommended <input type="checkbox"/> Not necessary	
Environment	Temperature (<u>40</u> deg)	Particles / <input type="checkbox"/> Yes (Size of particle: a) to 0.1, b) over 0.1 to 0.3, c) over 0.3, d) Ingredient:) <input checked="" type="checkbox"/> No particle		
Surface treatment	<input checked="" type="checkbox"/> Not required <input type="checkbox"/> Low-temperature chrome plating <input type="checkbox"/> Fluoride low-temperature chrome plating <input type="checkbox"/> Other			
Quantity in mass-production	/Month	/Year	/Lot	Quantity used per machine: <u>1</u> pcs./machine

*3 Please specify loading direction code on the figures below. (Shaft fixed: |, Main load: ←)

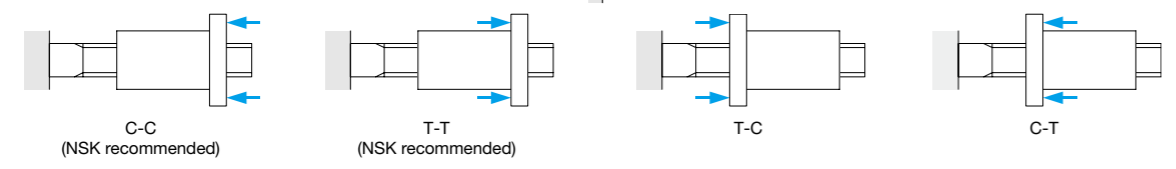

2. Specifications

Shaft diameter	φ 140 mm	Lead	32 mm	Accuracy grade	Ct7	Axial play	0.050 or less mm max.
Nut model No.	HTF 14032-7.5-S1	Effective turns of balls	2.5 × 2	Direction of turn	right	Thread length / Overall shaft length	1000 / 1500

Special note / Requests

Please calculate the life as a continuous operation based on "3. Load chart".

NSK Technical Data Sheet for NSK High-Load Drive Ball Screw

3. Load chart (If using multiple ball screws in an axis, fill out the axial load per ball screw.)

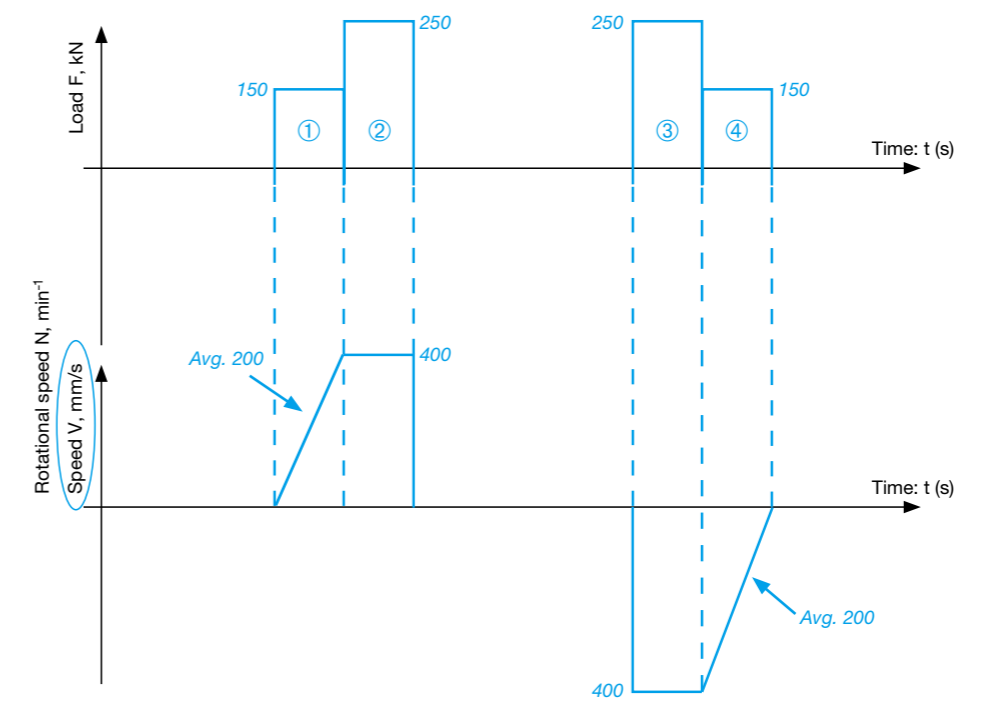

	Axial load* F (kN)	Rotational speed or Average speed		Time t (s)	Stroke St (mm)	Remarks
		N (min ⁻¹)	V (mm/s)			
①	150		200	0.5	100	
②	250		400	0.5	200	
③	250		400	0.5	200	
④	150		200	0.5	100	
⑤				Total: 2.0	Total: 600	
⑥						
⑦						
⑧						
⑨						
⑩						

Dynamic axial load (max.)*: 250 (kN) Static axial load (max.)* (at 0 mm/s): (kN)
 Stroke in normal use: 300 (mm) Maximum stroke: 500 (mm)
 Cycle time: 2.0 (s) Required life: 2500 (h or cycles)

*If using multiple ball screws in an axis, fill out the axial load per ball screw.

4. Plan to conduct the endurance test of the ball screw?

Actual data on the machine Yes N/A

Planning to check endurance (Date: From the middle of March 2008)

No (Reason:)

Endurance of the ball screw

(1) Mounting accuracy, load conditions, and lubricating conditions are the main factors affecting the ball screw fatigue life. Therefore, we recommend evaluating the influence of those factors on actual use of your machines.

(2) A temperature rise caused by operational and environmental conditions may reduce the effectiveness of lubricant.

Technical Data sheet

NSK Technical Data Sheet for NSK High-Load Drive Ball Screw

Custom-made ball screw

Company name:	Date:	NSK sales office
Section:	Person in charge:	
Address:		

Name of machine*1: _____ Application*2: _____

Drawing/rough sketch attached?: Yes No

*1 Please specify capacity of the machine in case of injection molding machine or press.

*2 If the application is injection molding machine, please indicate the axis. (Examples: injection axis and clamping axis)

1. Use conditions

Operating conditions	<input type="checkbox"/> Shaft rotation-Moving nut <input type="checkbox"/> Shaft rotation-Moving shaft <input type="checkbox"/> Nut rotation-Moving nut <input type="checkbox"/> Nut rotation-Moving shaft	<input type="checkbox"/> Normal operation <input type="checkbox"/> Back drive operation <input type="checkbox"/> Oscillation	Degree of vibration / impact	<input type="checkbox"/> Smooth operation without impact <input type="checkbox"/> Normal operation <input type="checkbox"/> Operation associated with impact or vibration	
Direction of load ³	<input type="checkbox"/> C-C <input type="checkbox"/> T-T <input type="checkbox"/> T-C <input type="checkbox"/> C-T <input type="checkbox"/> other (Refer to figures below.)	Mounting orientation	<input type="checkbox"/> Horizontal <input type="checkbox"/> Vertical (Indicate the direction of gravity.)		
Lubricant	<input type="checkbox"/> Grease (Brand name: _____) <input type="checkbox"/> Oil (Maker: _____)	How to replenish lubricant	<input type="checkbox"/> Grease gun <input type="checkbox"/> Automatic (_____ cm ³ / _____ cycles)		
Request for oil hole	<input type="checkbox"/> NSK recommended <input type="checkbox"/> Your request	Necessity of seals	<input type="checkbox"/> Yes <input type="checkbox"/> No		
Environment	Temperature (_____ deg)	NSK S1 necessary?	<input type="checkbox"/> NSK recommended <input type="checkbox"/> Not necessary		
Surface treatment	<input type="checkbox"/> Not required <input type="checkbox"/> Low-temperature chrome plating <input type="checkbox"/> Fluoride low-temperature chrome plating <input type="checkbox"/> Other				
Quantity in mass-production	/Month	/Year	/Lot	Quantity used per machine	pcs./machine

*3 Please specify loading direction code on the figures below. (Shaft fixed: |, Main load: ←→)

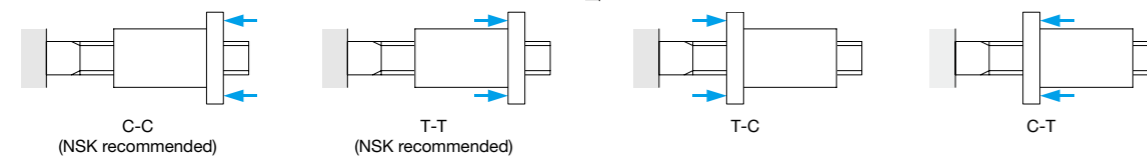

2. Specifications

Shaft diameter	φ	mm	Lead	mm	Accuracy grade		Axial play	mm max.
Nut model No.			Effective turns of balls		Direction of turn		Thread length / Overall shaft length	/

Special note / Requests

NSK Technical Data Sheet for NSK High-Load Drive Ball Screw

3. Load chart (If using multiple ball screws in an axis, fill out the axial load per ball screw.)

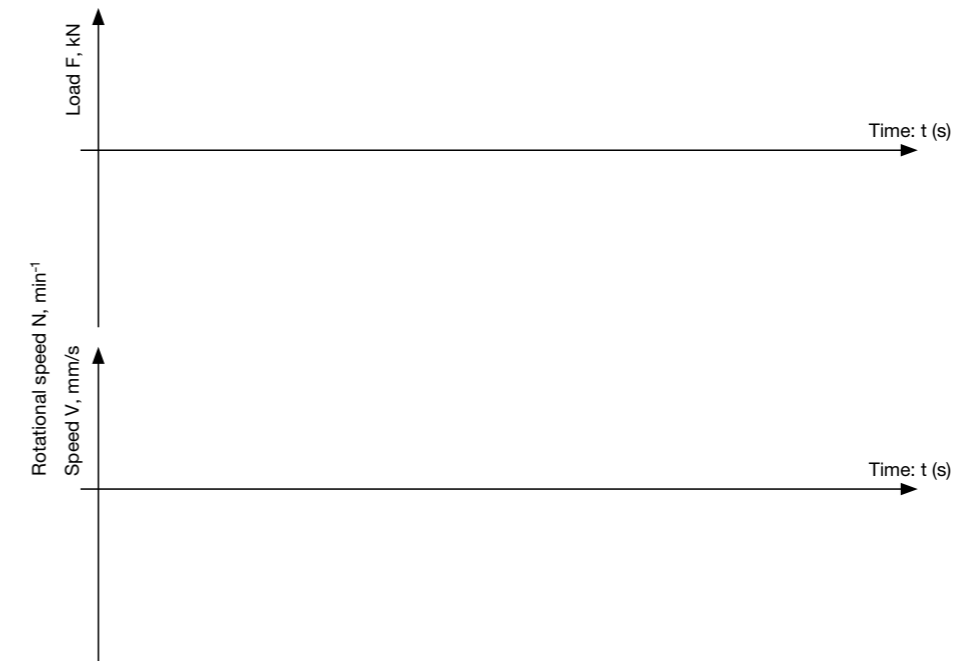

	Axial load* F (kN)	Rotational speed or Average speed N (min ⁻¹)	V (mm/s)	Time t (s)	Stroke St (mm)	Remarks
①						
②						
③						
④						
⑤						
⑥						
⑦						
⑧						
⑨						
⑩						

Dynamic axial load (max.)*: _____ (kN) Static axial load (max.)* (at 0 mm/s): _____ (kN)
 Stroke in normal use: _____ (mm) Maximum stroke: _____ (mm)
 Cycle time: _____ (s) Required life: _____ (h or cycles)

*If using multiple ball screws in an axis, fill out the axial load per ball screw.

4. Plan to conduct the endurance test of the ball screw?

Actual data on the machine Yes
 N/A Planning to check endurance (Date: _____)
 No (Reason: _____)

Endurance of the ball screw

- (1) Mounting accuracy, load conditions, and lubricating conditions are the main factors affecting the ball screw fatigue life. Therefore, we recommend evaluating the influence of those factors on actual use of your machines.
- (2) A temperature rise caused by operational and environmental conditions may reduce the effectiveness of lubricant.

TAC Series of Ball Screw Support Bearings for High-Load Applications

TAC-HR Series and TAC-SHR Series of Ball Screw Support Bearings for High-Load Applications

Angular Contact Thrust Ball Bearings of Ball Screw Support Bearings for High-Load Applications

High-capacity bearings used for supporting ball screws operating under high loads typically adopt large-diameter steel balls in order to ensure sufficient high capacity and to reduce the number of rows of combinations. With the development and commercialization of the TAC-SHR series, which has the same load rating as that of the TAC-HR series but with a smaller bore diameter, users can maintain equivalent high-capacity performance with a smaller diameter of screw shaft end without changing the number of rows. Please refer to pages 43 and 44 for applicable bearing tables.

High capacity and compact

These bearings achieve high-load capacity in a small-envelope design.

Improved reliability

These bearings offer a fivefold longer service life than that of angular contact ball bearings of the same size.

Easy handling

These bearings come in an easy-to-use universal arrangement that provides the necessary preload by simply mounting them. Procedures associated with designing and processing parts in order to adjust the preload have been eliminated.

Optimum design for reduced torque

These bearings have been optimally designed to achieve significant reductions in torque.



TAC-SHR series

The TAC-SHR series has the same outer diameter and width dimensions as the TAC-HR series but with a smaller bore diameter. Since the TAC-SHR series has the same load rating as the TAC-HR series, users can use a smaller diameter of screw shaft end.

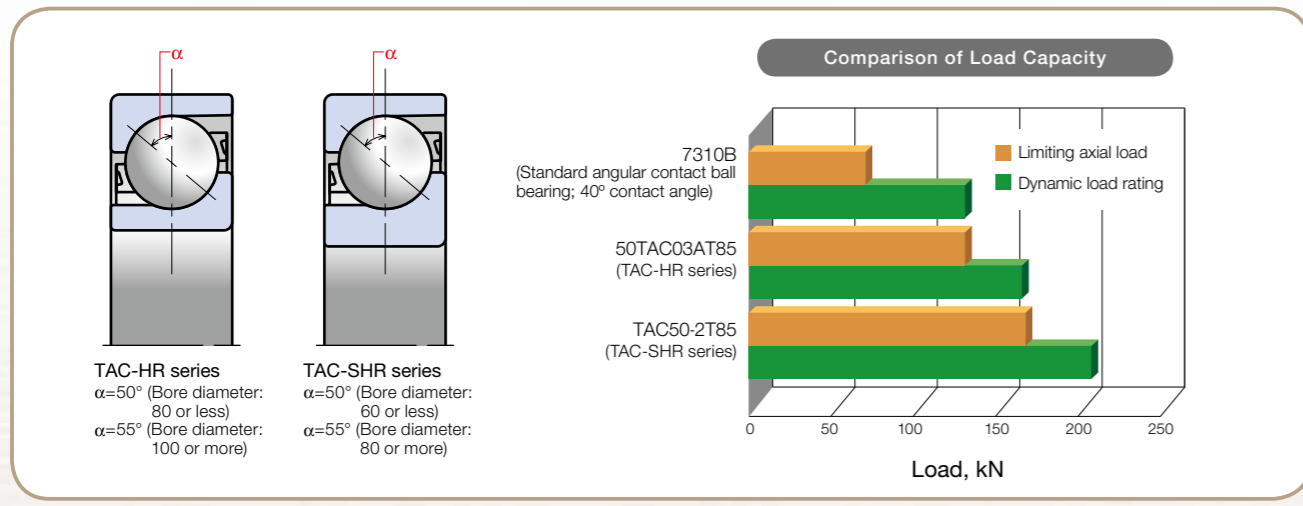
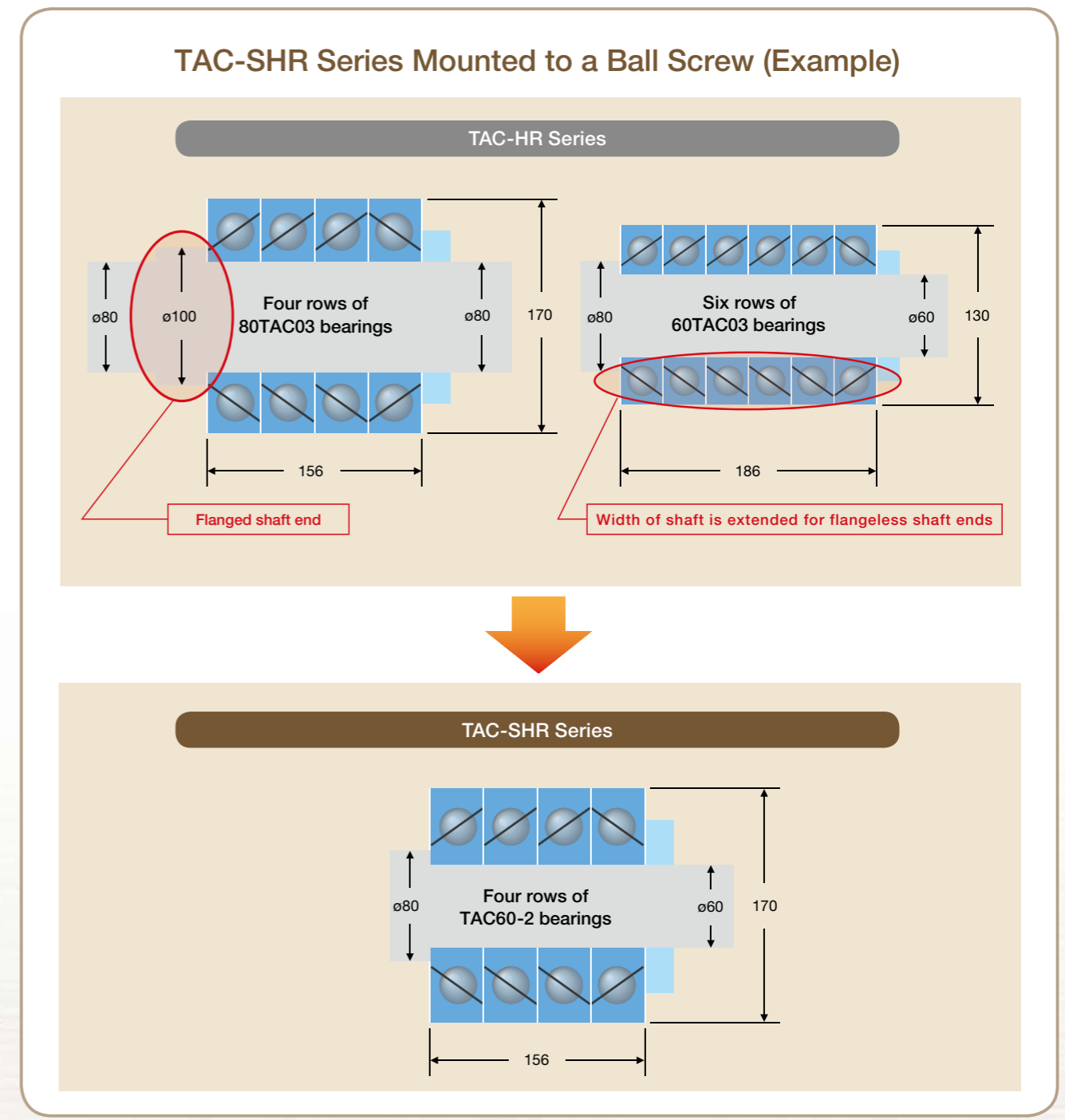

TAC Series of Ball Screw Support Bearings for High-Load Applications

TAC-HR Series Bearing Specifications

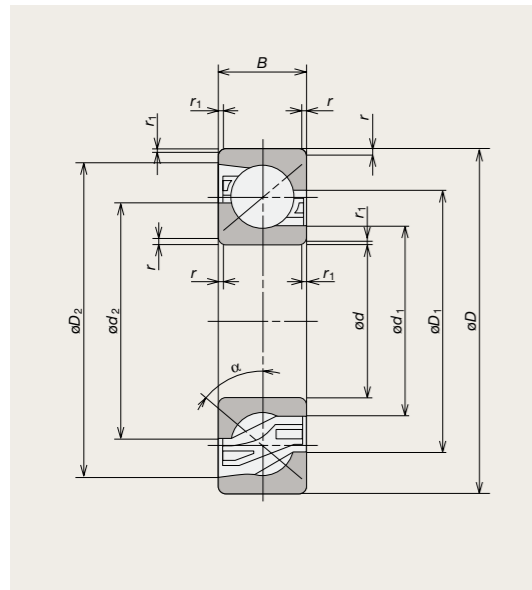

Bearing numbers	Boundary dimensions (mm)					Dimensions (mm)		Dimensions (mm)		Contact angle α	Recommended amount of prepacked grease (cc)	Limiting speed (min ⁻¹)	Basic dynamic load rating C_a by number of rows sustaining F_a						Limiting axial load by number of rows sustaining F_a					
	d	D	B	r	r_1	d_1	d_2	D_1	D_2				1 row (kN)	2 rows (kN)	3 rows (kN)	4 rows (kN)	5 rows (kN)	6 rows (kN)	1 row (kN)	2 rows (kN)	3 rows (kN)	4 rows (kN)	5 rows (kN)	6 rows (kN)
25TAC02AT85	25	52	15	1	0.6	30.5	36.6	40.4	47.4	50	3	7 700	33.5	54.5	72	88	103	117	22.5	45.5	68	90	112.5	135
40TAC03AT85	40	90	23	1.5	1	49.7	61.4	68.6	81.9	50	15	4 600	102	166	220	269	315	360	61	122	183	244	305	366
45TAC03AT85	45	100	25	1.5	1	55.8	68.6	76.4	91	50	19	4 100	120	195	259	315	370	420	91.5	183	274	365	455	548
50TAC03AT85	50	110	27	2	1	60.3	75.6	84.5	100.9	50	27	3 700	150	243	325	395	460	525	116	232	350	464	580	696
55TAC03AT85	55	120	29	2	1	67.1	82.7	92.3	110.1	50	32	3 400	171	278	370	450	530	600	133	266	400	532	665	798
60TAC03AT85	60	130	31	2.1	1.1	72.1	89.8	100.2	119.4	50	54	3 100	196	320	425	520	605	690	152	305	455	608	760	912
80TAC03AM	80	170	39	2.1	1.1	94	118.5	131.5	152.5	50	82	2 400	274	445	590	720	845	960	238	475	715	952	1 190	1 428
100TAC03CMC	100	215	47	3	1.1	122.5	156.9	158.1	188.1	55	120	1 900	365	595	795	970	1 130	1 290	231	460	690	924	1 155	1 386
120TAC03CMC	120	260	55	3	1.1	153	189.3	190.7	223.5	55	170	1 500	430	700	930	1 140	1 330	1 510	295	590	885	1 180	1 475	1 770

Dynamic equivalent load

Angular contact thrust ball bearings for electric injection molding machines are subjected to extremely large axial loads (F_a) in comparison to radial loads (F_r). The F_a/F_r ratio far exceeds constant e (when contact angle α is 50°, e is 1.49; when contact angle α is 55°, e is 1.79). Therefore, the dynamic equivalent load P of the support bearing is obtained by the following formula regardless of the number of rows:
 When contact angle α is 50°, P is $0.73 F_r + F_a$
 When contact angle α is 55°, P is $0.81 F_r + F_a$

TAC-SHR Series Bearing Specifications

Bearing numbers	Boundary dimensions (mm)					Dimensions (mm)		Dimensions (mm)		Contact angle α	Recommended amount of prepacked grease (cc)	Limiting speed (min ⁻¹)	Basic dynamic load rating C_a by number of rows sustaining F_a						Limiting axial load by number of rows sustaining F_a					
	d	D	B	r	r_1	d_1	d_2	D_1	D_2				1 row (kN)	2 rows (kN)	3 rows (kN)	4 rows (kN)	5 rows (kN)	6 rows (kN)	1 row (kN)	2 rows (kN)	3 rows (kN)	4 rows (kN)	5 rows (kN)	6 rows (kN)
TAC35-2T85	35	90	23	1.5	1	49.7	61.4	68.6	81.9	50	15	4 600	102	166	220	269	315	360	61	122	183	244	305	366
TAC40-2T85	40	110	27	1.5	1	60.3	75.6	84.5	100.9	50	27	3 700	150	243	325	395	460	525	116	232	350	464	580	696
TAC45-2T85	45	110	27	2	1	60.3	75.6	84.5	100.9	50	27	3 700	150	243	325	395	460	525	116	232	350	464	580	696
TAC50-2T85	50	130	31	2.1	1.1	72.1	89.8	100.2	119.4	50	54	3 100	196	320	425	520	605	690	152	305	455	608	760	912
TAC60-2M	60	170	39	2.1	1.1	94	118.5	131.5	152.5	50	82	2 400	274	445	590	720	845	960	238	475	715	952	1 190	1 428
TAC80-2MC	80	215	47	2.1	1.1	122.5	156.9	158.1	188.1	55	120	1 900	365	595	795	970	1 130	1 290	231	460	690	924	1 155	1 386
TAC100-2MC	100	260	55	3	1.1	153	189.3	190.7	223.5	55	170	1 500	430	700	930	1 140	1 330	1 510	295	590	885	1 180	1 475	1 770

Ball Screw Shaft Diameters and Recommended TAC Series

Shaft diameter (mm)	TAC-HR Series	TAC-SHR Series
40, 45	25TAC02	TAC35-2
50	40TAC03	TAC40-2
63	50TAC03	TAC50-2
80	60TAC03	TAC60-2
100	80TAC03	TAC80-2
120	100TAC03	TAC100-2
140	120TAC03	—

Remarks:

1. Chamfer dimensions r and r_1 of boundary dimensions listed in the bearing specifications are minimum values.
2. The number of rows for the basic dynamic load ratings and limiting axial loads show the number of bearing rows for the primary axially loaded side. Do not confuse this number of rows with the number of rows for the entire assembly. (1 row: DB, DF; 2 rows: DT, DBB, DBD, DFD, DFF; 3 rows: DTD, DBT, DFT)
3. The limiting axial load is the limiting value of the ball during raceway-shoulder transition (ball overhang). Therefore, the permissible axial load for the bearing selection should be each value described above multiplied by 0.7.
4. Please contact NSK for bearings not listed in the specifications above.

NSK Roller Guides RA Series

The RA series' roller guides feature high-load capacity and high rigidity and help to preserve the working environment. This series is the culmination of NSK's analysis technology and tribology.

Demand for preloaded rolling linear guides for high-load drive is now increasing. The RA series with high rigidity and a function for preserving a clean environment is one of the most suitable linear guides for high-load applications.

High-load capacity

The world's highest-load capacity, taking full advantage of NSK's analysis technology, ensures a long operating life.

High rigidity

The optimum size of the roller ensures high rigidity and supports more compact machinery.

Highly dust-resistant design

A high-performance seal, provided as standard equipment, prevents the entry of foreign matter and maintains the roller guides at its original level of sound performance for extended periods of time.

Interchangeable series (Random assembly series of guide rails and roller slides)

The interchangeable series of the guide rails and the roller slides are independently available in stock. They can be randomly matched and assembled in accordance with the applicable code of accuracy and preload for prompt delivery.



Optimal Design

NSK executed a comprehensive, detailed performance simulation of roller guides by integrating its analysis technology and the tribology technology that the company had been developing over many years. Down to the dimensions and shapes of component details, we have attained an optimal design completely.

Smooth motion by use of retaining pieces

Balanced four-directional iso-load specifications

Example of roller slide deformation analysis

Analysis example of contact pressure distribution of rollers

Specifications

Roller Slide Types and Shapes

- Two types of roller slides are available in this series: a flange type and a square type.
- A compact, low-profile square type is now available.
- On the mounting hole of the flange type, the tapped part is used to fix the roller slide from the top surface, and the minor diameter can be used as a bolt hole from the bottom. This provides mounting from both directions, top and bottom.
- Roller slide length can be specified by the standard high-load type or special long, super-high load type.

Fig. 1 Square type (RA15, 20, 25, 30, 35, 45, 55, and 65)

Roller slide shape code

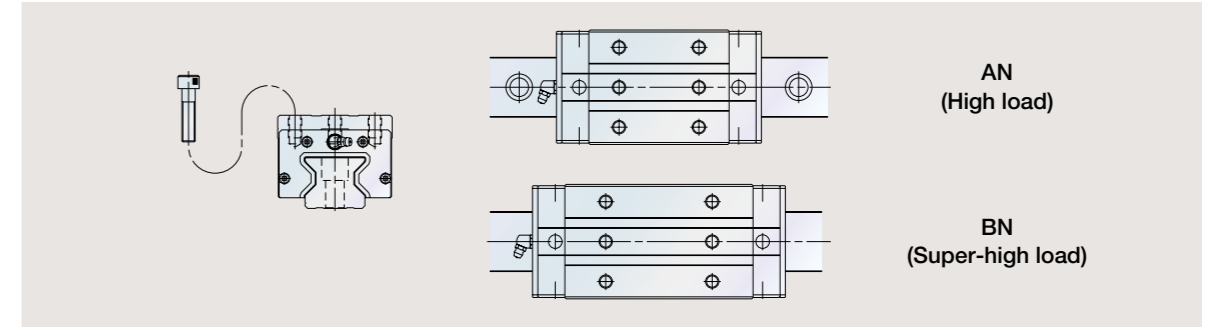

Fig. 2 Low-profile type (RA15, 25, 30, 35, 45, and 55)

Roller slide shape code

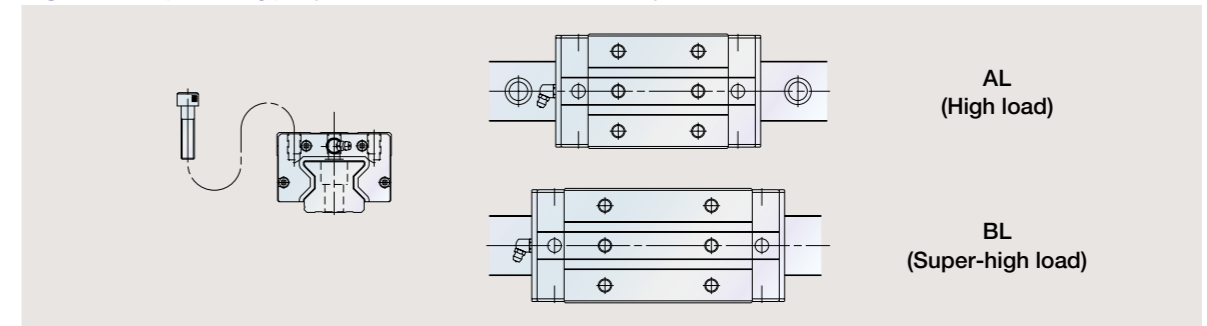
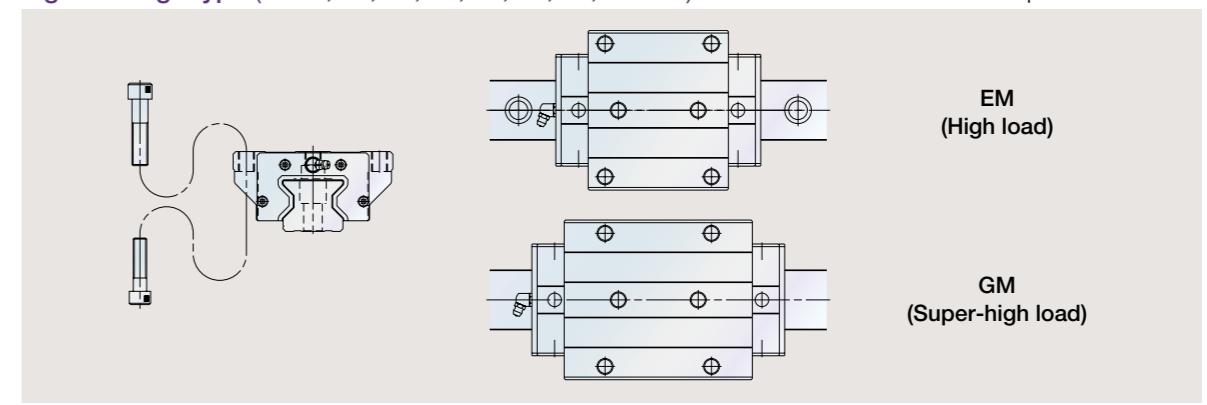

Fig. 3 Flange type (RA15, 20, 25, 30, 35, 45, 55, and 65)

Roller slide shape code



Please refer to Cat. No. E3328 for more details.

Worldwide Sales Offices

NSK LTD.-HEADQUARTERS, TOKYO, JAPAN INDUSTRIAL MACHINERY BEARINGS DIVISION-HEADQUARTERS AFTERMARKET BUSINESS DIVISION-HEADQUARTERS AUTOMOTIVE BUSINESS DIVISION-HEADQUARTERS PRECISION MACHINERY & PARTS DIVISION-HEADQUARTERS	www.nsk.com tel: 03-3779-7227 tel: 03-3779-8893 tel: 03-3779-7189 tel: 03-3779-7163	Indonesia: PT. NSK INDONESIA Jakarta Korea: NSK KOREA CO., LTD. Seoul Changwon	www.id.nsk.com tel: 021-252-3458 www.kr.nsk.com tel: 02-3287-0300 tel: 055-287-6001	INDUSTRIA CUSCINE TTI S.P.A. Torino Poland: NSK EUROPE LTD. WARSAW LIAISON OFFICE Warsaw NSK EUROPEAN TECHNOLOGY CENTER, POLAND OFFICE Kielce NSK STEERING SYSTEMS EUROPE (POLSKA) SP.ZO.O. Walbrzych NSK NEEDLE BEARING POLAND SP.ZO.O. Kielce	tel: 011-982-4811 tel: 022-645-1525 tel: 041-366-5812 tel: 074-664-4101 tel: 041-345-2469
Africa South Africa: NSK SOUTH AFRICA (PTY) LTD. Johannesburg	tel: 011-458-3600	Malaysia: NSK BEARINGS (MALAYSIA) SDN BHD Shah Alam New Zealand: NSK NEW ZEALAND LTD. Auckland	www.my.nsk.com tel: 03-7803-8859 www.nsk-rhp.co.nz tel: 09-276-4992	Spain: NSK SPAIN S.A. Barcelona Turkey: NSK RULMANLARI ORTA DOGU TIC. LTD. STI. Istanbul United Kingdom: NSK EUROPEAN TECHNOLOGY CENTRE Newark NSK UK Ltd. Newark NSK PRECISION UK LTD. Newark NSK STEERING SYSTEMS EUROPE LTD. Maidenhead	tel: 093-433-5775 tel: 0216-355-0398 tel: 01636-605-123 tel: 01636-605-123 tel: 01636-605-123 tel: 01628-509-800
Asia and Oceania Australia: NSK AUSTRALIA PTY. LTD. Melbourne China: NSK HONG KONG LTD. Hong Kong Shenzhen KUNSHAN NSK CO., LTD. Kunshan CHANGSHU NSK NEEDLE BEARING CO., LTD. Jiangsu NSK STEERING SYSTEMS DONGGUAN CO., LTD. Dongguan NSK CHINA TECHNOLOGY CENTER Jiangsu NSK (SHANGHAI) TRADING CO., LTD. Shanghai NSK (CHINA) INVESTMENT CO., LTD. Shanghai Beijing Guangzhou Chengdu NSK CHINA SALES CO., LTD. Shanghai Changchun Tianjin Nanjing Chongqing AKS PRECISION BALL (HANGZHOU) CO., LTD. Hangzhou	www.au.nsk.com tel: 03-9764-8302 tel: 2739-9933 tel: 0755-25904886 tel: 0512-5771-5654 tel: 0512-5230-1111 tel: 0769-2262-0960 tel: 0512-5771-5654 tel: 021-6235-0198 tel: 021-6235-0198 tel: 021-6235-0198 tel: 020-3786-4833 tel: 028-8661-4200 tel: 021-6235-0198 tel: 0431-8898-8682 tel: 022-8319-5030 tel: 025-8472-6671 tel: 023-6806-5310 tel: 0571-2280-1288	Philippines: NSK REPRESENTATIVE OFFICE Manila Singapore: NSK INTERNATIONAL (SINGAPORE) PTE LTD. Singapore NSK SINGAPORE (PRIVATE) LTD. Singapore Taiwan: TAIWAN NSK PRECISION CO., LTD. Taipei TAIWAN NSK TECHNOLOGY CO., LTD. Taipei Thailand: NSK BEARINGS (THAILAND) CO., LTD. Bangkok NSK BEARINGS MANUFACTURING (THAILAND) CO., LTD. Chonburi SIAM NSK STEERING SYSTEMS CO., LTD. Chachoengsao NSK ASIA PACIFIC TECHNOLOGY CENTER (THAILAND) CO., LTD. Chonburi Vietnam: NSK VIETNAM CO., LTD. Hanoi NSK REPRESENTATIVE OFFICE Ho Chi Minh City	tel: 02-893-9543 tel: 6496-8000 tel: 6496-8000 tel: 02-2509-3305 tel: 02-2509-3305 tel: 02641-2150 tel: 038-454-010 tel: 038-522-343 tel: 038-454-631 tel: 04-3955-0159 tel: 08-3822-7907 tel: 02641-2150 tel: 01628-509-800 tel: 01-30-57-39-39 tel: 02102-4810 tel: 02102-4810 tel: 0299-5191	North and South America NSK AMERICAS, INC. (AMERICAN HEADQUARTERS) Ann Arbor Argentina: NSK ARGENTINA SRL Buenos Aires Brazil: NSK BRASIL LTDA. São Paulo Canada: NSK CANADA INC. Toronto Mexico: NSK RODAMIENTOS MEXICANA, S.A. DE C.V. Mexico City United States of America: NSK CORPORATION Ann Arbor NSK AMERICAN TECHNOLOGY CENTER Ann Arbor NSK PRECISION AMERICA, INC. Franklin NSK STEERING SYSTEMS AMERICA, INC. Bennington NSK LATIN AMERICA, INC. Miami	tel: 734-913-7500 tel: 11-4704-5100 tel: 011-3269-4786 tel: 905-890-0740 tel: 55-5390-4312 tel: 734-913-7500 tel: 734-913-7500 tel: 317-738-5000 tel: 802-442-5448 tel: 305-477-0605
India: RANE NSK STEERING SYSTEMS LTD. Chennai NSK INDIA SALES CO. PVT. LTD. Chennai Gurgaon Kolkata Mumbai NSK-ABC BEARINGS LTD. Chennai	tel: 044-274-66002 tel: 044-2433-1161 tel: 0124-4104-530 tel: 033-4001-2062 tel: 022-2838-7787 tel: 044-2714-3000	Europe NSK EUROPE LTD. (EUROPEAN HEADQUARTERS) Maidenhead France: NSK FRANCE S.A.S Paris Germany: NSK DEÜTSCHLAND GMBH Düsseldorf NSK PRECISION EUROPE GMBH Düsseldorf Italy: NSK ITALIA S.P.A. Milano	tel: 01628-509-800 tel: 01-30-57-39-39 tel: 02102-4810 tel: 02102-4810 tel: 0299-5191		

NSK Ltd. has a basic policy not to export any products or technology designated as controlled items by export-related laws. When exporting the products in this brochure, the laws of the exporting country must be observed. Specifications are subject to change without notice and without any obligation on the part of the manufacturer. Every care has been taken to ensure the accuracy of the data contained in this brochure, but no liability can be accepted for any loss or damage suffered through errors or omissions. We will gratefully acknowledge any additions or corrections.

For more information about NSK products, please contact: _____

