

# Precision Machine Components

---

- **Ball Screws**

OUR CAD-MODELS AVAILABLE AT:  
  
[nsk.solidcomponents.com](http://nsk.solidcomponents.com)

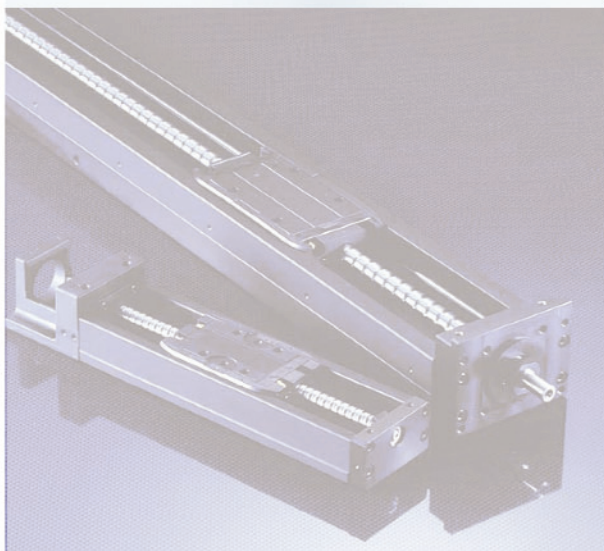
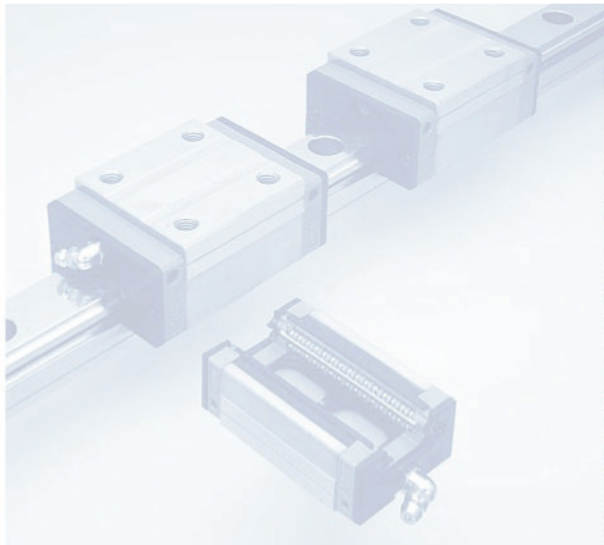

## Precision Rolled Ball Screws

### Main features:

Compact ball nut heralding in the next generation standard.  
Extended maintenance free operation with NSK K1®  
lubrication unit and new grease retaining seal.  
Suitable for high speed and long stroke operation.

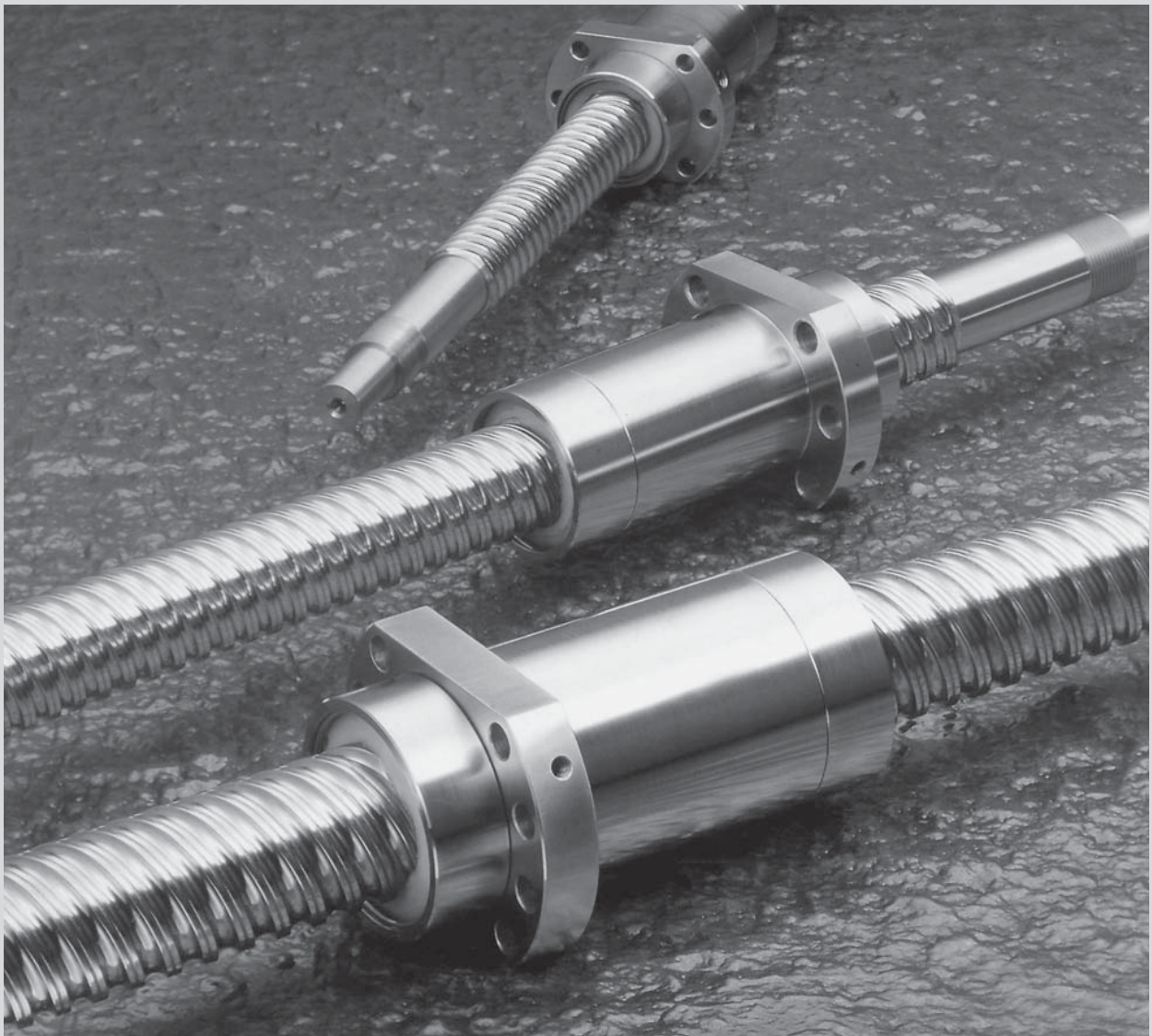

**13**



## 1. Precision Rolled Ball Screws PR Series/LPR Series

### 1.1 Specification Number

For ordering, please quote the specification number.

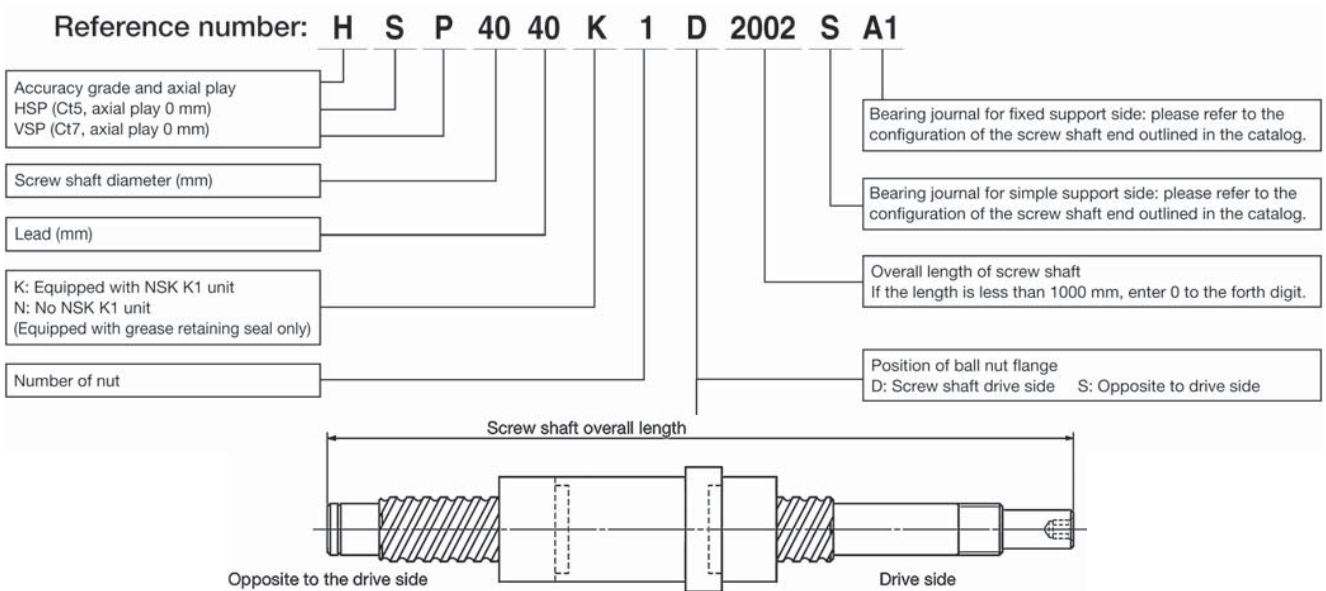

### 1.2 Permissible rotational speed of precision rolled ball screws

We strongly recommend reviewing the allowable speed of the screw shaft.

The allowable rotational speed of the ball screw shall be checked on the following.

- $d \cdot N$  value, which is involved in damaging the ball re-circulation components  
(Where,  $d$ : shaft diameter measured in mm,  $N$ : rotational speed measured in  $\text{min}^{-1}$ )
- Critical speed of the screw shaft (caused by the resonance of the screw shaft)
- Permissible  $d \cdot N$

Preferably  $d \cdot N \leq 150\,000$ . Please consult with NSK if your ball screw exceeds the limitation.

- Critical speed

See the chart below. For detailed calculations, please refer to the catalog: Precision Machine Component (CAT No. E3161).

Please consult NSK if the maximum rotational speed exceeds  $5\,000 \text{ min}^{-1}$ , even both the critical speed of the screw shaft rotation and the  $d \cdot N$  value are in ranges of the allowable limit.

Permissible rotational speed vs. critical speed.

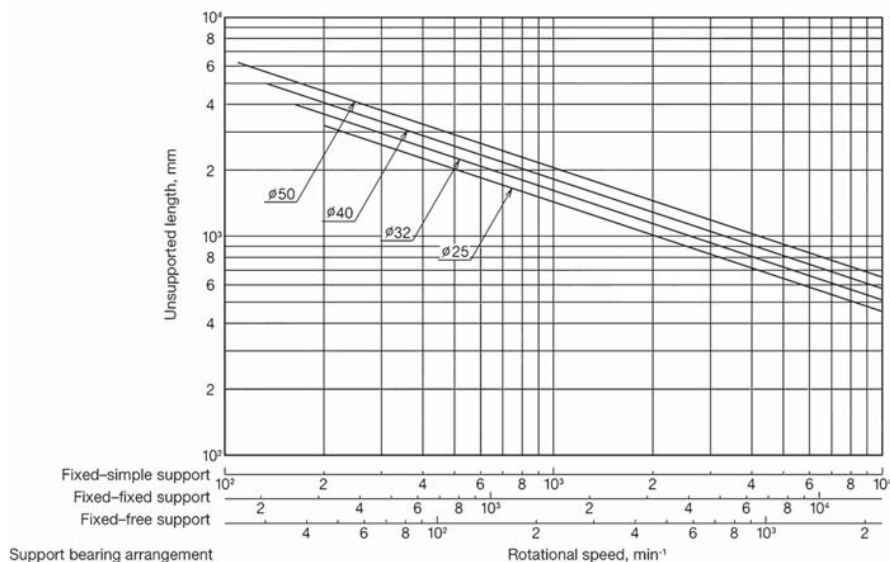

### Precision Rolled Ball Screws PR and LPR Series

#### Ball nut dimensions

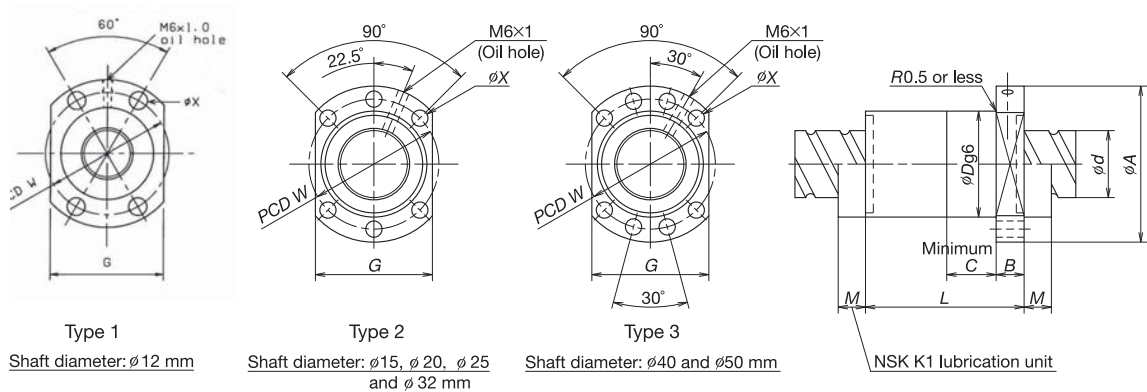

#### PR Series

Unit: mm

Model No.	Shaft diameter	Lead	Effective turns of balls	Basic load rating (N)		Dimensions									Maximum screw shaft length	
	$d$	$l$		Dynamic load rating $C_a$	Static load rating $C_{0a}$	$D$	$A$	$G$	$B$	$L$	$C$	$W$	$X$	$M^{**}$	Ct5	Ct7
PR1205	12	5	2.7x1	3 200	5 860	24	40	26	11	30	10	32	4.5	(18)	500	900
PR1505	15	5	2.7x1	5 460	10 200	28	48	40	11	30	10	38	5.5	(18)	600	1 200
PR1510	15	10	2.7x1	5 460	10 200	28	48	40	11	43	15	38	5.5	(18)	600	1 200
PR2005	20	5	2.7x1	8 790	18 500	36	58	44	13	31	10	47	6.6	(18)	800	1 600
PR2010	20	10	2.7x1	8 790	18 500	36	58	44	13	45	15	47	6.6	(18)	800	1 600
PR2505	25	5	3.7x1	15 700	40 900	40	62	48	12	42	10	51	6.6	(21)	2 500	3 200
PR2510	25	10	3.7x1	12 800	32 300	40	62	48	12	56	15	51	6.6	(21)	2 500	3 200
PR3210	32	10	3.7x1	19 000	51 500	50	80	62	12	59	10	65	9	(21)	3 200	4 000
PR3220	32	20	3.7x1	19 000	51 500	50	80	62	12	98	15	65	9	(21)	3 200	4 000
PR4010	40	10	3.7x1	33 800	89 900	63	93	70	14	60	10	78	9	(21)	1 600	3 200

#### LPR Series

Unit: mm

Model No.	Shaft diameter	Lead	Effective turns of balls	Basic load rating (N)		Dimensions									Maximum screw shaft length	
	$d$	$l$		Dynamic load rating $C_a$	Static load rating $C_{0a}$	$D$	$A$	$G$	$B$	$L$	$C$	$W$	$X$	$M$	Ct5	Ct7
LPR2020	20	20	1.7x2	9 890	21 600	36	58	44	13	54	25	47	6.6	(18)	800	1 600
LPR2525	25	25	1.7x2	11 000	27 500	40	62	48	12	63	30	51	6.6	(21)	2 500	3 200
LPR3232	32	32	1.7x2	16 300	43 900	50	80	62	14	79	40	65	9	(21)	3 200	4 000
LPR4040	40	40	1.7x2	29 000	76 200	63	93	70	16	94	45	78	9	(21)	4 000	6 500
LPR5050	50	50	1.7x2	32 200	96 200	75	110	85	18	115	45	93	11	(21)	4 000	6 500

\* Please, consult NSK.

\*\* only for reference.

## 2. Recommendation of Screw Shaft End Configuration

### 2.1 Drive side shaft end and opposite end: P

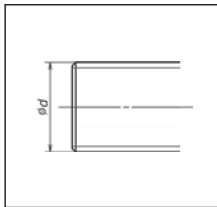

Unit: mm

Screw shaft Diameter $d$
12
15
20
25
32
40
50

### 2.2 Drive side shaft end and opposite end: R

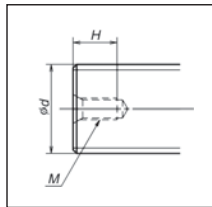

Screw shaft Diameter $d$	Tap hole	
	Size $M$	Depth $H$
12	M3×0.5	9
15	M4×0.7	10
20	M6×1	12
25	M6×1	12
32	M6×1	12
40	M8×1.25	16
50	M8×1.25	16

### 2.3 Opposite to drive side shaft end: S

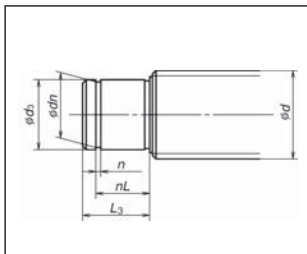

Support unit Reference number	Screw shaft Diameter $d$	Bearing journal Diameter $d_3$ g6	Bearing journal Length $L_3$	Snap ring groove		
				Width $n$ Tolerance	Diameter $dn$ Tolerance	Position $nL$
WBK08S-01	12	6	9	$0.8^{+0.1}_0$	$5.7^{0}_{-0.06}$	6.8
WBK12S-01	15	10	12	$1.15^{+0.14}_0$	$9.6^{0}_{-0.09}$	9.15
WBK15S-01	20	15	13	$1.15^{+0.14}_0$	$14.3^{0}_{-0.11}$	10.15
WBK20S-01	25	20	19	$1.35^{+0.14}_0$	$19^{0}_{-0.21}$	15.35
WBK25S-01	32	25	20	$1.35^{+0.14}_0$	$23.9^{0}_{-0.21}$	16.35
(6206)	40	30	22	$1.75^{+0.14}_0$	$28.6^{0}_{-0.21}$	17.75
(6207)	50	35	25	$1.75^{+0.14}_0$	$33^{0}_{-0.21}$	18.75

( ): Reference number of bearing

### 2.4 Opposite to drive side shaft end: T

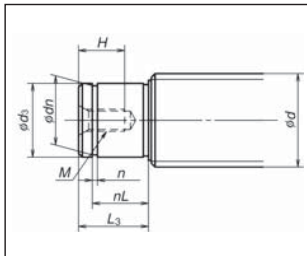

Support unit Reference number	Screw shaft Diameter $d$	Bearing journal Diameter $d_3$ g6	Bearing journal Length $L_3$	Snap ring groove			Tap hole	
				Width $n$ Tolerance	Diameter $dn$ Tolerance	Position $nL$	Size $M$	Depth $H$
WBK08S-01	12	6	9	$0.8^{+0.1}_0$	$5.7^{0}_{-0.06}$	6.8	—	—
WBK12S-01	15	10	12	$1.15^{+0.14}_0$	$9.6^{0}_{-0.09}$	9.15	M3×0.5	9
WBK15S-01	20	15	13	$1.15^{+0.14}_0$	$14.3^{0}_{-0.11}$	10.15	M3×0.8	10
WBK20S-01	25	20	19	$1.35^{+0.14}_0$	$19^{0}_{-0.21}$	15.35	M6×1.0	12
WBK25S-01	32	25	20	$1.35^{+0.14}_0$	$23.9^{0}_{-0.21}$	16.35	M6×1.0	12
(6206)	40	30	22	$1.75^{+0.14}_0$	$28.6^{0}_{-0.21}$	17.75	M8×1.25	16
(6207)	50	35	25	$1.75^{+0.14}_0$	$33^{0}_{-0.21}$	18.75	M8×1.25	16

( ): Reference number of bearing

### 2.5 Drive side shaft end: C Opposite to drive side shaft end: U

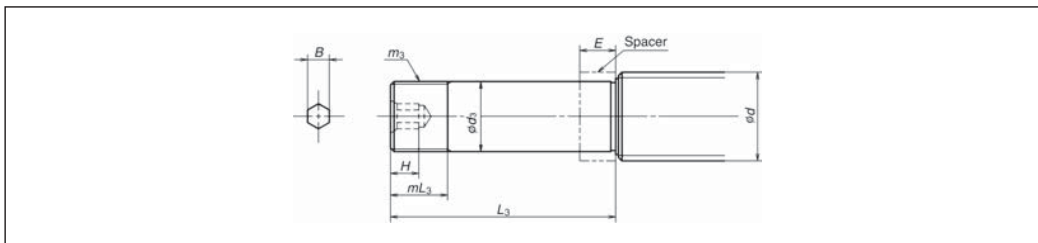

Unit: mm

Support unit		Spacer	Screw shaft	Bearing journal	Lock nut thread		Hexagon hole	
Reference number		Reference number	Diameter $d$	Diameter $d_3$ g6	Nominal $m_3$	Length $mL_3$	Width across the flats $B^{+0.03}$	Depth $H$
WBK08-01A	WBK08-11	WBK08K	12	8	32	M8×1	9	—
WBK12-01A	WBK12-11	WBK12K	15	12	35	M12×1	10	4
WBK15-01A	WBK15-11	WBK15K	20	15	50	M15×1	15	5
WBK20-01	WBK20-11	WBK20K	25	20	64	M20×1	16	6
WBK25-01	WBK25-11	WBK25K	32	25	76	M25×1.5	20	8
WBK30DF-31	—	—	40	30	89	M30×1.5	26	10
WBK35DF-31	—	—	50	35	92	M35×1.5	30	12

### 2.6 Opposite to drive side shaft end: V

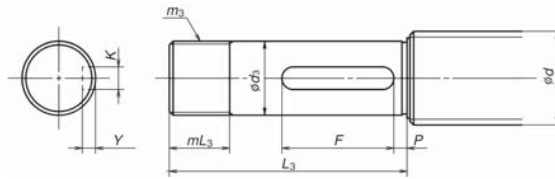

Unit: mm

Support unit		Screw shaft	Bearing journal		Lock nut thread		Key seat			
Reference number		Diameter $d$	Diameter $d_3$ g6	Length $L_3$	Nominal $m_3$	Length $mL_3$	Width $K$ N9	Position $P$	Depth $Y$ $^{+0.1}$	Length $F$
WBK08-01A	WBK08-11	12	8	32	M8×1	9	2	3	1.2	14
WBK12-01A	WBK12-11	15	12	35	M12×1	10	4	3	2.5	20
WBK15-01A	WBK15-11	20	15	50	M15×1	15	5	3	3	25
WBK20-01	WBK20-11	25	20	64	M20×1	16	6	4	3.5	30
WBK25-01	WBK25-11	32	25	76	M25×1.5	20	8	4	4	40
WBK30DF-31		40	30	89	M30×1.5	26	8	5	4	40
WBK35DF-31		50	35	92	M35×1.5	30	10	5	5	50

### 2.7 Drive side shaft end: A1

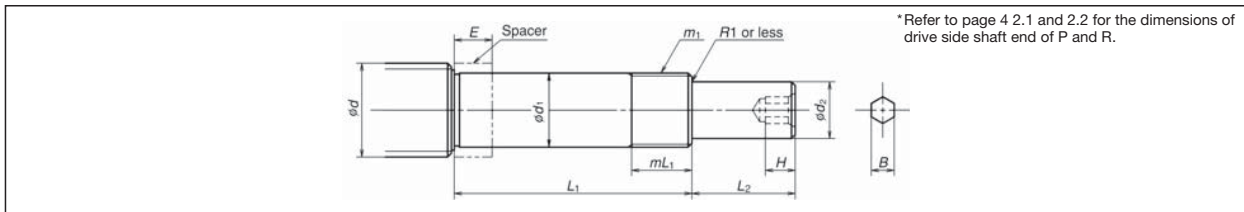

Unit: mm

Support unit		Spacer	Screw shaft	Bearing journal	Lock nut thread		Drive section		Hexagon hole		
Reference number		Reference number	Diameter $d$	Diameter $d_1$ g6	Length $L_1$	Nominal $m_3$	Length $mL_1$	Diameter $d_2$ $h_7$	Length $L_2$	Width across the flats $B$ $^{+0.2}$	Depth $H$
WBK08-01A	WBK08-11	WBK08K	12	8	32	M8×1	9	6	10	—	—
WBK12-01A	WBK12-11	WBK12K	15	12	35	M12×1	10	10	15	4	6
WBK15-01A	WBK15-11	WBK15K	20	15	50	M15×1	15	12	20	5	7
WBK20-01	WBK20-11	WBK20K	25	20	64	M20×1	16	15	27	6	8
WBK25-01	WBK25-11	WBK25K	32	25	76	M25×1.5	20	20	33	8	10
WBK30DF-31		—	40	30	89	M30×1.5	26	25	61	10	12
WBK35DF-31		—	50	35	92	M35×1.5	30	30	63	12	14

### 2.8 Drive side shaft end: A3

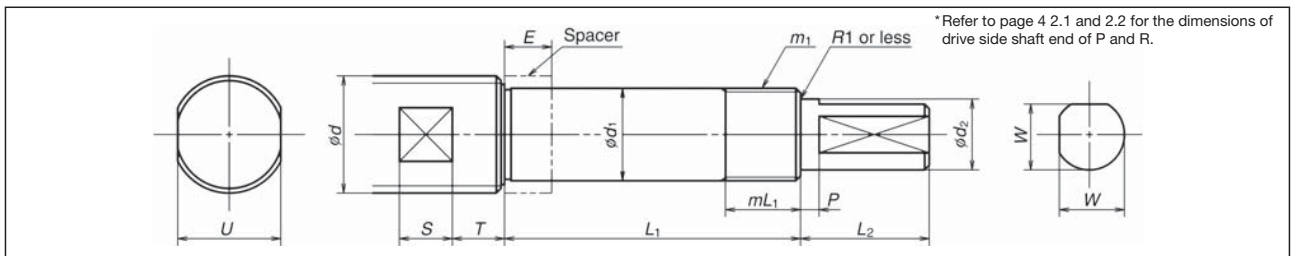

Unit: mm

Support unit		Spacer	Screw shaft	Bearing journal	Lock nut thread		Drive section		D		Wrench flats			
Reference number		Reference number	Diameter $d$	Diameter $d_1$ g6	Length $L_1$	Nominal $m_1$	Length $mL_1$	Diameter $d_2$ $h_7$	Length $L_2$	Position $P$	Depth $W$	Width across the flats $U$ Tolerance	Position $T$	Length $S$
WBK08-01A	WBK08-11	WBK08K	12	8	32	M8×1	9	6	10	2	5.5	$10_{-0.2}^0$	4	5.5
WBK12-01A	WBK12-11	WBK12K	15	12	35	M12×1	10	10	15	3	9	$12_{-0.25}^0$	6	6.5
WBK15-01A	WBK15-11	WBK15K	20	15	50	M15×1	15	12	20	3	11	$17_{-0.25}^0$	6	8.5
WBK20-01	WBK20-11	WBK20K	25	20	64	M20×1	16	15	27	4	14	$22_{-0.3}^0$	10	11
WBK25-01	WBK25-11	WBK25K	32	25	76	M25×1.5	20	20	33	4	19	$32_{-0.3}^0$	10	15
WBK30DF-31		—	40	30	89	M30×1.5	26	25	61	5	24	$36_{-0.3}^0$	16	16
WBK35DF-31		—	50	35	92	M35×1.5	30	30	63	5	29	$41_{-0.3}^0$	16	18



## 2.9 Drive side shaft end: A4

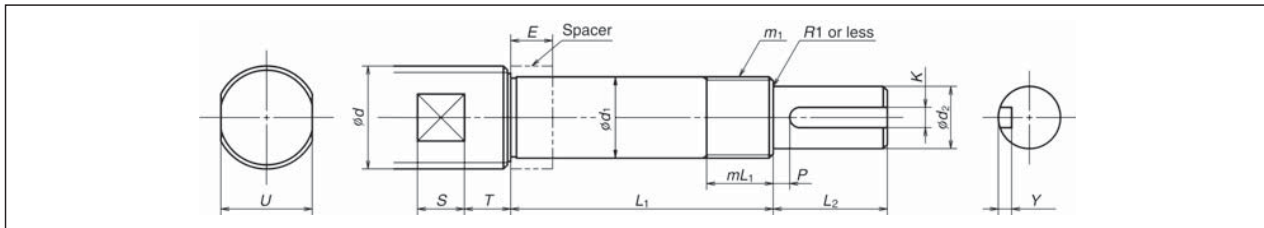

Unit: mm

Support unit		Spacer	Screw shaft	Bearing journal	Lock nut thread		Drive section		Key seat			Wrench flats			
Reference number		Reference number	Diameter	Diameter	Length	Nominal	Length	Diameter	Length	Width	Position	Depth	Width across the flats	Position	Length
			$d$	$d_1$ g6	$L_1$	$m_1$	$mL_1$	$d_2$ h7	$L_2$	$K$ N9	$P$	$Y^{+0.1}$	$U$ Tolerance	$T$	$S$
WBK08-01A	WBK08-11	WBK08K	12	8	32	M8×1	9	6	10	–	–	–	$10^{+0.2}$	4	5.5
WBK12-01A	WBK12-11	WBK12K	15	12	35	M12×1	10	10	15	2	3	1.2	$12^{+0.25}$	6	6.5
WBK15-01A	WBK15-11	WBK15K	20	15	50	M15×1	15	12	20	4	3	2.5	$17^{+0.25}$	6	8.5
WBK20-01	WBK20-11	WBK20K	25	20	64	M20×1	16	15	27	5	4	3	$22^{+0.3}$	10	11
WBK25-01	WBK25-11	WBK25K	32	25	76	M25×1.5	20	20	33	6	4	3.5	$32^{+0.3}$	10	15
WBK30DF-31	–	–	40	30	89	M30×1.5	26	25	61	8	5	4	$36^{+0.3}$	16	16
WBK35DF-31	–	–	50	35	92	M35×1.5	30	30	63	8	5	4	$41^{+0.3}$	16	18

## 2.10 Drive side shaft end: A5

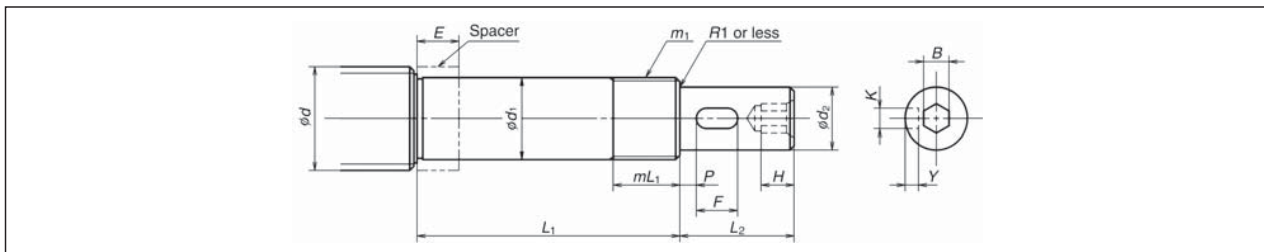

Unit: mm

Support unit		Spacer	Screw shaft	Bearing journal	Lock nut thread		Drive section		Key seat				Wrench flats		
Reference number		Reference number	Diameter	Diameter	Length	Nominal	Length	Diameter	Length	Width	Position	Depth	Length	Width across the flats	Depth
			$d$	$d_1$ g6	$L_1$	$m_1$	$mL_1$	$d_2$ h7	$L_2$	$K$ N9	$P$	$Y^{+0.1}$	$F$	$B^{+0.2}$	$H$
WBK08-01A	WBK08-11	WBK08K	12	8	32	M8×1	9	6	10	–	–	–	–	–	–
WBK12-01A	WBK12-11	WBK12K	15	12	35	M12×1	10	10	15	–	–	–	–	4	6
WBK15-01A	WBK15-11	WBK15K	20	15	50	M15×1	15	12	20	4	3	2.5	7	5	7
WBK20-01	WBK20-11	WBK20K	25	20	64	M20×1	16	15	27	5	4	3	10	6	8
WBK25-01	WBK25-11	WBK25K	32	25	76	M25×1.5	20	20	33	6	4	3.5	15	8	10
WBK30DF-31	–	–	40	30	89	M30×1.5	26	25	61	8	5	4	40	10	12
WBK35DF-31	–	–	50	35	92	M35×1.5	30	30	63	8	5	4	40	12	14

## 2.11 Spacer

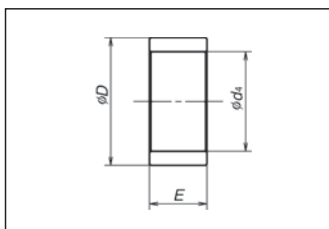

Unit: mm

Reference number	Bearing journal	Spacer dimensions		
	Diameter $d$	Bore $d_4$	Diameter $D$	Width $E$
WBK08K	8	8	11.5	5.5
WBK12K	12	12	14.5	5.5
WBK15K	15	15	19.5	10
WBK20K	20	20	25.5	11
WBK25K	25	25	32	14

## Rolled Ball Screws R-Series

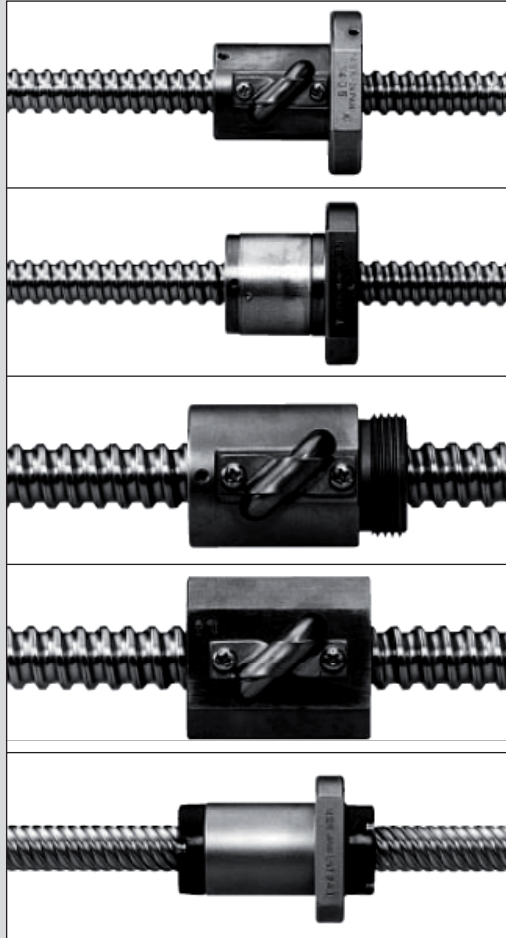





- Short delivery time: R Series is standardized, and available in stock.
- Interchangeable screw shaft and ball nut: Screw shaft and nut assembly components are sold separately, and randomly-matched. The maximum axial play after assembly is shown in the dimension tables.
- Low prices: Screw shaft is processed by rolling. This is why prices are lower than those of precision types.
- Abundant series: There are 128 types of nut assembly combinations in the series. Each combination has two to three different lengths in screw shaft.





### Rolled Ball Screws

Nut model	Picture group		Recirculation system	Lead classification
RNFTL		Flanged, Tube projecting type	Return tube type	Fine, medium lead High helix lead
RNFBL		Flanged Circular	Return tube type	Fine, medium lead
RNCT		V-thread (no flange) Projecting tube type	Return tube type	Fine lead
RNSTL		Square type	Return tube type	Small, medium leads
RNFCL		Flanged Circular	End cap type	High helix lead Ultra high helix lead

- Short delivery time: R Series is standardized, and available in stock.
- Interchangeable screw shaft and ball nut: Screw shaft and nut assembly components are sold separately, and randomly-matched. The maximum axial play after assembly is shown in the dimension tables.
- Low prices: Screw shaft is processed by rolling. This is why prices are lower than those of precision types.
- Abundant series: There are 128 types of nut assembly combinations in the series. Each combination has two to three different lengths in screw shaft.

### Reference number

**Nut assembly (example)**

**R N F T L 25 10 A 5 S**

Product code (rolled nut)					
Nut model FTL, FBL, STL, CT, FCL	Screw shaft diameter (mm)				Seal code S: With seal No code: Without seal
					Effective turns of balls (turns of balls x circuit number)
					Internal design code
					Lead (mm)

**Screw shaft (example)**

**R S 25 10 A 20**

Product code (Rolled screw shaft)					
Screw shaft diameter (mm)					Screw shaft length (x 100 mm)
					Internal design code
					Lead (mm)

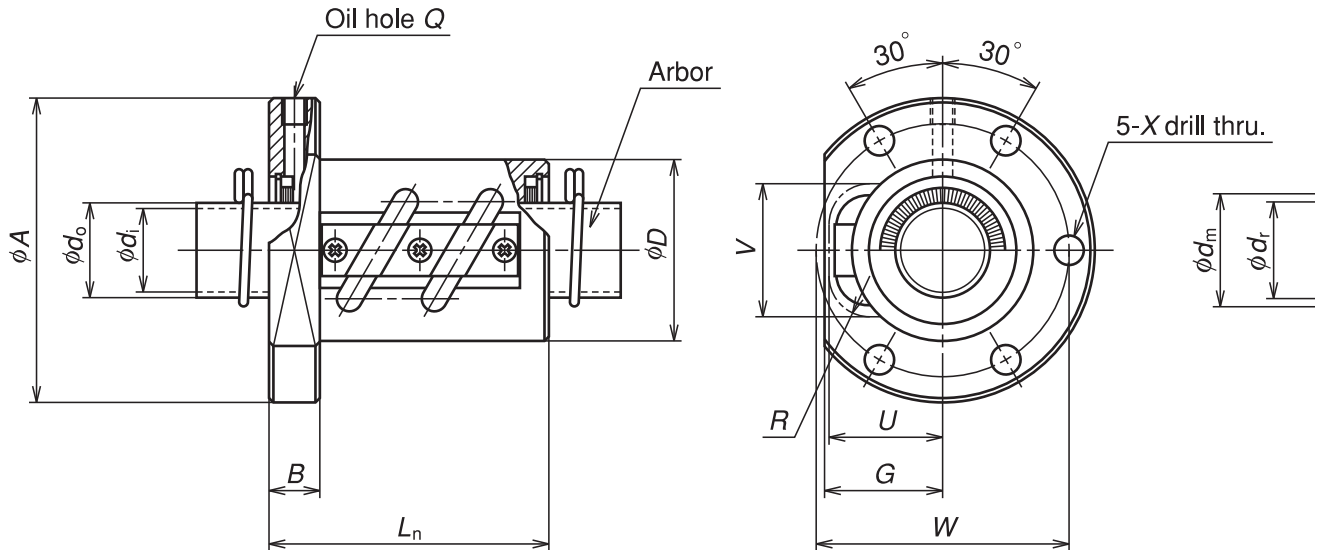

Ball nut No.	Shaft dia. $d$	Lead $l$	Ball dia. $D_w$	Ball circle dia. $d_m$	Root dia. $d_r$	Effective turns of balls Turns $\times$ Circuits	Basic load rating		Axial plax Max.	
							N			
							Dynamic $C_a$	Static $C_{0a}$		
<b>RNFTL 1003A3.5</b>	10	3	2.381	10.65	8.0	3.5 $\times$ 1	3780	6730	0.10	
<b>RNFTL 1006A2.5S</b>	10	6	2.381	10.65	8.1	2.5 $\times$ 1	2830	4810	0.10	
<b>RNFTL 1208A2.5S</b>	12	8	2.778	12.65	9.6	2.5 $\times$ 1	3730	6560	0.10	
<b>RNFTL 1404A3.5S</b>	14	4	2.778	14.5	11.5	3.5 $\times$ 1	5370	10800	0.10	
<b>RNFTL 1405A2.5S</b>	14	5	3.175	14.5	11.0	2.5 $\times$ 1	5260	9720	0.10	
<b>RNFTL 1610A2.5</b>	16	10	3.175	16.75	13.3	2.5 $\times$ 1	5660	11500	0.10	
<b>RNFTL 1610A2.5S</b>										
<b>RNFTL 1808A3.5</b>	18	8	4.762	18.5	13.6	3.5 $\times$ 1	13200	25800	0.15	
<b>RNFTL 1808A3.5S</b>										
<b>RNFTL 2005A2.5</b>	20	5	3.175	20.5	17.0	2.5 $\times$ 1	6360	14200	0.10	
<b>RNFTL 2005A2.5S</b>										
<b>RNFTL 2010A2.5</b>	20	10	4.762	21.25	16.2	2.5 $\times$ 1	10900	21800	0.15	
<b>RNFTL 2010A2.5S</b>										
<b>RNFTL 2505A5</b>	25	5	3.175	25.5	22.0	2.5 $\times$ 2	12800	36300	0.10	
<b>RNFTL 2505A5S</b>										
<b>RNFTL 2510A2.5</b>	25	10	6.35	26	19.	2.5 $\times$ 1	17500	35200	0.20	
<b>RNFTL 2510A2.5S</b>										
<b>RNFTL 2510A5</b>										
<b>RNFTL 2510A5S</b>						2.5 $\times$ 2	31800	70300		

- Remarks
1. Protruding portion of the tube does not have any interference with the ball nut housing if its dimensions corresponding to U and V are large enough.
  2. The actual entire screw shaft length may become slightly longer than nominal length Ls due to manufacturing tolerance.
  3. Seal is contained in the nut. Therefore, the external dimensions of those with a seal are the same as those without. In the side view drawing of ball nut, the above of the center line is with seal, and beneath is without seal. Seal for those with the shaft diameter of 14 mm or less is made of synthetic resin. Seal for those of 16 mm or over is a "Brush-seal."

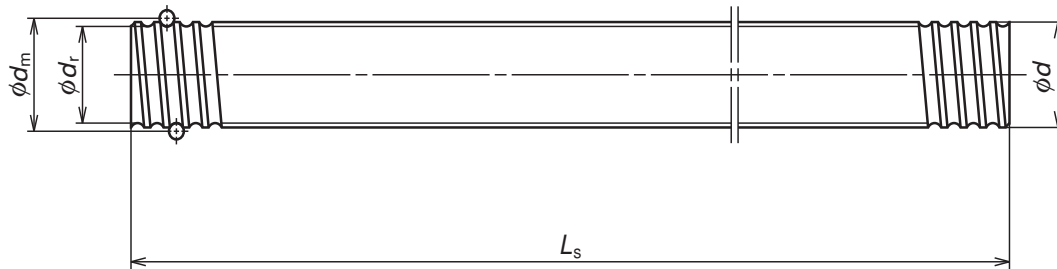

Unit: mm

Outside dia.	Ball nut dimensions										Arbor		Screw shaft			Screw shaft No.
	Flange			Length	Bolt hole		Oil hole		Projecting tube			Outside dia.	Bore	Standard length		
$D$	$A$	$G$	$B$	$L_n$	$W$	$X$	$Q$	$U$	$V$	$R$	$d_o$	$d$	$L_s$			
20	40	15	6	34	30	4.5	M3×0.5	15	15	7	8.1	6.1	400	800	RS1003A**	
20	40	15	6	36	30	4.5	M3×0.5	15	15	5	8.1	6.1	400	800	RS1006A**	
25	45	19	8	46	35	4.5	M3×0.5	19	18	7	9.6	7.6	400	800	RS1208A**	
25	50	19	10	43	40	4.5	M6×1	19	20	7	11.5	9.5	500	1000	RS1404A**	
30	50	22	10	45	40	4.5	M6×1	22	21	8	11.0	9.0	500	1000	RS1405A**	
30	53	23	10	54	41	5.5	M6×1	23	22.5	8	13.3	11.3	500	1000	1500	RS1610A**
34	63	27	12	58	49	6.6	M6×1	27	27	14	13.6	11.6	500	1000	1500	RS1808A**
40	60	28	10	46	50	4.5	M6×1	28	27	10	17.0	14.6	500	1000	2000	RS2005A**
40	67	30	12	59	53	6.6	M6×1	30	29	12	16.2	13.8	500	1000	2000	RS2010A**
42	71	28	12	66	57	6.6	M6×1	28	31	10	22.0	19.6	1000	2000	2500	RS2505A**
44	80	34	15	62	62	9	M6×1	34	37	17	19.0	16.6	1000	2000	2500	RS2510A**
44	80	34	15	92	62	9	M6×1	34	37	17						

Remarks 4. Nut assembly with arbor and the screw shaft are separated at time of delivery.

5. At the end of the screw shaft reference number where marked with "\*\*", fill with the value obtained by dividing the standard screw shaft length by 100 mm.

6. Items in stock are not applied surface treatment. NSK provides treatment such as phosphate coating on request.



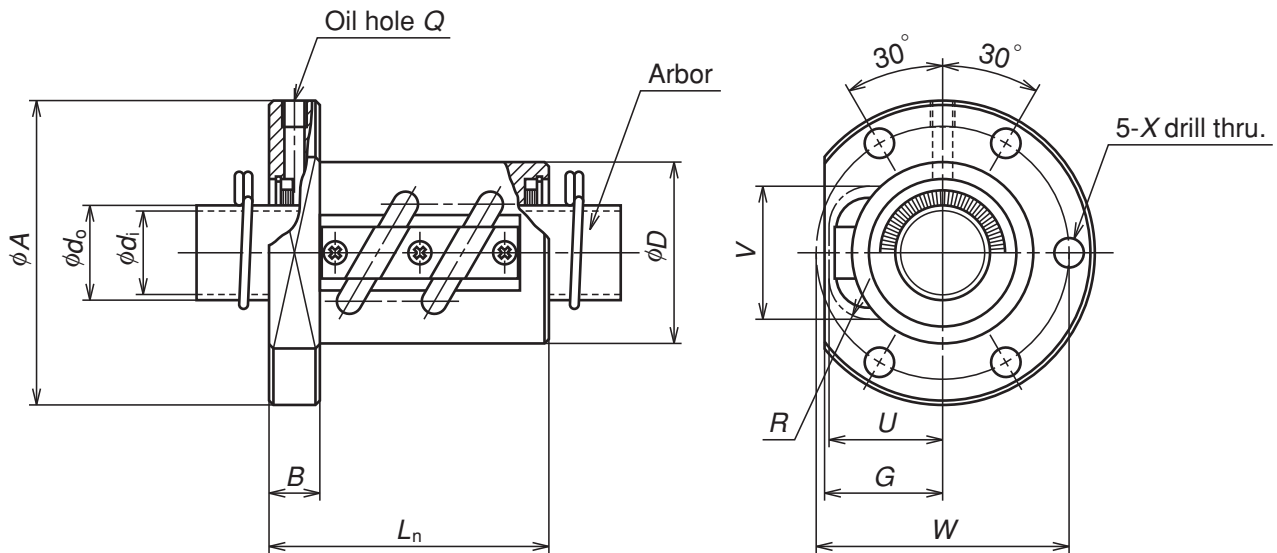

Ball nut No.	Shaft dia. $d$	Lead $l$	Ball dia. $D_w$	Ball circle dia. $d_m$	Root dia. $d_r$	Effective turns of balls Turns × Circuits	Basic load rating		Axial play Max.
							N		
							Dynamic $C_s$	Static $C_{0s}$	
<b>RNFTL 2806A2.5</b> <b>RNFTL 2806A2.5S</b>	28	6	3.175	28.5	25.0	2.5×1	7430	20300	0.10
<b>RNFTL 2806A5</b> <b>RNFTL 2806A5S</b>						2.5×2	13500	40600	
<b>RNFTL 3210A5</b> <b>RNFTL 3210A5S</b>	32	10	6.35	33.75	27.0	2.5×2	35700	92200	0.20
<b>RNFTL 3610A2.5</b> <b>RNFTL 3610A2.5S</b>	36	10	6.35	37	30.	2.5×1	21000	51000	0.20
<b>RNFTL 3610A5</b> <b>RNFTL 3610A5S</b>						2.5×2	38100	102000	
<b>RNFTL 4010A7</b> <b>RNFTL 4010A7S</b>	40	10	6.35	41.75	35.0	3.5×2	53500	164000	0.20
<b>RNFTL 4512A5</b> <b>RNFTL 4512A5S</b>	45	12	7.144	46.5	39.0	2.5×2	49600	147000	0.23
<b>RNFTL 5010A7</b> <b>RNFTL 5010A7S</b>	50	10	6.35	51.75	45.0	3.5×2	59500	205000	0.20
<b>RNFTL 5016A5</b> <b>RNFTL 5016A5S</b>	50	16	9.525	52	42.0	2.5×2	99900	293000	0.23

- Remarks
1. The protruding portion of the tube does not interfere with nut housing if its corresponding dimensions to U and V are large enough.
  2. The actual screw shaft length may become slightly longer than nominal length of  $L_s$  due to manufacturing tolerance.
  3. The seal is contained in the nut. Therefore, the external dimensions of those with a seal are the same as those without.
- In the side view drawing of the nut, the above of the center line is with seal, and beneath is without seal.  
Seal is "Brush-seal".

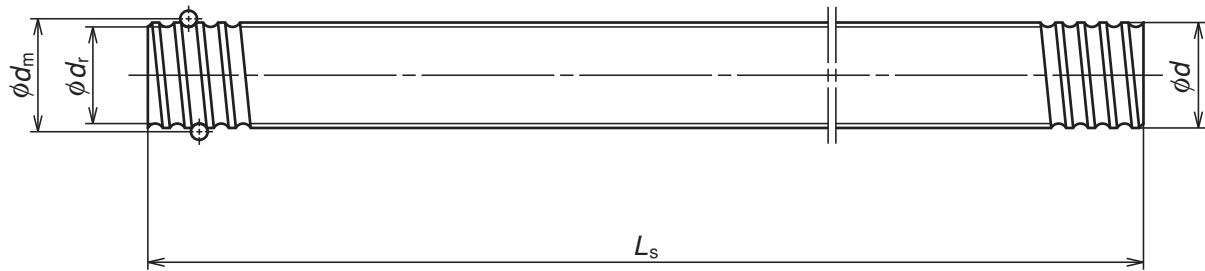

Unit: mm

Ball nut dimensions											Arbor		Screw shaft			Screw shaft No.
Outside dia.	Flange			Length	Bolt hole		Oil hole	Projecting tube			Outside dia.	Bore	Standard length			
$D$	$A$	$G$	$B$	$L_n$	$W$	$X$	$Q$	$U$	$V$	$R$	$d_o$	$d_i$	$L_s$			
50	79	33	15	55	65	6.6	M6×1	33	34	10	25.0	22.6	1000	2000	2500	RS2806A**
50	79	33	15	79	65	6.6	M6×1	33	34	10			1000	2000	2500	
55	97	39	18	97	75	11	M6×1	39	42	17	27.0	24.6	1000	2000	3000	RS3210A**
60	102	42	18	68	80	11	M6×1	42	46	17	30.0	27.6	1000	2000	3000	RS3610A**
60	102	42	18	98	80	11	M6×1	42	46	17			1000	2000	3000	
65	114	44	20	120	90	14	M6×1	44	50	20	35.0	31.8	2000	3000	4000	RS4010A**
70	130	47	22	116	100	18	M6×1	47	55	20	39.0	35.8	2000	3000	4000	RS4512A**
80	140	52	22	122	110	18	M6×1	52	59	20	45.0	41.8	2000	3000	4000	RS5010A**
85	163	57	28	146	125	22	M6×1	57	63	25	42.0	38.8	2000	3000	4000	RS5016A**

- Remarks
- Nut assembly with arbor and the screw shaft are separated at time of delivery.
  - At the end of the screw shaft reference number where marked with "\*\*", fill with the value obtained by dividing the standard screw shaft length by 100 mm.
  - Items in stock are not applied surface treatment. NSK provides treatment such as phosphate coating on request.

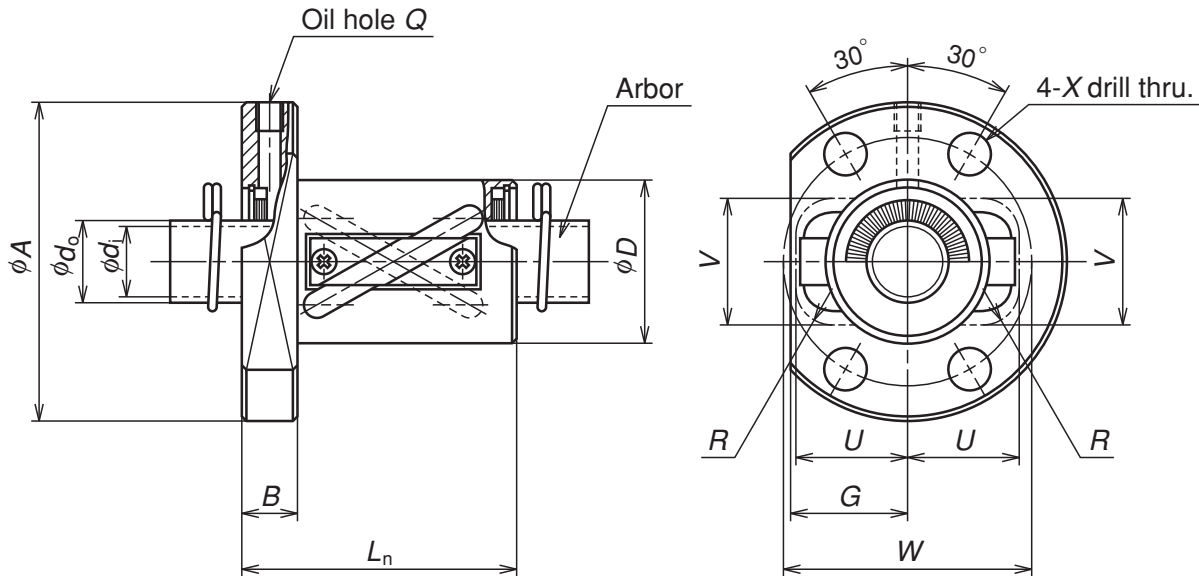

Ball nut No.	Shaft dia. $d$	Lead $l$	Ball dia. $D_w$	Ball circle dia. $d_m$	Root dia. $d_r$	Effective turns of balls Turns × Circuits	Basic load rating		Axial play Max.
							(N)		
							Dynamic $C_d$	Static $C_{0a}$	
<b>RNFTL 1212A3</b>	12	12	2.381	12.65	10.1	1.5 × 2	3360	6270	0.10
<b>RNFTL 1616A3</b> <b>RNFTL 1616A3S</b>	16	16	2.778	16.65	13.6	1.5 × 2	4880	9650	0.10
<b>RNFTL 2020A3</b> <b>RNFTL 2020A3S</b>	20	20	3.175	20.75	17.3	1.5 × 2	7010	15400	0.10
<b>RNFTL 2525A3</b> <b>RNFTL 2525A3S</b>	25	25	3.969	26	22.0	1.5 × 2	10500	24100	0.12
<b>RNFTL 3232A3</b> <b>RNFTL 3232A3S</b>	32	32	4.762	33.25	28.0	1.5 × 2	15300	37100	0.15
<b>RNFTL 4040A3</b> <b>RNFTL 4040A3S</b>	40	40	6.35	41.75	35.0	1.5 × 2	24400	61600	0.20

- Remarks
1. Protruding portion of the tube does not have any interference with the ball nut housing if its dimensions corresponding to  $U$  and  $V$  are large enough.
  2. The actual entire screw shaft length may become slightly longer than nominal length  $L_s$  due to manufacturing tolerance.
  3. Seal is contained in the nut. Therefore, the external dimensions of those with a seal are the same as those without. In the side view drawing of ball nut, the above of the center line is with seal, and beneath is without seal. Seal for those with the shaft diameter of 14 mm or less is made of synthetic resin. Seal for those of 16 mm or over is a "Brush-seal."

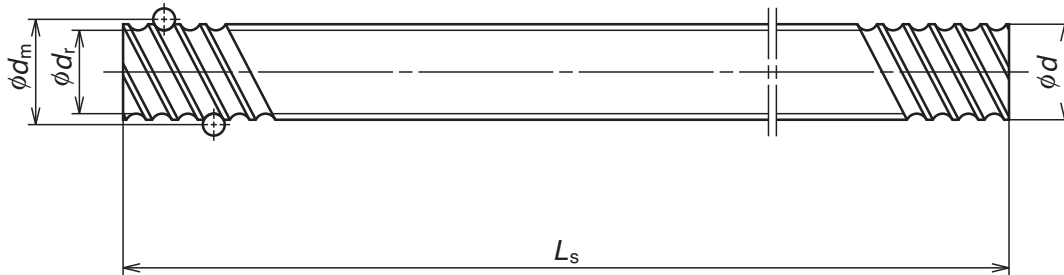

Unit: mm

Ball nut dimensions											Arbor		Screw shaft			Screw shaft No.
Outside dia.	Flange			Length	Bolt hole		Oil hole	Projecting tube			Outside dia.	Bore	Standard length			
$D$	$A$	$G$	$B$	$L_n$	$W$	$X$	$Q$	$U$	$V$	$R$	$d_o$	$d_i$	$L_s$			
24	44	17	8	44	34	4.5	M3 × 0.5	17	16	5	10.1	8.1	400	800	RS1212A**	
30	55	22	10	50	43	6.6	M6 × 1	22	22	7	13.6	11.6	500	1000	1500	RS1616A**
35	68	25	12	59	52	9	M6 × 1	25	27	8	17.3	14.9	500	1000	2000	RS2020A**
45	80	31	12	69	63	9	M6 × 1	31	32	10	22.0	19.6	1000	2000	2500	RS2525A**
55	100	37	15	84	80	11	M6 × 1	37	40	12	28.0	25.6	1000	2000	3000	RS3232A**
70	120	46	18	103	95	14	M6 × 1	46	49	15	35.0	31.8	2000	3000	4000	RS4040A**

Remarks 4. Nut assembly with arbor and the screw shaft are separated at time of delivery.

5. At the end of the screw shaft reference number where marked with "\*\*", fill with the value obtained by dividing the standard screw shaft length by 100 mm.

6. Items in stock are not applied surface treatment. NSK provides treatment such as phosphate coating on request.



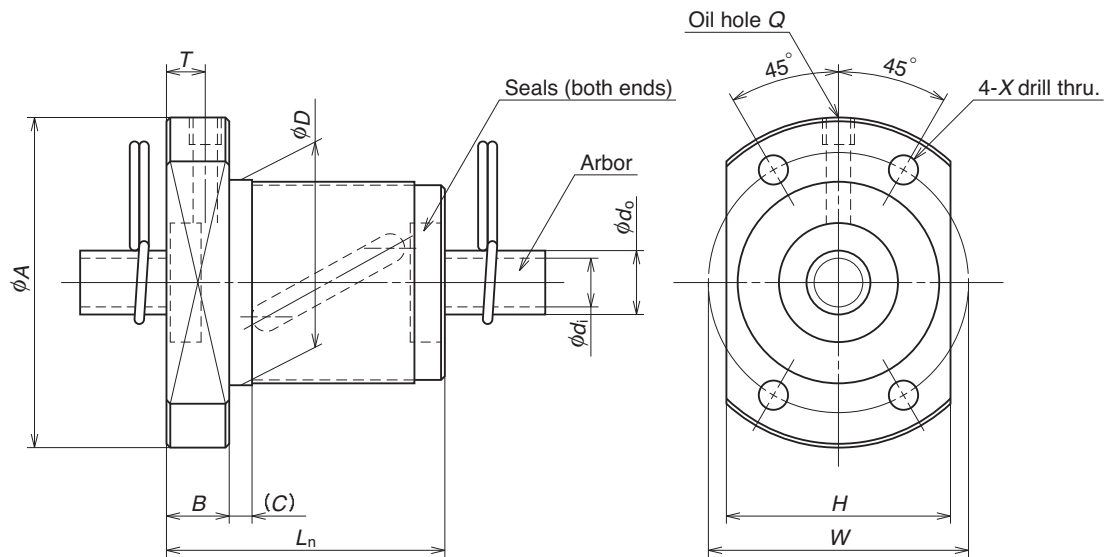

Ball nut No.	Shaft dia. $d$	Lead $l$	Ball dia. $D_w$	Ball circle dia. $d_m$	Root dia. $d$	Effective turns of balls Turns × Circuits	Basic load rating (N)		Axial play Max.
							Dynamic $C_d$	Static $C_{0a}$	
<b>RNFBL 1006A2.5S</b>	10	6	2.381	10.65	8.1	2.5×1	2830	4810	0.10
<b>RNFBL 1208A2.5S</b>	12	8	2.778	12.65	9.6	2.5×1	3730	6560	0.10
<b>RNFBL 1404A3.5S</b>	14	4	2.778	14.5	11.5	3.5×1	5370	10800	0.10
<b>RNFBL 1405A2.5S</b>	14	5	3.175	14.5	11.0	2.5×1	5260	9720	0.10
<b>RNFBL 1808A3.5S</b>	18	8	4.762	18.5	13.6	3.5×1	13200	25800	0.15
<b>RNFBL 2005A2.5S</b>	20	5	3.175	20.5	17.0	2.5×1	6360	14200	0.10
<b>RNFBL 2010A2.5S</b>	20	10	4.762	21.25	16.2	2.5×1	10900	21800	0.15
<b>RNFBL 2505A2.5S</b>	25	5	3.175	25.5	22.0	2.5×1	7070	18200	0.10
<b>RNFBL 2505A5S</b>						2.5×2	12800	36300	
<b>RNFBL 2510A2.5S</b>	25	10	6.35	26	19.0	2.5×1	17500	35200	0.20
<b>RNFBL 2510A5S</b>						2.5×2	31800	70300	
<b>RNFBL 2806A2.5S</b>	28	6	3.175	28.5	25.0	2.5×1	7430	20300	0.10
<b>RNFBL 2806A5S</b>						2.5×2	13500	40600	
<b>RNFBL 3210A2.5S</b>	32	10	6.35	33.75	27.0	2.5×1	19700	46100	0.20
<b>RNFBL 3210A5S</b>						2.5×2	35700	92200	
<b>RNFBL 3610A2.5S</b>	36	10	6.35	37	30.0	2.5×1	21000	51000	0.20
<b>RNFBL 3610A5S</b>						2.5×2	38100	102000	
<b>RNFBL 4010A5S</b>	40	10	6.35	41.75	35.0	2.5×2	40100	116000	0.20

- Remarks
1. The actual screw shaft length may be slightly longer than nominal length  $L_s$  due to manufacturing tolerance.
  2. Nut assembly with arbor and screw shaft are separated at time of delivery.
  3. The value obtained by dividing the standard screw length by 100 mm will be entered at the end of the reference number where marked with " \* \* ."

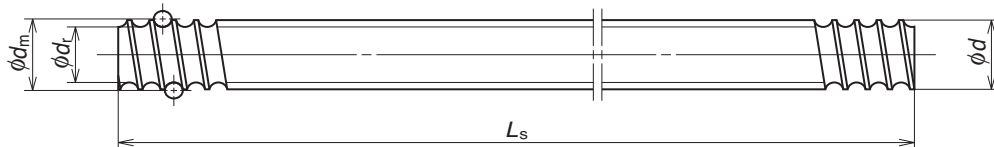

Unit: mm

Ball nut dimensions										Arbor		Screw shaft			Screw shaft No.
Outside dia. <i>D</i>	Flange			Length		Bolt hole		Oil hole		Outside dia. <i>d<sub>o</sub></i>	Bore <i>d<sub>i</sub></i>	Standard length <i>L<sub>s</sub></i>			
	<i>A</i>	<i>H</i>	<i>B</i>	Overall length <i>L</i>	( <i>C</i> )	<i>W</i>	<i>X</i>	<i>Q</i>	<i>T</i>						
26	42	29	8	36	3	34	4.5	M3×0.5	5.0	8.1	6.1	400	800		RS1006A**
29	45	32	8	44	3	37	4.5	M3×0.5	5.5	9.6	7.6	400	800		RS1208A**
31	50	37	10	40	4	40	4.5	M6×1	5.0	11.5	9.5	500	1000		RS1404A**
32	50	38	10	40	4	40	4.5	M6×1	5.0	11.0	9.0	500	1000		RS1405A**
50	80	60	12	61	4	65	6.6	M6×1	6.0	13.6	11.6	500	1000	1500	RS1808A**
40	60	46	10	40	4	50	4.5	M6×1	5.0	17.0	14.6	500	1000	2000	RS2005A**
52	82	64	12	61	5	67	6.6	M6×1	6.0	16.2	13.8	500	1000	2000	RS2010A**
43	67	50	10	40	4	55	5.5	M6×1	5.0	22.0	19.6	1000	2000	2500	RS2505A**
				55											
60	96	72	15	66	5	78	9.0	M6×1	7.5	19.0	16.6	1000	2000	2500	RS2510A**
				96											
50	80	60	12	47	5	65	6.6	M6×1	6.0	25.0	22.6	1000	2000	2500	RS2806A**
				65											
67	103	78	15	67	5	85	9.0	M6×1	7.5	27.0	24.6	1000	2000	3000	RS3210A**
				97											
70	110	82	17	69	5	90	11.0	M6×1	8.5	30.0	27.6	1000	2000	3000	RS3610A**
				99											
76	116	88	17	99	5	96	11.0	M6×1	8.5	35.0	31.8	2000	3000	4000	RS4010A**

Remarks 4. Items in stock are not applied surface treatment. NSK provides treatment such as phosphate coating on request.  
5. Seal for those with the shaft diameter of 14 mm or less is made of synthetic resin. Seal for those with 16 mm or larger is "Brush-seal."

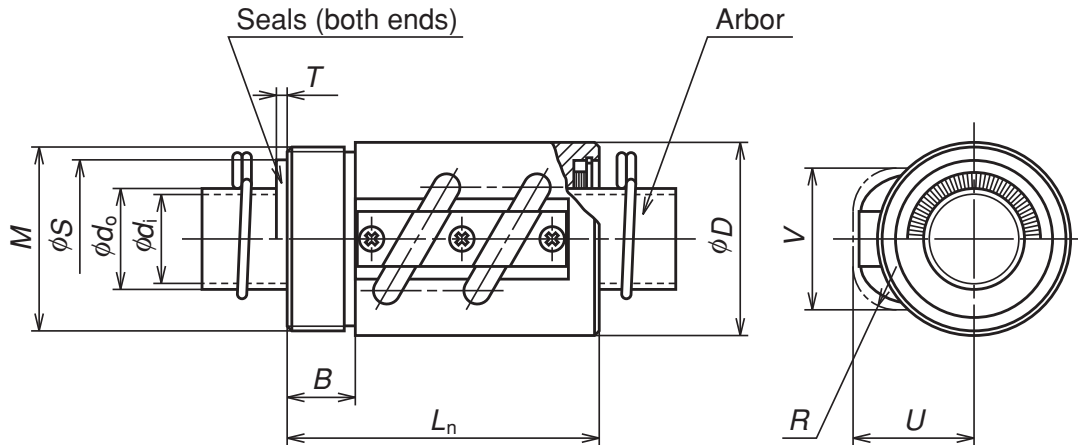

Ball nut No	Shaft dia. $d$	Lead $l$	Ball dia. $D_w$	Ball circle dia. $d_m$	Root dia. $d_r$	Effective turns of balls Turns × Circuits	Basic load rating (N)		Axial play Max.
							Dynamic $C_a$	Static $C_{0a}$	
<b>RNCT 1003A3.5</b>	10	3	2.381	10.65	8.0	3.5 × 1	3780	6730	0.10
<b>RNCT 1404A3.5S</b>	14	4	2.778	14.5	11.5	3.5 × 1	5370	10800	0.10
<b>RNCT 1405A2.5S</b>	14	5	3.175	14.5	11.0	2.5 × 1	5260	9720	0.10
<b>RNCT 1808A3.5</b>	18	8	4.762	18.5	13.6	3.5 × 1	13200	25800	0.15
<b>RNCT 1808A3.5S</b>									
<b>RNCT 2005A2.5</b>	20	5	3.175	20.5	17.0	2.5 × 1	6360	14200	0.10
<b>RNCT 2005A2.5S</b>									
<b>RNCT 2505A5</b>	25	5	3.175	25.5	22.0	2.5 × 2	12800	36300	0.10
<b>RNCT 2505A5S</b>									
<b>RNCT 2510A5</b>	25	10	6.35	26	19.0	2.5 × 2	31800	70300	0.20
<b>RNCT 2510A5S</b>									
<b>RNCT 2806A5</b>	28	6	3.175	28.5	25.0	2.5 × 2	13500	40600	0.10
<b>RNCT 2806A5S</b>									
<b>RNCT 3210A5</b>	32	10	6.35	33.75	27.0	2.5 × 2	35700	92200	0.20
<b>RNCT 3210A5S</b>									
<b>RNCT 3610A5</b>	36	10	6.35	37	30.0	2.5 × 2	38100	102000	0.20
<b>RNCT 3610A5S</b>									
<b>RNCT 4010A7</b>	40	10	6.35	41.75	35.0	3.5 × 2	53500	164000	0.20
<b>RNCT 4010A7S</b>									
<b>RNCT 4512A5</b>	45	12	7.144	46.5	39.0	2.5 × 2	49600	147000	0.23
<b>RNCT 4512A5S</b>									
<b>RNCT 5010A7</b>	50	10	6.35	51.75	45.0	3.5 × 2	59500	205000	0.20
<b>RNCT 5010A7S</b>									
<b>RNCT 5016A5</b>	50	16	9.525	52	42.0	2.5 × 2	99900	293000	0.23
<b>RNCT 5016A5S</b>									

- Remarks
1. Protruding portion of the tube does not have any interference with the ball nut housing if its dimensions corresponding to U and V are large enough.
  2. The actual entire screw shaft length may become slightly longer than nominal length  $L_s$  due to manufacturing tolerance.
  3. A seal cannot be installed in the V thread side. It may be installed in the opposite side.  
Seal is contained in the nut. Therefore, the external dimensions of those with a seal are the same as those without. In the side view drawing of ball nut, the above of the center line is with seal, and beneath is without seal.

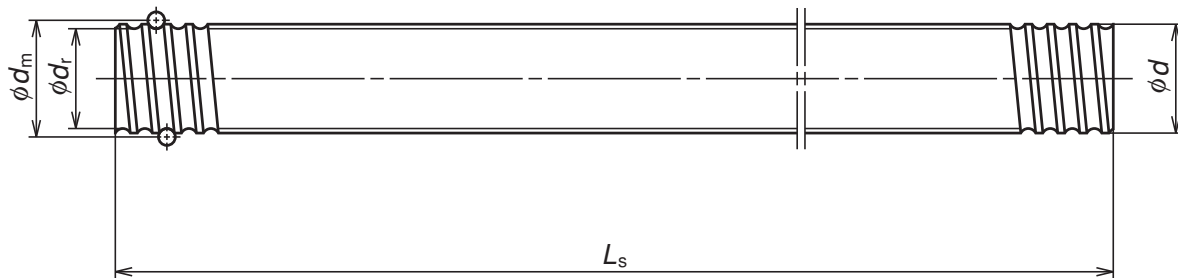

Unit: mm

Ball nut dimensions							Seal dimensions		Arbor		Screw shaft			Screw shaft No.
Outside dia.	Flange		Length	Projecting tube			Diameter	Thickness	Outside dia.	Bore	Standard length			
$D$	$M$	$B$	$L_n$	$U$	$V$	$R$	$S$	$T$	$d_o$	$d_i$	$L_s$			
20	M18×1	10	38	15	15	7			8.1	6.1	400	800		RS1003A**
25	M24×1	10	43	19	20	7			11.5	9.5	500	1000		RS1404A**
30	M26×1.5	10	45	22	21	8			11.0	9.0	500	1000		RS1405A**
34	M32×1.5	12	58	27	27	14	28.5	2.5	13.6	11.6	500	1000	1500	RS1808A**
40	M36×1.5	12	48	28	27	10	29.5	2.5	17.0	14.6	500	1000	2000	RS2005A**
42	M40×1.5	15	69	28	31	10	34.5	2.5	22.0	19.6	1000	2000	2500	RS2505A**
44	M42×1.5	15	92	34	37	17	38.5	2.5	19.0	16.6	1000	2000	2500	RS2510A**
50	M45×1.5	15	79	33	34	10	37.5	2.5	25.0	22.6	1000	2000	2500	RS2806A**
55	M50×1.5	18	97	39	42	17	45.5	2.5	27.0	24.6	1000	2000	3000	RS3210A**
60	M55×2	18	98	42	46	17	50.5	3.0	30.0	27.6	1000	2000	3000	RS3610A**
65	M60×2	20	125	44	50	20	54.5	3.0	35.0	31.8	2000	3000	4000	RS4010A**
70	M65×2	30	124	47	55	20	60.5	3.0	39.0	35.8	2000	3000	4000	RS4512A**
80	M75×2	40	140	52	59	20	64.5	3.0	45.0	41.8	2000	3000	4000	RS5010A**
85	M80×2	40	158	57	63	25	68.5	3.0	42.0	38.8	2000	3000	4000	RS5016A**

Seal for those with the shaft diameter of 14 mm or less is made of synthetic resin. Seal for those of 16 mm or over is a "Brush-seal."

There is no seal on the V-thread side for RNCT1404A3.5S and RNCT1405A2.5S

- Nut assembly with arbor and the screw shaft are separated at time of delivery.
- At the end of the screw shaft reference number where marked with "\*\*", fill with the value obtained by dividing the standard screw shaft length by 100 mm.
- Items in stock are not applied surface treatment. NSK provides treatment such as phosphate coating on request.



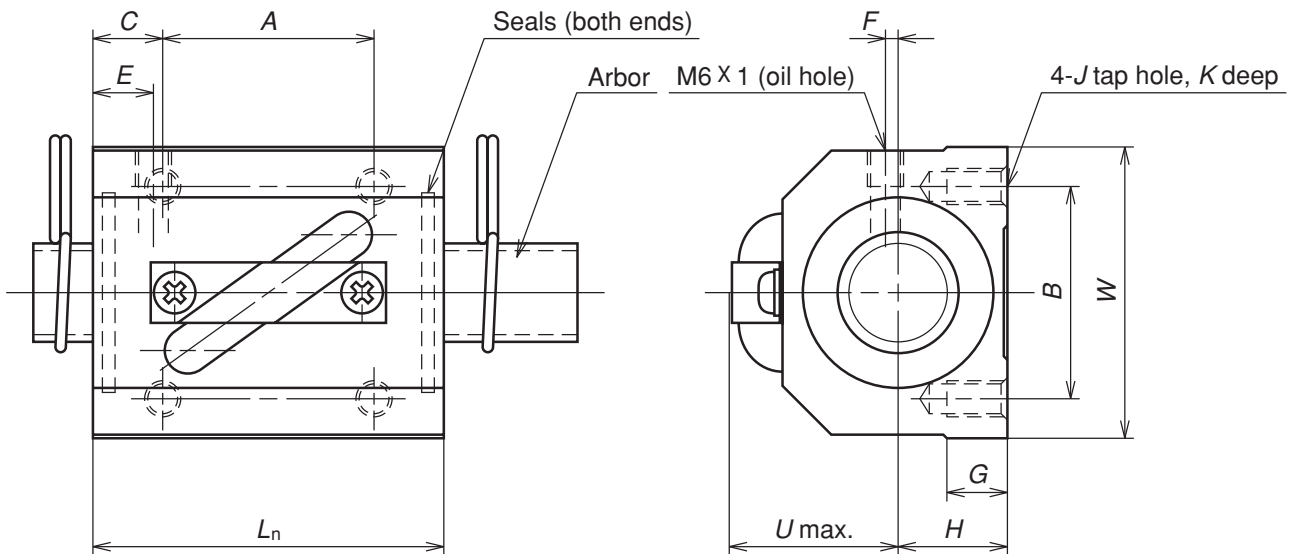

Ball nut No.	Shaft dia. $d$	Lead $l$	Ball dia. $D_w$	Ball circle dia. $d_m$	Root dia. $d_r$	Effective turns of balls Turns $\times$ Circuits	Basic load rating (N)		Axial play Max.
							Dynamic $C_e$	Static $C_{0a}$	
<b>RNSTL 1404A3.5S</b>	14	4	2.778	14.5	11.5	3.5 $\times$ 1	5370	10800	0.10
<b>RNSTL 1405A2.5S</b>	14	5	3.175	14.5	11.0	2.5 $\times$ 1	5260	9720	0.10
<b>RNSTL 1808A3.5S</b>	18	8	4.762	18.5	13.6	3.5 $\times$ 1	13200	25800	0.15
<b>RNSTL 2005A2.5S</b>	20	5	3.175	20.5	17.0	2.5 $\times$ 1	6360	14200	0.10
<b>RNSTL 2010A2.5S</b>	20	10	4.762	21.25	16.2	2.5 $\times$ 1	10900	21800	0.15
<b>RNSTL 2505A2.5S</b>	25	5	3.175	25.5	22.0	2.5 $\times$ 1	7070	18200	0.10
<b>RNSTL 2510A5S</b>	25	10	6.35	26	19.0	2.5 $\times$ 1	31800	70300	0.20
<b>RNSTL 2806A2.5S</b>	28	6	3.175	28.5	25.0	2.5 $\times$ 1	7430	20300	0.10
<b>RNSTL 2806A5S</b>						2.5 $\times$ 2	13500	40600	
<b>RNSTL 3210A2.5S</b>	32	10	6.35	33.75	27.0	2.5 $\times$ 1	19700	46100	0.20
<b>RNSTL 3210A5S</b>						2.5 $\times$ 2	35700	92200	
<b>RNSTL 3610A2.5S</b>	36	10	6.35	37	30.0	2.5 $\times$ 1	21000	51000	0.20
<b>RNSTL 3610A5S</b>						2.5 $\times$ 2	38100	102000	
<b>RNSTL 4512A2.5S</b>	45	12	7.144	46.5	39.0	2.5 $\times$ 2	49600	147000	0.23

- Remarks
1. The actual screw shaft length may be slightly longer than nominal length  $L_s$  due to manufacturing tolerance.
  2. Nut assembly with arbor and screw shaft are separated at time of delivery.
  3. The value obtained by dividing the standard screw length by 100 mm will be entered at the end of the reference number where marked with " \* \* ".

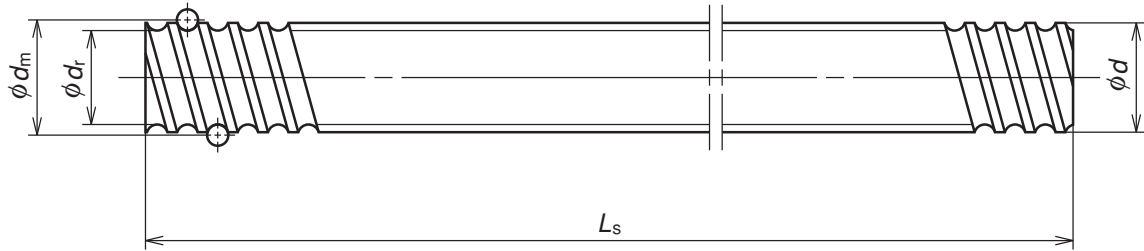

Unit: mm

Ball nut dimensions											Arbor		Screw shaft			Screw shaft No.
Length	Width	Center height	Bolt hole				Oil hole			Outside dia.	Bore	Standard length				
$L_n$	$W$	$H$	$A$	$B$	$C$	$J$	$K$	$E$	$F$	$U$	$d_o$	$d_i$	$L_s$			
38	34	13	22	26	8	M4	7	7	3	20	11.5	9.5	500	1000		RS1404A**
38	34	13	22	26	10.5	M4	7	7	3	21	11.0	9.0	500	1000		RS1405A**
56	48	17	35	35	11	M6	10	8	3	26	13.6	11.6	500	1000	1500	RS1808A**
38	48	17	22	35	8	M6	9	6	2	27	17.0	14.6	500	1000	2000	RS2005A**
58	48	18	35	35	11.5	M6	10	10	2	28	16.2	13.8	500	1000	2000	RS2010A**
35	60	20	22	40	6.5	M8	10	6	0	27	22.0	19.6	1000	2000	2500	RS2505A**
94	60	23	60	40	17	M8	12	10	0	32	19.0	16.6	1000	2000	2500	RS2510A**
42	60	22	18	40	12	M8	12	8	0	32	25.0	22.6	1000	2000	2500	RS2806A**
67	60	22	40	40	13.5											
64	70	26	45	50	9.5	M8	12	10	0	38	27.0	24.6	1000	2000	3000	RS3210A**
94	70	26	60	50	17											
64	86	29	45	60	9.5	M10	16	11	0	41	30.0	27.6	1000	2000	3000	RS3610A**
96	86	29	60	60	18											
115	100	36	75	75	20	M12	20	13	0	46	39.0	35.8	2000	3000	4000	RS4510A**

- Remarks 4. Items in stock are not applied surface treatment. NSK provides treatment such as phosphate coating on request.  
 5. Seal for those with the shaft diameter of 14 mm or less is made of synthetic resin. Seal for those with 18 mm or larger is "Brush-seal."

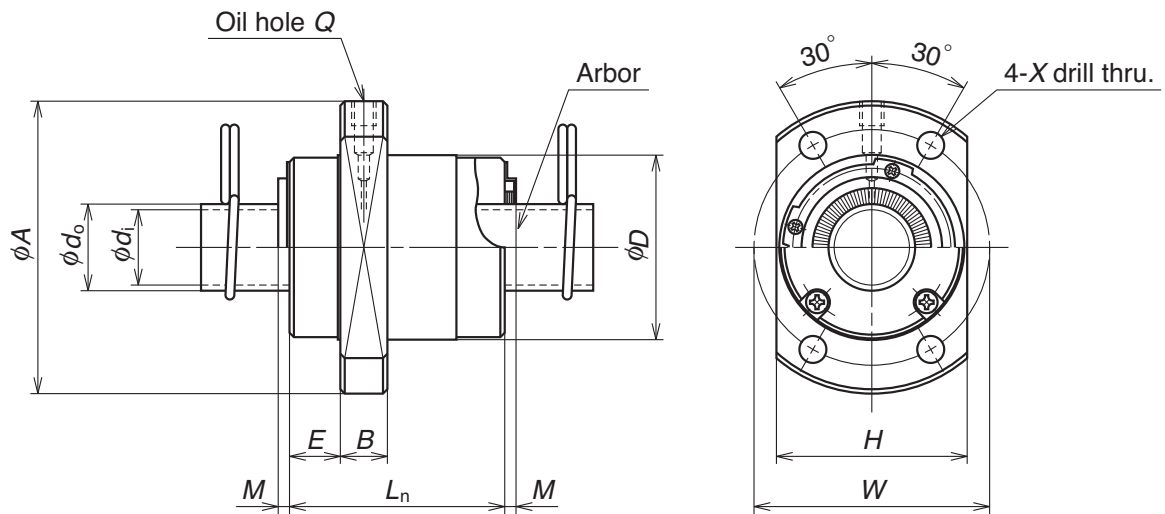

Ball nut No.	Shaft dia. $d$	Lead $l$	Ball dia. $D_w$	Ball circle dia. $d_m$	Root dia. $d_t$	Effective turns of balls Turns $\times$ Circuits	Basic load rating (N)		Axial play Max.
							Dynamic $C_a$	Static $C_{0a}$	
<b>RNFCL 1212A3</b> <b>RNFCL 1212A6</b>	12	12	2.381	12.65	10.1	$1.7 \times 2$ $1.7 \times 4$	3740 6780	6640 13300	0.10
<b>RNFCL 1520A3</b> <b>RNFCL 1520A3S</b>	15	20	3.175	15.5	12.2	$1.7 \times 2$	6730	12300	0.10
<b>RNFCL 1616A3</b> <b>RNFCL 1616A3S</b> <b>RNFCL 1616A6</b> <b>RNFCL 1616A6S</b>	16	16	2.778	16.65	13.5	$1.7 \times 2$ $1.7 \times 4$	5430 9860	10400 20800	0.10
<b>RNFCL 2020A3</b> <b>RNFCL 2020A3S</b> <b>RNFCL 2020A6</b> <b>RNFCL 2020A6S</b>	20	20	3.175	20.75	17.3	$1.7 \times 2$ $1.7 \times 4$	7810 14200	16500 33000	0.10
<b>RNFCL 2525A3</b> <b>RNFCL 2525A3S</b> <b>RNFCL 2525A6</b> <b>RNFCL 2525A6S</b>	25	25	3.969	26	22.0	$1.7 \times 2$ $1.7 \times 4$	11700 21200	25800 51500	0.12
<b>RNFCL 3232A3</b> <b>RNFCL 3232A3S</b> <b>RNFCL 3232A6</b> <b>RNFCL 3232A6S</b>	32	32	4.762	33.25	28.0	$1.7 \times 2$ $1.7 \times 4$	17100 31000	40500 81000	0.15
<b>RNFCL 4040A3</b> <b>RNFCL 4040A3S</b> <b>RNFCL 4040A6</b> <b>RNFCL 4040A6S</b>	40	40	6.35	41.75	35.0	$1.7 \times 2$ $1.7 \times 4$	27200 49300	67900 136000	0.20
<b>RNFCL 5050A3</b> <b>RNFCL 5050A3S</b> <b>RNFCL 5050A6</b> <b>RNFCL 5050A6S</b>	50	50	7.938	52.25	44.0	$1.7 \times 2$ $1.7 \times 4$	40600 73700	106000 212000	0.25

- Remarks
1. The actual screw shaft length may be slightly longer than nominal length  $L_s$  due to manufacturing tolerance.
  2. Nut assembly with arbor and screw shaft are separated at time of delivery.
  3. The value obtained by dividing the standard screw length by 100 mm will be entered at the end of the reference number where marked with " \* \* ."

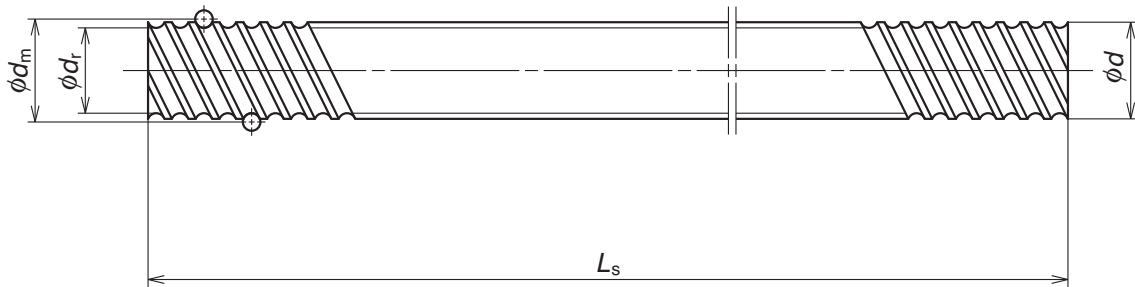

Unit: mm

Outside dia. <i>D</i>	Ball nut dimensions						Arbor		Screw shaft			Screw shaft No.			
	Flange			Length			Bolt hole	Oil hole	Outside dia. <i>d<sub>o</sub></i>	Bore <i>d<sub>i</sub></i>	Standard length <i>L<sub>s</sub></i>				
	<i>A</i>	<i>H</i>	<i>B</i>	<i>E</i>	<i>L<sub>n</sub></i>	<i>M</i>	<i>W</i>	<i>X</i>	<i>Q</i>						
26	44	28	6	9	30	—	35	4.5	M3 × 0.5	10.1	8.1	400	800	RS1212A**	
33	51	35	10	11	45	—	42	4.5	M6 × 1	12.2	10.2	500	1000	1500	RS1520A**
						3									
32	53	34	10	10	38	—	42	4.5	M6 × 1	13.6	11.6	500	1000	1500	RS1616A**
						3									
						—									
						3									
39	62	41	10	11.5	46	—	50	5.5	M6 × 1	17.3	14.9	500	1000	2000	RS2020A**
						3									
						—									
47	74	49	12	13	55	—	60	6.6	M6 × 1	22.0	19.6	1000	2000	2500	RS2525A**
						3									
						—									
58	92	60	12	16	70	—	74	9	M6 × 1	28.0	25.6	1000	2000	3000	RS3232A**
						3									
						—									
73	114	75	15	19.5	85	—	93	11	M6 × 1	35.0	31.8	2000	3000	4000	RS4040A**
						3.5									
						—									
90	135	92	20	21.5	107	—	112	14	M6 × 1	44.0	40.8	2000	3000	4000	RS5050A**
						3.5									
						—									
						3.5									

Remarks 4. Items in stock are not applied surface treatment. NSK provides treatment such as phosphate coating on request.  
5. The entire length of the nut becomes longer by "2 x M " for those with a seal. The seal is "Brush-seal."

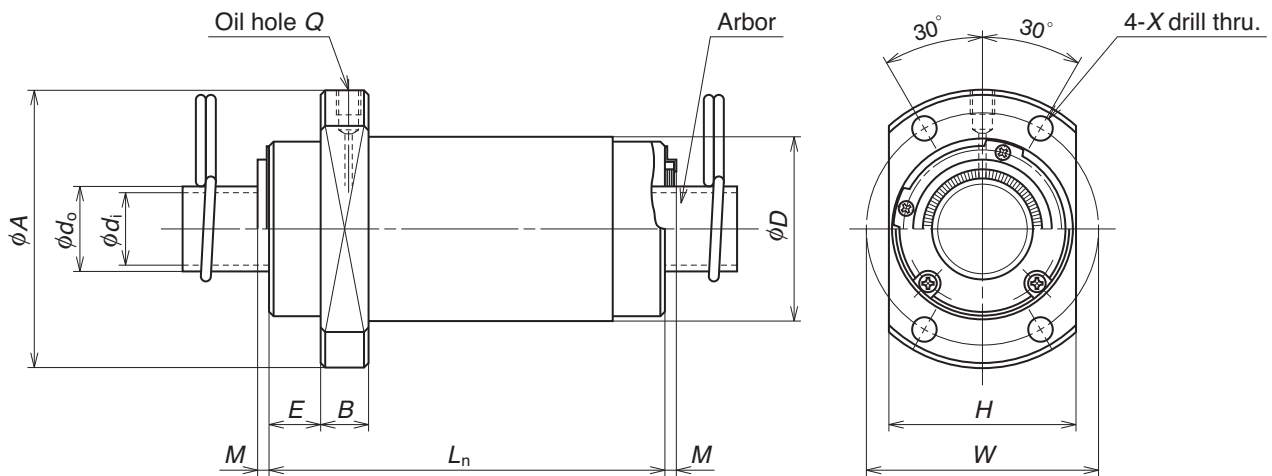

Ball nut No.	Shaft dia. $d$	Lead $l$	Ball dia. $D_w$	Ball circle dia. $d_m$	Root dia. $d$	Effective turns of balls Turns $\times$ Circuits	Basic load rating (N)		Axial play Max.
							Dynamic $C_a$	Static $C_{0a}$	
<b>RNFCL 1632A2</b> <b>RNFCL 1632A2S</b> <b>RNFCL 1632A3</b> <b>RNFCL 1632A3S</b> <b>RNFCL 1632A6</b> <b>RNFCL 1632A6S</b>	16	32	2.778	16.65	13.5	0.7 $\times$ 4	4600	8460	0.10
1.7 $\times$ 2						5430	10400		
1.7 $\times$ 4						9860	20800		
<b>RNFCL 2040A2</b> <b>RNFCL 2040A2S</b> <b>RNFCL 2040A3</b> <b>RNFCL 2040A3S</b> <b>RNFCL 2040A6</b> <b>RNFCL 2040A6S</b>	20	40	3.175	20.75	17.3	0.7 $\times$ 4	6610	13600	0.10
1.7 $\times$ 2						7810	16500		
1.7 $\times$ 4						14200	33000		
<b>RNFCL 2550A2</b> <b>RNFCL 2550A2S</b> <b>RNFCL 2550A3</b> <b>RNFCL 2550A3S</b> <b>RNFCL 2550A6</b> <b>RNFCL 2550A6S</b>	25	50	3.969	26	22.0	0.7 $\times$ 4	9870	21200	0.12
1.7 $\times$ 2						11700	25800		
1.7 $\times$ 4						21200	51500		
<b>RNFCL 3264A3</b> <b>RNFCL 3264A3S</b> <b>RNFCL 3264A6</b> <b>RNFCL 3264A6S</b>	32	64	4.762	33.25	28.0	1.7 $\times$ 2	17100	40500	0.15
1.7 $\times$ 4						31000	81000		
<b>RNFCL 4080A3</b> <b>RNFCL 4080A3S</b> <b>RNFCL 4080A6</b> <b>RNFCL 4080A6S</b>	40	80	6.350	41.75	35.0	1.7 $\times$ 2	27200	67900	0.20
1.7 $\times$ 4						49300	136000		

- Remarks
1. The actual screw shaft length may be slightly longer than nominal length  $L_s$  due to manufacturing tolerance.
  2. Nut assembly with arbor and screw shaft are separated at time of delivery.
  3. The value obtained by dividing the standard screw length by 100 mm will be entered at the end of the reference number where marked with "\*\* \*."

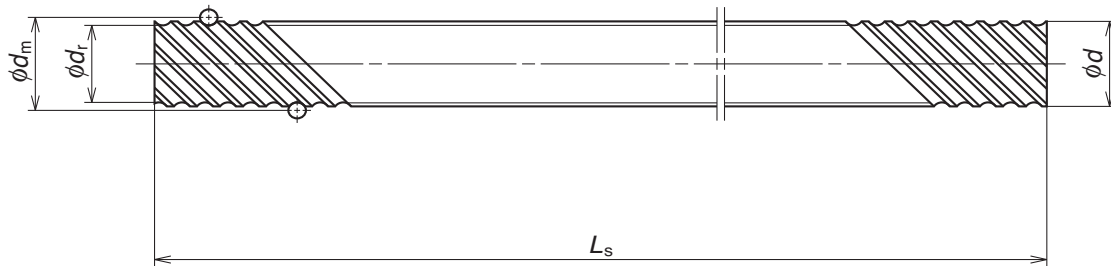

Unit: mm

Ball nut dimensions										Arbor		Screw shaft		Screw shaft No.		
Outside dia.	Flange			Length		Bolt hole		Oil hole	Outside dia.	Bore	Standard length					
$D$	$A$	$H$	$B$	$E$	$L_n$	$M$	$W$	$X$	$Q$	$d_o$	$d_i$	$L_s$				
32	50	34	10	10	34	— 3	41	4.5	M6 × 1	13.5	11.5	500	1000	1500	RS1632A**	
					66	— 3										
					66	— 3										
38	58	40	10	11	41	— 3	48	5.5	M6 × 1	17.3	14.9	500	1000	1500	2000	RS2040A**
					81	— 3										
					81	— 3										
46	70	48	12	13	50	— 3	58	6.6	M6 × 1	22.0	19.6	1000	2000	2500	RS2550A**	
					100	— 3										
					100	— 3										
58	92	60	12	15.5	126	— 3	74	9	M6 × 1	28.0	25.6	1000	2000	3000	4000	RS3264A**
						— 3										
						— 3										
73	114	75	15	19	158	— 3.5	93	11	M6 × 1	35.0	31.8	2000	3000	4000	5000	RS4080A**
						— 3.5										
						— 3.5										

Remarks 4. Items in stock are not applied surface treatment. NSK provides treatment such as phosphate coating on request.  
5. The entire length of the nut becomes longer by "2 x M " for those with a seal. The seal is "Brush-seal."





## Compact FA Series – E3230

### Main features:

Next-generation compact ball screws offer quiet, high speed operation performance.  
A standard stock series assures immediate delivery.



**Features:**

**6 dB less noise**

The noise level of ball screws has been reduced by 6 dB, about half of what is sensed by the ear. Ball screws subsequently produce a quieter and gentler sound.

**10%–30% more compact ball nut**

The outside diameter of the ball nut is as much as 30% smaller than those of NSK conventional products. This contributes to more compact design of all sorts of equipment and devices such as thinner XY tables.

**High-speed operation of up to 5 000 min<sup>-1</sup>**

The new ball screws offer 1.6 times faster rotational speed than conventional ballscrews. They handles speeds up to 5000 min<sup>-1</sup>. This capability dramatically expands the range of service conditions.

Note: Please refer to the dimension table for details of permissible rotational speed.

**Grease fitting provided as standard equipment**

The new ball screws are standardly equipped with a grease fitting (M5 × 0.8). Lubrication ports are provided in 2 places to facilitate maintenance. The ball screws can be easily connected to an integrated lubrication system.

**New type of contact seal**

A new model high-performance contact seal minimizes grease dispersion and helps to maintain a clean work environment.

**Low-profile design**

The low-profile support units especially compatible with the compact FA series are available for uniquely space-saving design.



Existing support unit — New low profile support

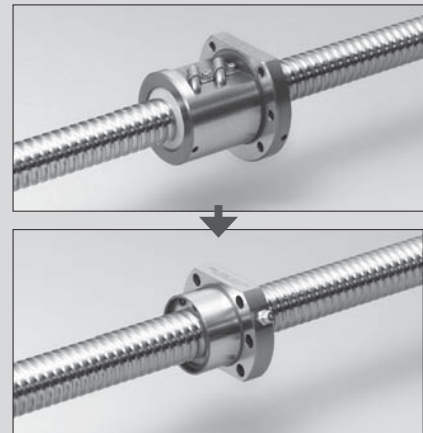
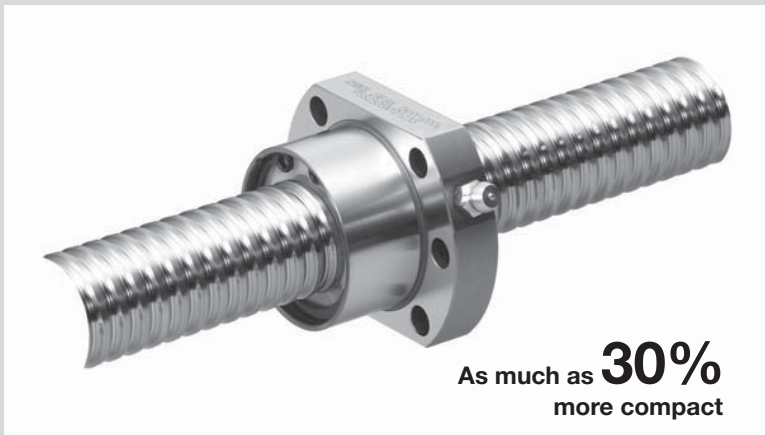
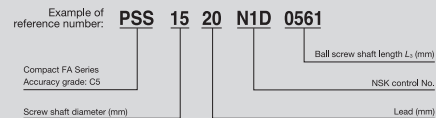

Shaft diameter	Lead	Stroke																Recommended support unit	
		50	100	150	200	300	400	500	600	700	800	1 000	1 200	1 600	2 000	Fixed side support unit	Simple side support unit		
10	5	●	●	●	●	●											WBK08-01B	WBK08S-01B	
	10	●	●	●	●	●	●										WBK08-01B	WBK08S-01B	
12	5	●	●	●	●	●	●										WBK08-01B	WBK08S-01B	
	10	●	●	●	●	●	●	●											
	20	●	●	●	●	●	●	●	●										
15	30	●	●	●	●	●	●	●	●								WBK12-01B WBK10-01B	WBK12S-01B	
	5	●	●	●	●	●	●	●	●										
	10	●	●	●	●	●	●	●	●	●									
	20	●	●	●	●	●	●	●	●	●	●								
20	30		●	●	●	●	●	●	●	●	●						WBK15-01B	WBK15S-01B	
	40		●	●	●	●	●	●	●	●	●	●							
	5		●	●	●	●	●	●	●	●	●	●	●						
	10		●	●	●	●	●	●	●	●	●	●	●	●					
	20		●	●	●	●	●	●	●	●	●	●	●	●	●				
25	30			●	●	●	●	●	●	●	●	●	●	●	●		WBK20-01	WBK20S-01	
	40			●	●	●	●	●	●	●	●	●	●	●	●				
	5			●	●	●	●	●	●	●	●	●	●	●	●				
	10			●	●	●	●	●	●	●	●	●	●	●	●				
	20			●	●	●	●	●	●	●	●	●	●	●	●				

Other support units are also available. See last page of catalog for details.

**Noise data**

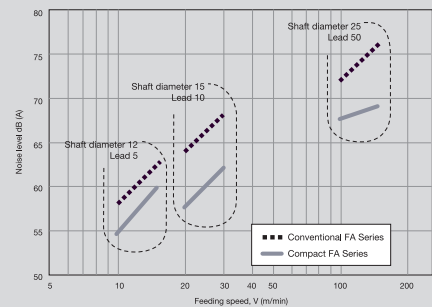

(Microphone was positioned at a distance of 400 mm for all noise measurements.)

Screw shaft  $\varnothing 10$   
Lead 5, 10

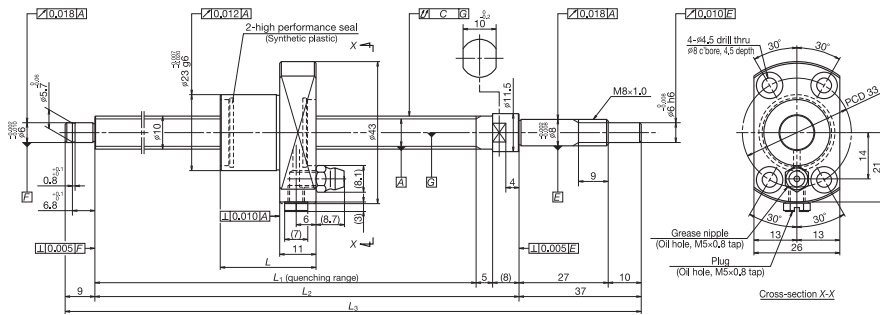

Ball screw specification	
Preload type	Enlarge ball preload (P-preload)
Ball diameter/screw shaft root diameter	2.000/8.2
Accuracy grade/axial play	C5/0
Factory pre-packed grease	NSK grease PS2

Recommended support unit	
WBK08-01B	(square, fixed side)
WBK08S-01B	(square, simple side)
WBK08-11B	(round, fixed side)

Reference number	Screw shaft diameter $d$	Lead $l$	Basic load ratings (N)		Stroke		Nut length $L$	Screw shaft dimensions			Lead accuracy			Shaft runout, C	Dynamic preload torque (N-cm) <sup>*1</sup>	Permissible rotational speed (min. <sup>-1</sup> ) <sup>*2</sup>							
			Dynamic $C_B$	Static $C_{0B}$	Nominal	Max. $L_1-L$		$L_1$	$L_2$	$L_3$	Target value $T$	Error $e_p$	Variation $v_v$										
PSS1005N1D0171	10	5	2 930	4 790	50	83	29	112	125	171	0	0.020	0.018	0.030	0.7	3.3							
PSS1005N1D0221								100	133	162							175	221	0.020	0.018	0.045	0.7	3.3
PSS1005N1D0321								200	230	262							275	321	0.023	0.018	0.060	0.6	4.3
PSS1005N1D0421								300	333	362							375	421	0.025	0.020	0.070	0.6	4.3
PSS1005N1D0521								400	433	462							475	521	0.027	0.020	0.085	0.4	4.9
PSS1010N1D0221								100	130	162							175	221	0.020	0.018	0.045	0.7	3.3
PSS1010N1D0321	10	1 970	3 010	200	230	32	262	275	321	0	0.023	0.018	0.060	0.6	4.3								
PSS1010N1D0421							300	330	362							375	421	0.025	0.020	0.070	0.6	4.3	
PSS1010N1D0421							300	330	362							375	421	0.027	0.020	0.085	0.4	4.9	

\*1. Indicates ball screw preload control value. About 2.0 N-cm of torque is added due to high performance seal. \*2. Contact NSK if permissible rotational speed is to be exceeded. \*3. Service temperature range is -20°C to 80°C

Screw shaft  $\varnothing 12$   
Lead 5, 10, 20, 30

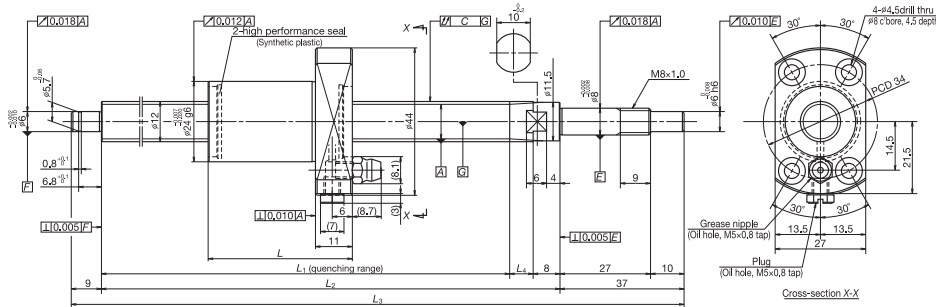

Ball screw specification	
Preload type	Enlarge ball preload (P-preload)
Ball diameter/screw shaft root diameter	2.000/10.2
Accuracy grade/axial play	C5/0
Factory pre-packed grease	NSK grease PS2

Recommended support unit	
WBK08-01B	(square, fixed side)
WBK08S-01B	(square, simple side)
WBK08-11B	(round, fixed side)

Unit: mm

Reference number	Screw shaft diameter $d$	Lead $l$	Basic load ratings (N)		Stroke		Nut length $L$	Screw shaft dimensions				Lead accuracy			Shaft runout, C	Dynamic preload torque (N-cm) <sup>*1</sup>	Permissible rotational speed (min. <sup>-1</sup> ) <sup>*2</sup>						
			Dynamic $C_B$	Static $C_{0B}$	Nominal	Max. $L_1-L$		$L_1$	$L_2$	$L_3$	$L_4$	Target value $T$	Error $e_p$	Variation $v_v$									
PSS1205N1D0171	12	5	3 200	5 860	50	80	30	110	125	171	0	0.020	0.018	0.030	0.7	3.3							
PSS1205N1D0221								100	130	160							175	221	0.020	0.018	0.045	0.7	3.3
PSS1205N1D0321								200	230	260							275	321	0.023	0.018	0.060	0.6	4.3
PSS1205N1D0421								300	330	360							375	421	0.025	0.020	0.070	0.6	4.3
PSS1205N1D0521								400	430	460							475	521	0.027	0.020	0.085	0.6	4.3
PSS1205N1D0621								500	530	560							575	621	0.030	0.023	0.095	0.4	4.9
PSS1210N1D0221	12	10	3 200	5 860	200	117	43	160	175	221	0	0.020	0.018	0.045	0.7	3.3							
PSS1210N1D0321								200	217	260							275	321	0.023	0.018	0.060	0.6	4.3
PSS1210N1D0421								300	317	360							375	421	0.025	0.020	0.070	0.6	4.3
PSS1210N1D0521	12	20	2 150	3 610	400	417	50	460	475	521	0	0.030	0.023	0.085	0.4	4.9							
PSS1210N1D0621								500	517	560							575	621	0.023	0.018	0.045	1.4	4.5
PSS1220N1D0271								100	158	208							225	271	0.023	0.018	0.060	0.9	4.9
PSS1220N1D0371								200	258	308							325	371	0.027	0.020	0.070	0.9	4.9
PSS1220N1D0471								300	358	408							425	471	0.030	0.023	0.085	0.6	5.9
PSS1220N1D0571								400	458	508							525	571	0.030	0.023	0.110	0.6	5.9
PSS1220N1D0671	12	30	2 150	3 610	500	558	70	608	625	671	0	0.023	0.018	0.060	0.9	4.9							
PSS1230N1D0271								100	133	203							225	271	0.027	0.020	0.070	0.9	4.9
PSS1230N1D0371								200	233	303							325	371	0.030	0.023	0.085	0.6	5.9
PSS1230N1D0471								300	333	403							425	471	0.030	0.023	0.110	0.6	5.9

\*1. Indicates ball screw preload control value. About 2.0 N-cm of torque is added due to high performance seal. \*2. Contact NSK if permissible rotational speed is to be exceeded. \*3. Service temperature range is -20°C to 80°C

Screw shaft  $\phi 15$   
Lead 5, 10

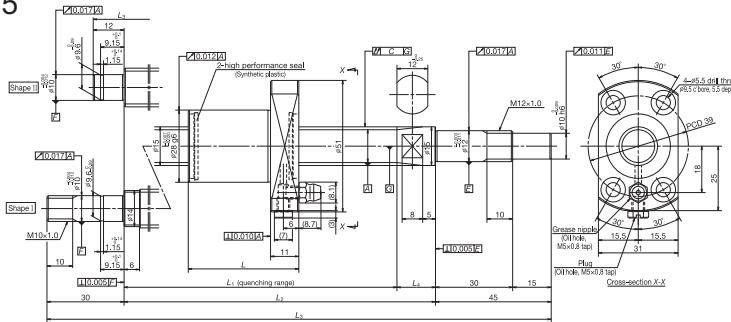

**Ball screw specification**  
 Preload type: Oversize ball preload (P-preload)  
 Ball diameter/screw shaft root diameter: 2.7781/12.6  
 Accuracy grade/axial play: C5/0  
 Factory pre-packed grease: NSK grease LR3

**Recommended support unit**  
 WBK12-01B (square, fixed side)  
 WBK12S-01B (square, simple side)  
 WBK12-11 (round, fixed side)  
 \*WBK10-01B (square, fixed side)  
 WBK10-11 (round, fixed side)

Reference number	Screw shaft diameter $d$	Lead $l$	Basic load ratings (N)		Stroke		Nut length $L$	Screw shaft dimensions				Lead accuracy			Shaft runout $C$	Dynamic preload torque (N-cm) <sup>*1</sup>	Permissible rotational speed (min <sup>-1</sup> ) <sup>*2</sup>		Left shaft end (opposite driven side)		
			Dynamic $C_a$	Static $C_{0a}$	Nominal	Max. $L_1-L_2$		$L_1$	$L_2$	$L_3$	$L_4$	Target value $T$	Error $\sigma_p$	Variation $\sigma_v$			Fixed	Simple			
																				Fixed	Simple
PSS1505N1D0211	15	5	5 460	10 200	50	109	30	139	154	211	15	0	0.020	0.018	0.035	0.2	-	6.9	5 000	-	Shape II
PSS1505N1D0261					100	159		189	204	261			0.023	0.018	0.035	0.2	-	6.9			
PSS1505N1D0311					200	259		289	304	361			0.025	0.020	0.050	0.4	-	9.8			
PSS1505N1D0461					300	359		389	404	461			0.027	0.020	0.060	0.4	-	9.8			
PSS1505N1D0561					400	459		489	504	561			0.030	0.023	0.075	0.4	-	9.8			
PSS1505N1D0661					500	559		589	604	661			0.035	0.025	0.075	0.4	-	11.8			
PSS1505N1D0761		600	659	689	704	761	43	189	204	261	15	0	0.020	0.018	0.035	0.6	-	7.4	5 000	-	Shape II
PSS1510N1D0261		100	146	289	304	361		0.023	0.018	0.045			0.6	-	7.4						
PSS1510N1D0361		200	246	389	404	461		0.025	0.020	0.050			0.4	-	9.8						
PSS1510N1D0461		300	346	489	504	561		0.027	0.020	0.060			0.4	-	9.8						
PSS1510N1D0561		400	446	589	604	661		0.030	0.023	0.075			0.4	-	9.8						
PSS1510N1D0661		500	546	689	704	761		0.035	0.025	0.075			0.4	-	11.8						
PSS1510N1D0761	600	646	789	804	879	45	789	804	879	15	0	0.035	0.025	0.095	0.4	-	11.8	2 700	3 400	Shape I	
PSS1510N1D0879	700	746	889	904	979		0.040	0.027	0.095			0.4	-	11.8	2 200	3 400					
PSS1510N1D0979	800	846	889	904	979		0.046	0.030	0.120			0.4	-	11.8	1 400	2 300					
PSS1510N1D1179	1 000	1 046	1 089	1 104	1 179																

\*1. Indicates ball screw preload control value. About 2.0 N-cm of torque is added due to high performance seal. \*2. Contact NSK if permissible rotational speed is to be exceeded. \*3. Service temperature range is -20°C to 80°C. \*4. WBK 10-01B and WBK 10-11 are for shape I.

Screw shaft  $\phi 15$   
Lead 20, 30

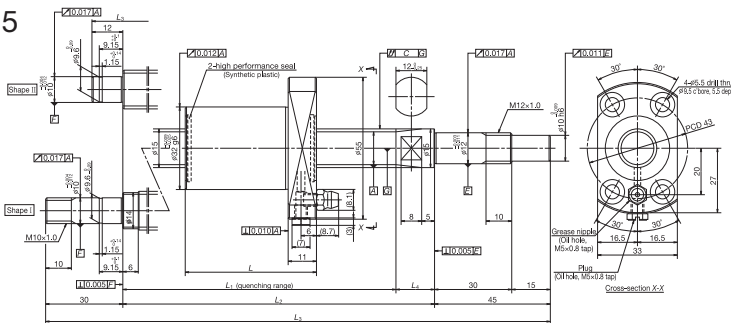

**Ball screw specification**  
 Preload type: Oversize ball preload (P-preload)  
 Ball diameter/screw shaft root diameter: 3.175/12.2  
 Accuracy grade/axial play: C5/0  
 Factory pre-packed grease: NSK grease LR3

**Recommended support unit**  
 WBK12-01B (square, fixed side)  
 WBK12S-01B (square, simple side)  
 WBK12-11 (round, fixed side)  
 \*WBK10-01B (square, fixed side)  
 WBK10-11 (round, fixed side)

Reference number	Screw shaft diameter $d$	Lead $l$	Basic load ratings (N)		Stroke		Nut length $L$	Screw shaft dimensions				Lead accuracy			Shaft runout $C$	Dynamic preload torque (N-cm) <sup>*1</sup>	Permissible rotational speed (min <sup>-1</sup> ) <sup>*2</sup>		Left shaft end (opposite driven side)						
			Dynamic $C_a$	Static $C_{0a}$	Nominal	Max. $L_1-L_2$		$L_1$	$L_2$	$L_3$	$L_4$	Target value $T$	Error $\sigma_p$	Variation $\sigma_v$			Fixed	Simple							
																				Fixed	Simple				
PSS1520N1D0261	15	20	5 070	8 730	100	135	51	186	204	261	18	0	0.020	0.018	0.035	0.8	-	8.8	5 000	-	Shape II				
PSS1520N1D0361					200	235		286	304	361			0.023	0.018	0.045	0.8	-	8.8							
PSS1520N1D0461					300	335		386	404	461			0.025	0.020	0.050	0.8	-	10.8							
PSS1520N1D0561					400	435		486	504	561			0.027	0.020	0.060	0.8	-	10.8							
PSS1520N1D0661					500	535		586	604	661			0.030	0.023	0.075	0.8	-	10.8							
PSS1520N1D0761					600	635		686	704	761			0.035	0.025	0.075	0.8	-	13.8							
PSS1520N1D0879		700	735	786	804	879	71	786	804	879	24	0	0.035	0.025	0.095	0.8	-	13.8	2 900	4 200	Shape I				
PSS1520N1D0979		800	835	886	904	979		0.040	0.027	0.095			0.8	-	13.8	2 200	3 300								
PSS1520N1D1179		1 000	1 035	1 086	1 104	1 179		0.046	0.030	0.120			0.8	-	13.8	1 500	2 200								
PSS1530N1D0311		100	159	230	254	311		45	230	254			311	15	0	0.023	0.018	0.035	1.2	-		9.3	5 000	-	Shape II
PSS1530N1D0411		200	259	330	354	411			0.025	0.020			0.050			0.8	-	10.8							
PSS1530N1D0511		300	359	430	454	511			0.027	0.020			0.060			0.8	-	10.8							
PSS1530N1D0611	400	459	530	554	611	0.030	0.023		0.060	0.8	-	10.8													
PSS1530N1D0711	500	559	630	654	711	0.035	0.025		0.075	0.8	-	13.8													
PSS1530N1D0811	600	659	730	754	811	0.040	0.027		0.095	0.8	-	13.8													
PSS1530N1D0929	700	759	830	854	929	45	830	854	929	15	0	0.040	0.027	0.120	0.8	-	13.8	2 000	3 000	Shape I					
PSS1530N1D1029	800	859	930	954	1 029		0.046	0.030	0.120			0.8	-	13.8	1 400	2 000									

\*1. Indicates ball screw preload control value. About 2.0 N-cm of torque is added due to high performance seal. \*2. Contact NSK if permissible rotational speed is to be exceeded. \*3. Service temperature range is -20°C to 80°C. \*4. WBK 10-01B and WBK 10-11 are for shape I.

Screw shaft  $\phi 20$   
Lead 5, 10, 20, 30, 40, 60

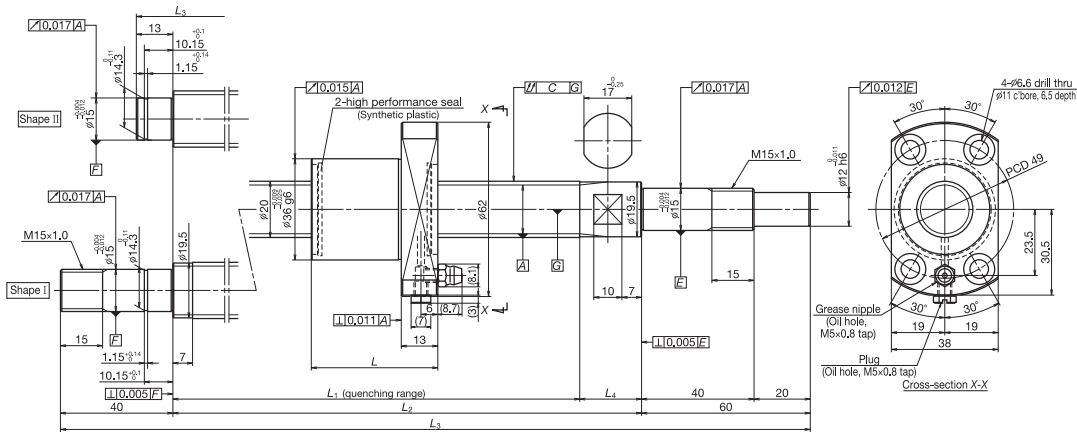

Ball screw specification

Preload type  
Ball diameter/screw shaft root diameter  
Accuracy grade/axial play  
Factory pre-packed grease

Enlarge ball preload (P-preload)  
3.175/17.2  
C5/0  
NSK grease LR3

Recommended support unit

WBK15-01B (square, fixed side)  
WBK155-01B (square, simple side)  
WBK15-11 (round, fixed side)

Reference number	Screw shaft diameter $d$	Lead $l$	Basic load ratings (N)		Stroke		Nut length $L$	Screw shaft dimensions				Lead accuracy			Shaft runout $C$	Dynamic preload torque (N cm) <sup>†1</sup>	Permissible rotational speed (min <sup>-1</sup> ) <sup>†2</sup>		Left shaft end (opposite driver side)										
			Dynamic $C_d$	Static $C_{0a}$	Nominal	Max. $L_1-L$		$L_1$	$L_2$	$L_3$	$L_4$	Target value $T$	Error $e_p$	Variation $v_p$			Fixed-Simple	Fixed-Fixed											
																				8 790	18 500	5 000	4 700						
PSS2005N1D0323	20	5	8 790	18 500	31	150	197	228	250	328	22	0.023	0.018	0.045	0.6	7.4	5 000	-	Shape II										
PSS2005N1D0373																				200	247	278	300	373	0.025	0.020	0.050	0.6	7.4
PSS2005N1D0473																				300	347	378	400	473	0.027	0.020	0.060	0.4	9.8
PSS2005N1D0673																				400	447	478	500	573	0.030	0.023	0.075	0.4	9.8
PSS2005N1D0773																				500	547	578	600	673	0.035	0.025	0.075	0.4	9.8
PSS2005N1D0873																				600	647	678	700	773	0.035	0.025	0.095	0.4	9.8
PSS2005N1D1000																				700	747	778	800	873	0.040	0.027	0.095	0.4	11.8
PSS2010N1D0387																				800	847	878	900	1000	0.023	0.018	0.045	1.2	9.3
PSS2010N1D0487																				200	247	292	314	387	0.025	0.020	0.050	1.2	9.3
PSS2010N1D0587																				300	347	392	414	487	0.027	0.020	0.060	0.8	10.8
PSS2010N1D0687																				400	447	492	514	587	0.030	0.023	0.075	0.8	10.8
PSS2010N1D0787																				500	547	592	614	687	0.035	0.025	0.075	0.8	10.8
PSS2010N1D0887	600	647	692	714	787	0.035	0.025	0.095	0.8	10.8																			
PSS2010N1D1014	700	747	792	814	887	0.040	0.027	0.095	0.8	10.8																			
PSS2010N1D1214	800	847	892	914	1014	0.046	0.030	0.120	0.8	13.8																			
PSS2010N1D1414	1 000	1 047	1 092	1 114	1 214	0.054	0.035	0.160	0.8	13.8																			
PSS2020N1D0508	20	10	8 790	18 500	45	300	359	413	435	508	22	0.027	0.020	0.060	1.4	11.8	5 000	-	Shape II										
PSS2020N1D0608																				400	459	513	535	608	0.030	0.023	0.090	1.4	11.8
PSS2020N1D0708																				500	559	613	635	708	0.030	0.023	0.075	1.4	11.8
PSS2020N1D0808																				600	659	713	735	808	0.035	0.025	0.095	1.4	11.8
PSS2020N1D0908																				700	759	813	835	908	0.040	0.027	0.095	0.8	13.8
PSS2020N1D1035																				800	859	913	935	1 035	0.040	0.027	0.120	0.8	13.8
PSS2020N1D1235																				1 000	1 059	1 113	1 135	1 235	0.046	0.030	0.120	0.8	13.8
PSS2020N1D1435																				1 200	1 259	1 313	1 335	1 435	0.054	0.035	0.160	0.8	13.8
PSS2020N1D1835																				1 600	1 659	1 713	1 735	1 835	0.065	0.040	0.200	0.8	13.8
PSS2030N1D0408																				200	234	308	335	408	0.023	0.018	0.050	1.6	9.8
PSS2030N1D0508																				300	334	408	435	508	0.027	0.020	0.060	1.4	11.8
PSS2030N1D0608																				400	434	508	535	608	0.030	0.023	0.090	1.4	11.8
PSS2030N1D0708	500	534	608	635	708	0.030	0.023	0.075	1.4	11.8																			
PSS2030N1D0808	600	634	708	735	808	0.035	0.025	0.095	1.4	11.8																			
PSS2030N1D0908	700	734	808	835	908	0.040	0.027	0.095	0.8	13.8																			
PSS2030N1D1035	800	834	908	935	1 035	0.040	0.027	0.120	0.8	13.8																			
PSS2030N1D1235	1 000	1 034	1 108	1 135	1 235	0.046	0.030	0.120	0.8	13.8																			
PSS2030N1D1435	1 200	1 234	1 308	1 335	1 435	0.054	0.035	0.160	0.8	13.8																			
PSS2040N1D0658	20	20	5 900	11 700	74	400	461	533	585	658	27	0.030	0.023	0.075	2.2	12.8	5 000	-	Shape II										
PSS2040N1D0758																				500	561	653	685	758	0.035	0.025	0.075	2.2	12.8
PSS2040N1D0858																				600	661	753	785	858	0.035	0.025	0.095	2.2	12.8
PSS2040N1D0958																				700	761	853	885	958	0.040	0.027	0.095	1.8	14.8
PSS2040N1D1085																				800	861	953	985	1 085	0.040	0.027	0.120	1.8	14.8
PSS2040N1D1285																				1 000	1 061	1 153	1 185	1 285	0.046	0.030	0.160	1.8	14.8
PSS2040N1D1485																				1 200	1 261	1 353	1 385	1 485	0.054	0.035	0.160	1.8	14.8
PSS2040N1D1885																				1 600	1 661	1 753	1 785	1 885	0.065	0.040	0.200	1.8	14.8
PSS2040N1D2285																				2 000	2 061	2 153	2 185	2 285	0.077	0.046	0.240	1.8	14.8
PSS2060N1D0708																				400	464	593	635	708	0.030	0.023	0.075	2.7	13.8
PSS2060N1D0808																				500	564	693	735	808	0.035	0.025	0.095	2.7	13.8
PSS2060N1D0908																				600	664	793	835	908	0.035	0.025	0.095	2.7	13.8
PSS2060N1D1008	700	764	893	935	1 008	0.040	0.027	0.120	1.8	14.8																			
PSS2060N1D1135	800	864	993	1 035	1 135	0.040	0.027	0.120	1.8	14.8																			
PSS2060N1D1335	1 000	1 064	1 193	1 235	1 335	0.046	0.030	0.160	1.8	14.8																			
PSS2060N1D1535	1 200	1 264	1 393	1 435	1 535	0.054	0.035	0.160	1.8	14.8																			
PSS2060N1D1935	1 600	1 664	1 793	1 835	1 935	0.065	0.040	0.200	1.8	14.8																			
PSS2060N1D2335	2 000	2 064	2 193	2 235	2 335	0.077	0.046	0.240	1.8	14.8																			

<sup>†1</sup>. Indicates ball screw preload control value. About 3.0 N cm of torque is added due to high performance seal. <sup>†2</sup>. Contact NSK if permissible rotational speed is to be exceeded. <sup>†3</sup>. Service temperature range is -20°C to 80°C.



Screw shaft  $\phi 25$   
Lead 5, 10, 20, 25, 30, 50

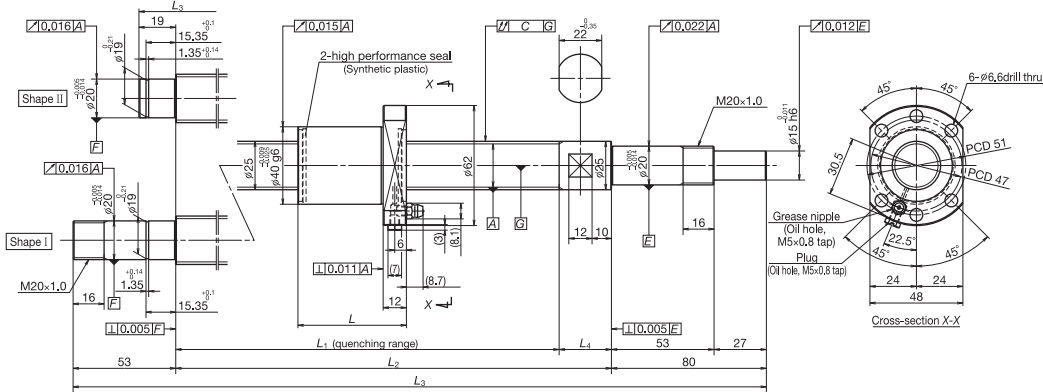

Ball screw specification

- Preload type
- Ball diameter/screw shaft root diameter
- Accuracy grade/axial play
- Factory pre-packed grease

- Oversize ball preload (P-preload) 3.175/22.2
- C5/0
- NSK grease LR3

Recommended support unit

- WBK20-01 (square, fixed side)
- WBK20S-01 (square, simple side)
- WBK20-11 (round, fixed side)

Reference number	Screw shaft diameter $\phi$	Lead $l$	Basic load ratings (N)		Stroke		Nut length $L$	Screw shaft dimensions				Lead accuracy			Shaft runout $C$	Dynamic preload torque (N·cm) <sup>1)</sup>	Permissible rotational speed (min) <sup>2)</sup>		Left shaft end (opposite driven side)
			Dynamic $C_d$	Static $C_{0a}$	Nominal	Max. $L_1-L$		$L_1$	$L_2$	$L_3$	$L_4$	Target value $T$	Error $e_p$	Variation $v_p$			Fixed-Simple	Fixed-Fixed	
PSS2505N1D0349	5	9 760	23 600	150	191	223	250	349	27	0	0.023	0.018	0.035	1.2	9.3	5 000	-	Shape II	
PSS2505N1D0399				200	241	273	300	399			0.023	0.018	0.035	1.2	9.3				
PSS2505N1D0499				300	341	373	400	499			0.025	0.020	0.040	1.2	9.3				
PSS2505N1D0599				400	441	473	500	599			0.027	0.020	0.045	1.2	9.3				
PSS2505N1D0699				500	541	573	600	699			0.030	0.023	0.055	0.8	10.8				
PSS2505N1D0899				700	741	773	800	899			0.035	0.025	0.065	0.8	10.8				
PSS2510N1D0999		800	841	873	900	999	0.040	0.027	0.065		0.8	10.8	4 100	5 000	-	Shape I			
PSS2510N1D1233		1 000	1 041	1 073	1 100	1 233	0.046	0.030	0.080		0.8	13.8	2 700						
PSS2510N1D0549		300	367	423	450	549	0.027	0.020	0.045		3.1	11.8	5 000				-	Shape II	
PSS2510N1D0649		400	467	523	550	649	0.030	0.023	0.055		2.2	12.8							
PSS2510N1D0749		500	567	623	650	749	0.030	0.023	0.055		2.2	12.8							
PSS2510N1D0849		600	667	723	750	849	0.035	0.025	0.065		2.2	12.8							
PSS2510N1D0949	700	767	823	850	949	0.040	0.027	0.065	2.2	12.8									
PSS2510N1D1049	800	867	923	950	1 049	0.046	0.027	0.080	2.2	12.8	3 600								
PSS2520N1D0999	1 000	1 041	1 123	1 150	1 283	0.046	0.030	0.100	1.8	14.8	2 500	3 700	-	Shape I					
PSS2510N1D1883	1 600	1 667	1 723	1 750	1 883	0.065	0.040	0.130	1.8	14.8	1 000	1 600							
PSS2520N1D0729	500	550	604	630	729	0.030	0.023	0.055	2.2	12.8	5 000	-			Shape II				
PSS2520N1D0829	600	650	704	730	829	0.035	0.025	0.065	2.2	12.8									
PSS2520N1D0929	700	750	804	830	929	0.040	0.027	0.065	2.2	12.8									
PSS2520N1D1029	800	850	904	930	1 029	0.040	0.027	0.080	2.2	12.8									
PSS2520N1D1263	1 000	1 050	1 104	1 130	1 263	0.046	0.030	0.100	1.8	14.8			2 600	3 900					
PSS2530N1D1463	1 200	1 250	1 304	1 330	1 463	0.054	0.035	0.100	1.8	14.8			1 800	2 700					
PSS2520N1D1883	1 600	1 650	1 704	1 730	1 883	0.065	0.040	0.130	1.8	14.8	1 100	1 600	-	Shape I					
PSS2520N1D2263	2 000	2 050	2 104	2 130	2 263	0.077	0.046	0.170	1.8	14.8	700	1 000							
PSS2525N1D0779	500	587	650	680	779	0.035	0.025	0.055	2.7	13.8	5 000	-			Shape II				
PSS2525N1D0879	600	687	750	780	879	0.035	0.025	0.065	2.7	13.8									
PSS2525N1D0979	700	787	850	880	979	0.040	0.027	0.065	2.7	13.8									
PSS2525N1D1079	800	887	950	980	1 079	0.040	0.027	0.080	2.7	13.8									
PSS2525N1D1313	1 000	1 087	1 150	1 180	1 313	0.046	0.030	0.100	1.8	14.8			2 300	3 300					
PSS2525N1D1513	1 200	1 287	1 350	1 380	1 513	0.054	0.035	0.100	1.8	14.8			1 700	2 600					
PSS2525N1D1913	1 600	1 687	1 750	1 780	1 913	0.065	0.040	0.130	1.8	14.8	1 000	1 500	-	Shape I					
PSS2525N1D2313	2 000	2 087	2 150	2 180	2 313	0.077	0.046	0.170	1.8	14.8	700	1 000							
PSS2530N1D0779	500	576	650	680	779	0.035	0.025	0.055	2.7	13.8	5 000	-			Shape II				
PSS2530N1D0879	600	676	750	780	879	0.035	0.025	0.065	2.7	13.8									
PSS2530N1D0979	700	776	850	880	979	0.040	0.027	0.065	2.7	13.8									
PSS2530N1D1079	800	876	950	980	1 079	0.040	0.027	0.080	2.7	13.8									
PSS2530N1D1313	1 000	1 076	1 150	1 180	1 313	0.046	0.030	0.100	1.8	14.8			2 300	3 300					
PSS2530N1D1513	1 200	1 276	1 350	1 380	1 513	0.054	0.035	0.100	1.8	14.8			1 700	2 600					
PSS2530N1D1913	1 600	1 676	1 750	1 780	1 913	0.065	0.040	0.130	1.8	14.8	1 000	1 500	-	Shape I					
PSS2530N1D2313	2 000	2 076	2 150	2 180	2 313	0.077	0.046	0.170	1.8	14.8	700	1 000							
PSS2550N1D0829	500	576	690	730	829	0.035	0.025	0.065	5.4	17.6	5 000	-			Shape II				
PSS2550N1D0929	600	676	790	830	929	0.035	0.025	0.065	5.4	17.6									
PSS2550N1D1029	700	776	890	930	1 029	0.040	0.027	0.080	5.4	17.6									
PSS2550N1D1129	800	876	990	1 030	1 129	0.040	0.027	0.080	5.4	17.6									
PSS2550N1D1363	1 000	1 076	1 190	1 230	1 363	0.046	0.030	0.100	4.1	19.6			2 200	3 400					
PSS2550N1D1563	1 200	1 276	1 390	1 430	1 563	0.054	0.035	0.100	4.1	19.6			1 600	2 500					
PSS2550N1D1963	1 600	1 676	1 790	1 830	1 963	0.065	0.040	0.130	4.1	19.6	900	1 500	-	Shape I					
PSS2550N1D2363	2 000	2 076	2 190	2 230	2 363	0.077	0.046	0.170	4.1	19.6	600	1 000							

<sup>1)</sup> Indicates ball screw preload control value. About 3.0 N·cm of torque is added due to high performance seal. <sup>2)</sup> Contact NSK if permissible rotational speed is to be exceeded. <sup>3)</sup> Service temperature range is -20°C to 80°C.

## ◇ Design

- (1) If a ball screw of which left shaft end (opposite driven side) is the shape I, and is supported with the “fixed-fixed” supporting method, you should be aware that the operating life of support bearings may drop due to thermal expansion of the screw shaft, depending on usage conditions. In this case, you should consider a structure that can absorb thermal expansion of the screw shaft if necessary. Please consult with NSK for a detailed examination.
- (2) If using an NSK linear guide, the maximum speed of a linear guide of standard specifications under ordinary conditions is limited to 100 m/min. A linear guide with high-speed specifications is available if higher operating speed is required. Contact NSK for further information.
- (3) For general precautions concerning ball screws, please see NSK Catalog No. E3161 “Precision Machine Components.”

## ◇ Usage and handling

Ball screws are precision products and should be treated as follows:

### [Lubrication]

- (1) Compact FA Series ball screws are packed and coated with lubrication grease at the factory, and require no further lubrication under ordinary circumstances. If the surface of the grease becomes contaminated with dirt and metal powder under operation, clean it with white kerosene and replenish with new grease of the same kind through the oil hole (grease nipple) on the ball nut. Avoid mixing different types of grease.
- (2) Lubricant should be checked after the first 2 to 3 months of operation. If excessively dirty, we recommend you wipe away the old grease and replenish with a generous quantity of grease. After that, grease should be checked and replenished once a year under ordinary circumstances, but the period may vary depending upon the service environment.

### [Handling]

- (1) Never disassemble the ball screw, otherwise dirt may contaminate the inside of the unit and affect precision or result in equipment failure.
- (2) Compact FA Series ball screws incorporate a new ball re-circulation system. Consequently, only NSK authorized plants should conduct disassembly and reassembly. If the nut accidentally comes off the screw shaft or is dropped, NSK will check precision, problems or perform repairs at your expense.
- (3) When the ball screw is erected upright, the screw shaft or nut could fall by force of its own weight and result in injury. If dropped, the ball grooves could be dented or re-circulation parts damaged, resulting in loss of function. This would require the ball screw to be inspected by NSK. If so, be sure to send the ball screw to NSK and we will check it for a fee.

### [Usage]

- (1) Ball screws should be used in a clean environment. The ball screws should be provided with a dust cover to prevent the entry of debris such as dust and metal powder. If foreign matter is allowed to contaminate the ball screw, this could not only cause the ball screw to lose some of its function, but also result in clogging and damaging the re-circulation system parts, or cause the table to fall or a similar serious accident.
- (2) Compact FA Series ball screws are designed to be used in a service temperature environment of 80°C or lower. Do not allow the service temperature limit to be exceeded. In some cases, using ball screws in temperatures above 80°C might lead to damage of re-circulation system parts or seal parts. Contact NSK if 80°C must be exceeded.

## ◇ Compact FA Series options

Consult with NSK for information about optional specification not given in the catalog such as shaft end machining, reverse direction ball nut, alternative grease, surface treatment, and alternative preload.



NSK has developed a series of low-profile support unit to be used with the ball screws of compact FA series. A combination of the ball screw and the support unit offers a compact design for downsizing of many kinds of machinery.

## Features

The low-profile support units offer the low center height construction suited for the compact FA series ball screws.

## Product configuration

All parts required for ball screw mounting are provided as a set (see the table below). The bearing housing of support unit for fixed side contains a built-in angular contact ball bearings and oil seal and should not be disassembled.

Fixed side support unit

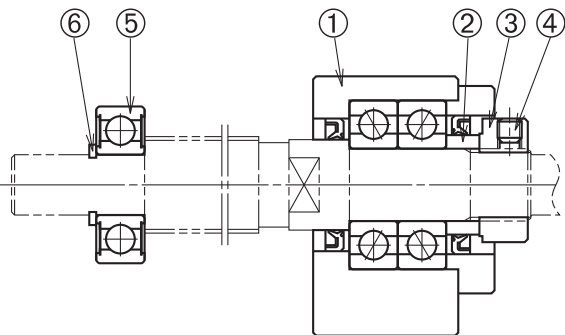

Part No.	Part	Remarks (surface treatment, grease)
①	Bearing housing	Triiron tetroxide film
	Angular contact ball bearing	PS2
	Oil seal	
	Cover	Triiron tetroxide film
②	Spacer	
③	Lock nut	Triiron tetroxide film
④	Setscrew	Triiron tetroxide film
⑤	Deep groove ball bearing	Comes with support side, PS2
⑥	Snap ring	Triiron tetroxide film
Other machine screws are either made of stainless steel or coated with triiron tetroxide film.		

Simple side support unit

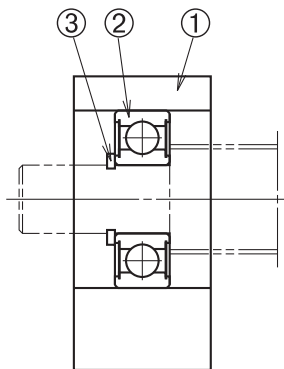

Part No.	Part	Remarks (surface treatment, grease)
①	Bearing housing	Triiron tetroxide film
②	Deep groove ball bearing	PS2
③	Snap ring	Triiron tetroxide film

## Reference number

Example: **WBK 08 S - 01 B**

Support unit product code

Nominal size code (internal bore of bearing)\*

No code or A: conventional standard support unit  
B: Low-profile support unit

01: Square type, 11: Round type  
Mounting code

No code: Fixed side support unit  
S: Simple side support unit

\*For simple side support units, please note that size codes of 12 or less do not represent internal bores of bearing.

Fixed side support unit (square type)

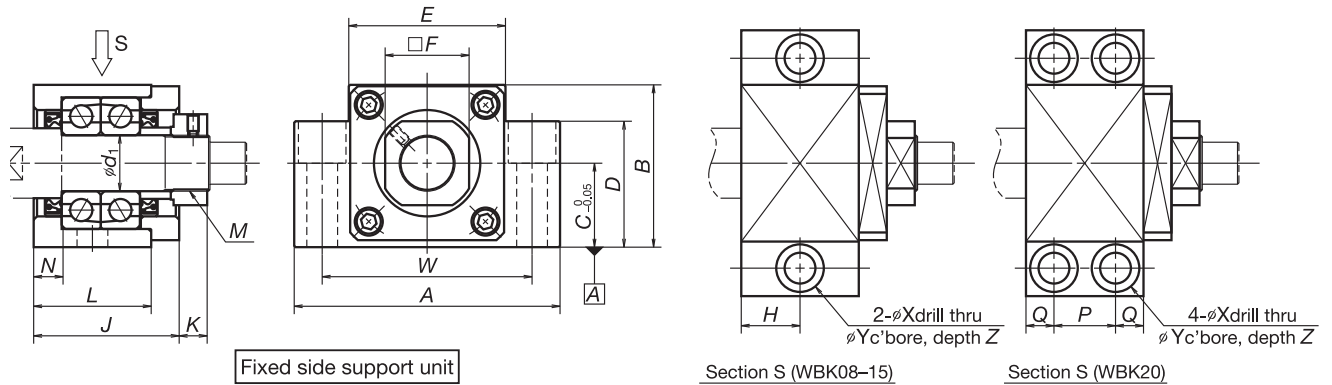

Fixed side support unit

Section S (WBK08-15)

Section S (WBK20)

Unit: mm

Screw shaft diameter	Fixed side support unit (square type)																			
	Reference number	$d_1$	A	B	C	D	E	F	H	J	K	L	N	P	Q	W	X	Y	Z	M
$\phi 10$	WBK08-01A	8	52	32	17	26	25	14	11.5	23	7	—	4	—	—	38	6.6	11	12	M8X1
$\phi 12$	WBK08-01B	8	62	31	15.5	—	—	14	11	25.5	4.5	21.5	3.5	—	—	46	9	14	18	M8X1
$\phi 15$	WBK10-01B*	10	70	38	20	—	—	17	12	30	5.5	24	6	—	—	52	9	14	19	M10X1
	WBK12-01A	12	70	43	25	35	36	19	12	30	5.5	24	6	—	—	52	9	14	11	M12X1
	WBK12-01B	12	70	38	20	—	—	19	12	30	5.5	24	6	—	—	52	9	14	19	M12X1
$\phi 20$	WBK15-01A	15	80	50	30	40	41	22	12.5	31	12	25	5	—	—	60	11	17	15	M15X1
	WBK15-01B	15	80	42	22	—	—	22	12.5	31	12	25	5	—	—	60	11	17	23	M15X1
$\phi 25$	WBK20-01	20	95	58	30	45	56	30	—	52	10	42	10	22	10	75	11	17	15	M20X1

\*Use support unit for fixing side for opposite drive side of shaft diameter  $\phi 15$ .

- Remarks
1. Mount to the base using side A as the reference.
  2. Tighten the setscrew after tightening the lock nut and adjusting.
  3. Insert the set piece and then tighten the setscrew.

Simple side support unit

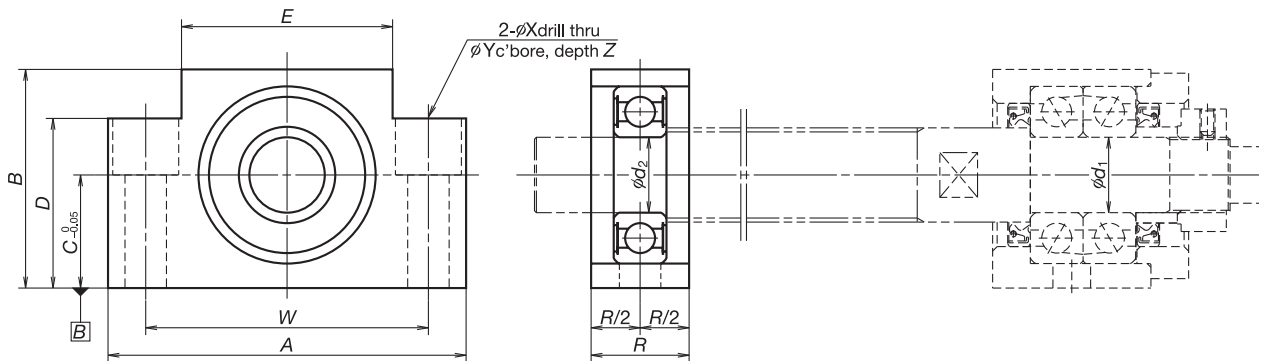

Unit: mm

Screw shaft diameter	Simple side support unit											
	Reference number	$d_2$	A	B	C	D	E	R	W	X	Y	Z
$\phi 10$	WBK08S-01	6	52	32	17	26	25	15	38	6.6	11	12
$\phi 12$	WBK08S-01B	6	62	31	15.5	—	—	16	46	9	14	18
$\phi 15$	WBK12S-01	10	70	43	25	35	36	20	52	9	14	11
	WBK12S-01B	10	70	38	20	—	—	20	52	9	14	19
$\phi 20$	WBK15S-01	15	80	50	30	40	41	20	60	9	14	11
	WBK15S-01B	15	80	42	22	—	—	20	60	9	14	23
$\phi 25$	WBK20S-01	20	95	58	30	45	56	26	75	11	17	15

- Remarks
1. Mount to the base using side B as the reference.

Fixed side support unit (round type)

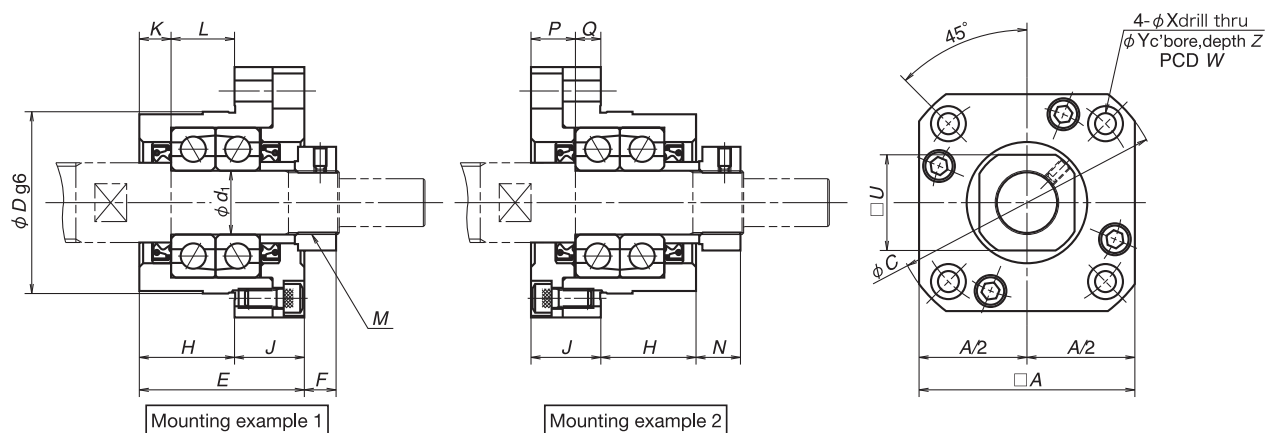

Unit: mm

Screw shaft diameter	Fixed side support unit (round type)																			
	Reference number	$d_1$	A	C	D	E	F	H	J	K	L	N	P	Q	U	W	X	Y	Z	M
$\phi 10$	WBK08-11	8	35	43	28	23	7	14	9	4	10	8	5	4	14	35	3.4	6.5	4	M8X1
$\phi 12$	WBK08-11B	8	42	52	34	25.5	4.5	15.5	10	3.5	12	7	6	4	14	42	4.5	8	4	M8X1
$\phi 15$	WBK10-11*	10	42	52	34	27	7.5	17	10	5	12	8.5	6	4	17	42	4.5	8	4	M10X1
	WBK12-11	12	44	54	36	27	7.5	17	10	5	12	8.5	6	4	19	44	4.5	8	4	M12X1
$\phi 20$	WBK15-11	15	52	63	40	32	12	17	15	6	11	14	8	7	22	50	5.5	9.5	6	M15X1
$\phi 25$	WBK20-11	20	68	85	57	52	10	30	22	10	20	14	14	8	30	70	6.6	11	10	M15X1

\*Use support unit for fixing side for opposite drive side of shaft diameter 15.

- Remarks
1. Tighten the setscrew after tightening the lock nut and adjusting.
  2. Insert the set piece and then tighten the setscrew.

Specifications of support unit

Screw shaft diameter	Fixed side support unit					Simple side support unit			
	Support unit reference number	Axial load		Maximum starting torque	Tightening torque [N-cm]		Support unit reference number	Bearing number	Radial load Basic load ratings C [N]
		Basic load ratings $C_a$ [N]	Load limit [N]		Lock nut	Setscrew			
$\phi 10$	WBK08-01A (square type)	4 400	1 450	0.88	490	69 (M3)	WBK08S-01	606ZZ	2 260
	WBK08-11 (round type)						—		
$\phi 12$	WBK08-01B (square low-profile type)	6 600	2 730	1.9	930	147 (M4)	WBK08S-01B	6000ZZ	4 550
	WBK08-11B (round type)						—		
$\phi 15$	WBK10-01B (square low-profile type)*	7 100	3 040	2.1	1 370	147 (M4)	WBK12S-01	6002ZZ	5 600
	WBK10-11 (round type)						—		
	WBK12-01A (square type)						WBK12S-01B		
	WBK12-01B (square low-profile type)						—		
$\phi 20$	WBK12-11 (round type)	7 600	3 380	2.3	2 350	147 (M4)	WBK15S-01	6204ZZ	12 800
	WBK15-01A (square type)						WBK15S-01B		
	WBK15-01B (square low-profile type)						—		
$\phi 25$	WBK15-11 (round type)	17 900	8 240	5.4	4 700	147 (M4)	WBK20S-01	6204ZZ	12 800
	WBK20-01 (square type)						—		
	WBK20-11 (round type)								

\*Use support unit for fixing side for opposite drive side of shaft diameter 15.

## WBK Support Units

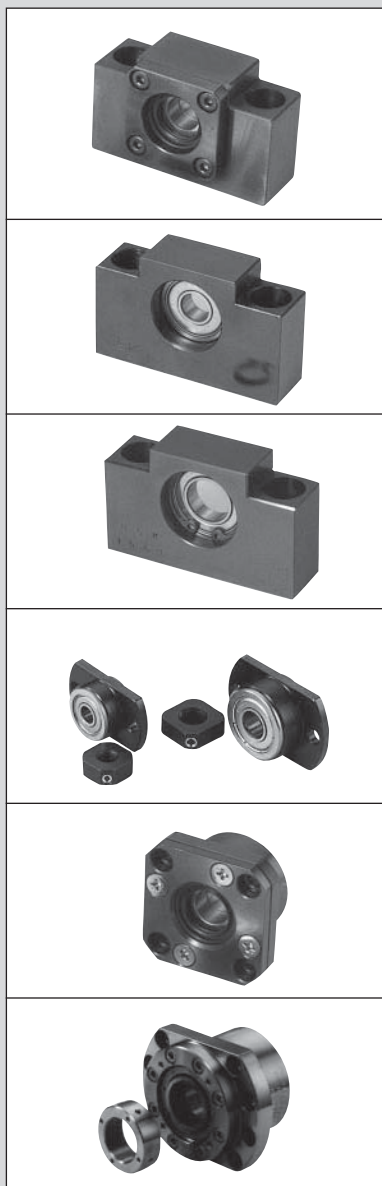

### Support units

#### ① Classification

Ball screw support units are classified into categories by their shape. Select the type that is appropriate for you to use.

#### ② Features







- Short delivery time: Standardized items in stock
- Use most suitable bearings
  - On the fixed support side, the angular contact ball bearing is used. It has great rigidity and low friction torque which match the rigidity of the ball screw.
  - The thrust angular contact ball bearing with high precision and great rigidity is another choice for the fixed support side.
- High dust prevention, and low friction torque
  - Oil seal is installed in small clearance on the fixed support side. A deep-groove ball bearing with a shield on both sides is used on the simple support side. This minimizes friction torque.
- Lock nut is provided.
  - A lock nut of fine grade finish is provided to fix the bearing with high precision.



## Support units

Accessories to use with ball screw are available in stock.

### Support unit categories

Application	Shape	Support side	Bearing in use	Bearing bore Bearing seat diameter
Small equipment, light load	WBK**-01 	Fixed support side	Angular contact ball bearing	$\phi 6 \sim \phi 25$
	WBK**S-01 	Simple support side	Deep groove ball bearing	$\phi 6 \sim \phi 25$
	WBK**SF-01 		Deep groove ball bearing	$\phi 12, \phi 15$ (Exclusive for VFA Series)
	WBK**R-01 (Support kit) 	Fixed support side	Deep groove ball bearing (arranged to have angular contact)	$\phi 4, \phi 6$ (Exclusive for RMA and RMS Series)
	WBK**-11 		Angular contact ball bearing	$\phi 6 \sim \phi 25$
Machine tools, heavy load	WBK**DF*-31 	Fixed support side	Thrust angular contact ball bearing	$\phi 17 \sim \phi 40$

## Support units

### ① Classification

Ball screw support units are classified into categories by their shape (Table I-6.6). Select the type that is appropriate for you to use.

### ② Features

- Short delivery time: Standardized items in stock

- Use most suitable bearings

On the fixed support side, the angular contact ball bearing is used. It has great rigidity and low friction torque which match the rigidity of the ball screw. The thrust angular contact ball bearing with high precision and great rigidity is another choice for the fixed support side.

- High dust prevention, and low friction torque

Oil seal is installed in small clearance on the fixed support side. A deep-groove ball bearing with a shield on both sides is used on the simple support side. This minimizes friction torque.

- Lock nut is provided.

A lock nut of fine grade finish is provided to fix the bearing with high precision.

Details for the new NSK Low Profile Support Units you will find on page 154 and following.

### ③ Reference number and applicable ball screw

(For light load) **WBK 08 S-01**

Support unit product code

Nominal size

Support side code No code:Fixed support side  
<sub>S</sub>SF:Simple support side  
 R:Fixed support side (support kit)

Design serial number

(For heavy load) **WBK 25 DF-31**

Nominal size

Bearing combination

DF (duplex), DFD (triplex), DFF (quadruple)

Design serial number

The table below show "shaft diameter/lead combinations" of standard ball screws that are applicable to support units.

### Support units for light load and applicable "shaft diameter/lead combinations"

Light load / small equipment	Support unit / reference number			"Shaft diameter/lead combinations" of standard ball screws that are applicable to support unit
	Square		Round	
	Fixed support side (driving motor side)	Simple support side (opposite to driving motor)	Fixed support side	
	WBK06-01A	—	WBK06-11	
WBK08-01A	WBK08S-01	WBK08-11	$\phi 8 \times 1$ , $\phi 8 \times 1.5$ , $\phi 8 \times 2$ , $\phi 10 \times 2$ , $\phi 10 \times 2.5$	
WBK10-01A	WBK10S-01	WBK10-11	$\phi 10 \times 4$ , $\phi 12 \times 2$ , $\phi 12 \times 2.5$ , $\phi 12 \times 5$ , $\phi 12 \times 10$	
WBK12-01A	WBK12S-01	WBK12-11	$\phi 14 \times 5$ , $\phi 14 \times 8$ , $\phi 15 \times 10$ , $\phi 15 \times 20$ , $\phi 16 \times 2$ $\phi 16 \times 2.5$ , $\phi 16 \times 5$ , $\phi 16 \times 16$ , $\phi 16 \times 32$	
WBK15-01A	WBK15S-01	WBK15-11	$\phi 20 \times 4$ , $\phi 20 \times 5$ , $\phi 20 \times 10$ , $\phi 20 \times 20$ , $\phi 20 \times 40$	
WBK20-01	WBK20S-01	WBK20-11	$\phi 20 \times 4$ , $\phi 20 \times 5$ , $\phi 20 \times 6$ , $\phi 20 \times 10$ , $\phi 20 \times 20$ $\phi 25 \times 25$ , $\phi 25 \times 50$ , $\phi 28 \times 5$ , $\phi 28 \times 6$	
WBK25-01	WBK25S-01	WBK25-11	$\phi 32 \times 5$ , $\phi 32 \times 6$ , $\phi 32 \times 8$ , $\phi 32 \times 10$ $\phi 32 \times 25$ , $\phi 32 \times 32$ ,	

- Remarks**
1. Reference number is based on the bearing bore on the fixed support side.
  2. Please note that the reference numbers 12 or below on the simple-support side do not match the bore of the deep-groove ball bearing in use.

### Support units for heavy load and applicable "shaft diameter/lead combinations"

Heavy load / machine tools	Support unit / reference number		"Shaft diameter/lead combinations" of standard ball screws that are applicable to the support unit
	Fixed support side (drive motor side)	Fixed support side (opposite to drive motor)	
WBK30DF-31	WBK25DF-31	$\phi 36 \times 10$	
WBK30DFD-31	WBK25DFD-31	$\phi 36 \times 10$ , $\phi 40 \times 10$	
WBK30DF-31	WBK30DF-31	$\phi 40 \times 5$ , $\phi 40 \times 8$ , $\phi 40 \times 10$ , $\phi 40 \times 12$	
WBK30DFD-31	WBK30DFD-31	$\phi 40 \times 12$	
WBK35DF-31	WBK35DF-31	$\phi 45 \times 10$	
WBK40DF-31	WBK40DF-31	$\phi 50 \times 10$	
WBK40DFD-31	WBK40DFD-31	$\phi 50 \times 10$	

**Dimensions of support unit for light load / small equipment**

The table shows characteristic value of the support units for light load / small equipment.

**Characteristic values of support units for light load**

Fixed side support unit							Support unit on simple support side		
Support unit reference number	Bearing in use (angular contact ball bearing)						Bearing in use (deep-groove ball bearing)		Support unit reference number
	Bearing reference number	Axial direction				Maximum starting torque N·cm	Bearing reference number	Radial direction	
		Basic dynamic load rating C <sub>r</sub> N	Load limit N	Preload N	Rigidity N/μm			Basic dynamic load rating C N	
WBK06-01A (Square) WBK06-11 (Round)	706ATYDFC7P5	2670	1040	17	28	0.49	—	—	—
WBK08-01A (Square) WBK08-11 (Round)	708ATYDFC8P5	4400	1450	59	53	0.88	606ZZ	2260	WBK08S-01 (Square)
WBK10-01A (Square) WBK10-11 (Round)	7000ATYDFC8P5	6600	2730	200	94	1.9	608ZZ	3300	WBK10S-01 (Square)
WBK12-01A (Square) WBK12-11 (Round)	7001ATYDFC8P5	7150	3040	215	104	2.1	6000ZZ	4550	WBK12S-01 (Square)
WBK15-01A (Square) WBK15-11 (Round)	7002ATYDFC8P5	7600	3370	235	113	2.3	6002ZZ	5600	WBK15S-01 (Square)
WBK20-01 (Square) WBK20-11 (Round)	7204ATYDFC8P5	17900	8260	440	155	5.4	6204ZZ	12800	WBK20S-01 (Square)
WBK25-01 (Square) WBK25-11 (Round)	7205ATYDFC8P5	20200	10000	580	192	7.2	6205ZZ	14000	WBK25S-01 (Square)

**Square type Reference number: WBK06-01A**

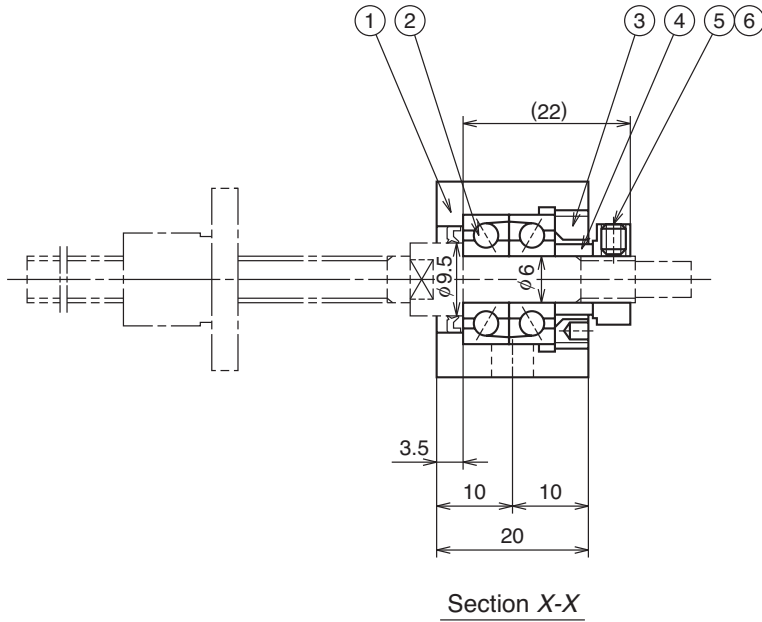

**Round type Reference number: WBK06-11**

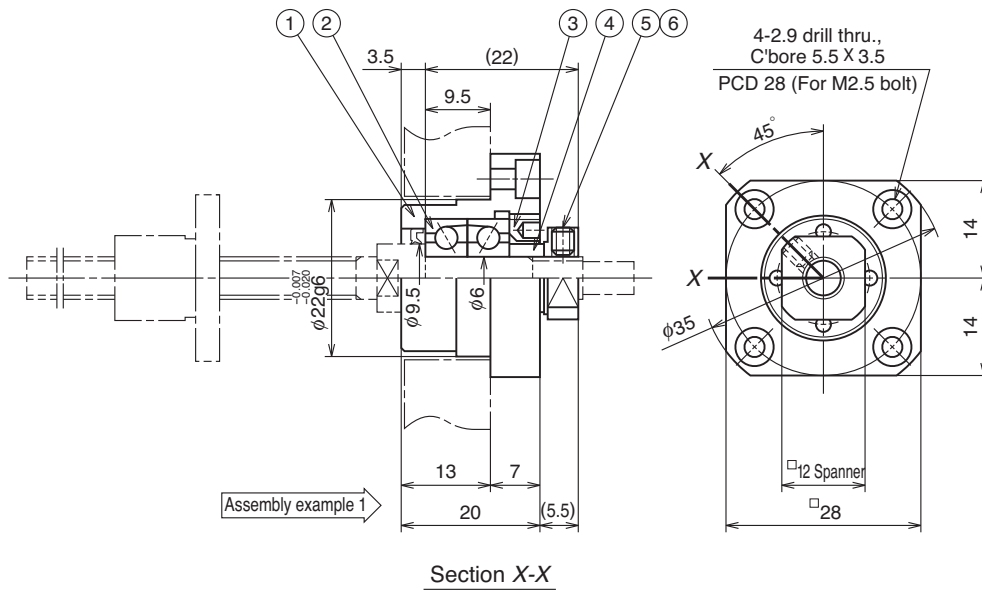

**WBK06**



Unit: mm

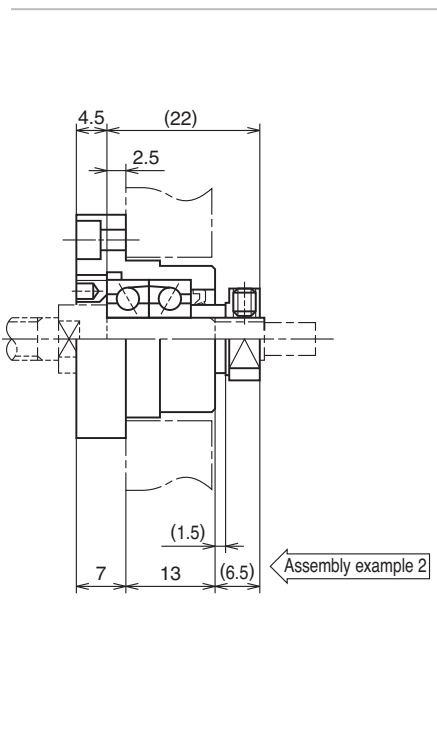
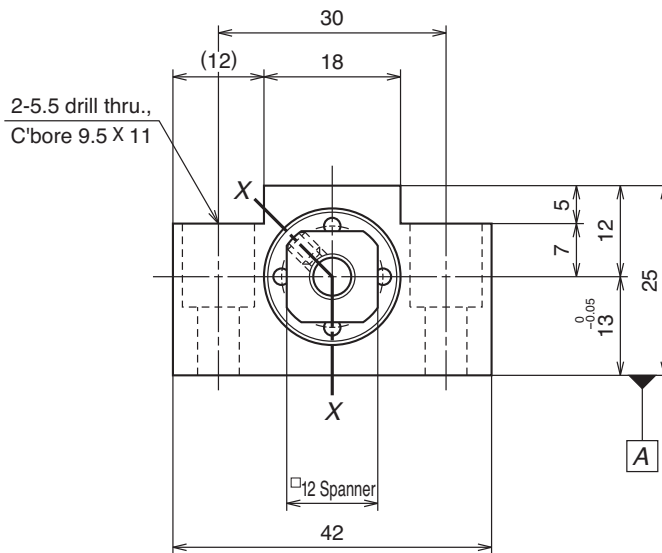

**Parts list**

Number	Name of part	Quantity	Remarks
①	Bearing housing	1	With oil seal
②	Bearing	One set	706ATYDFC7P5
③	Retaining cover	1	
④	Spacer	1	
⑤	Lock nut	1	For M6, tightening torque 245N·cm (25kgf·cm)
⑥	Set screw	1	M3, with a set piece (pad)

- Remarks**
1. When installing a square support unit, place A side to the base. Use a spacer if necessary to adjust height.
  2. Components ①, ②, ③ are assembled into a unit. Do not disassemble.
  3. An appropriate volume of grease is packed in the support unit.
  4. Tighten the set screw ⑥ after adjustment.



**Square type Reference number: WBK08-01A (fixed support side); WBK08S-01 (simple support side)**

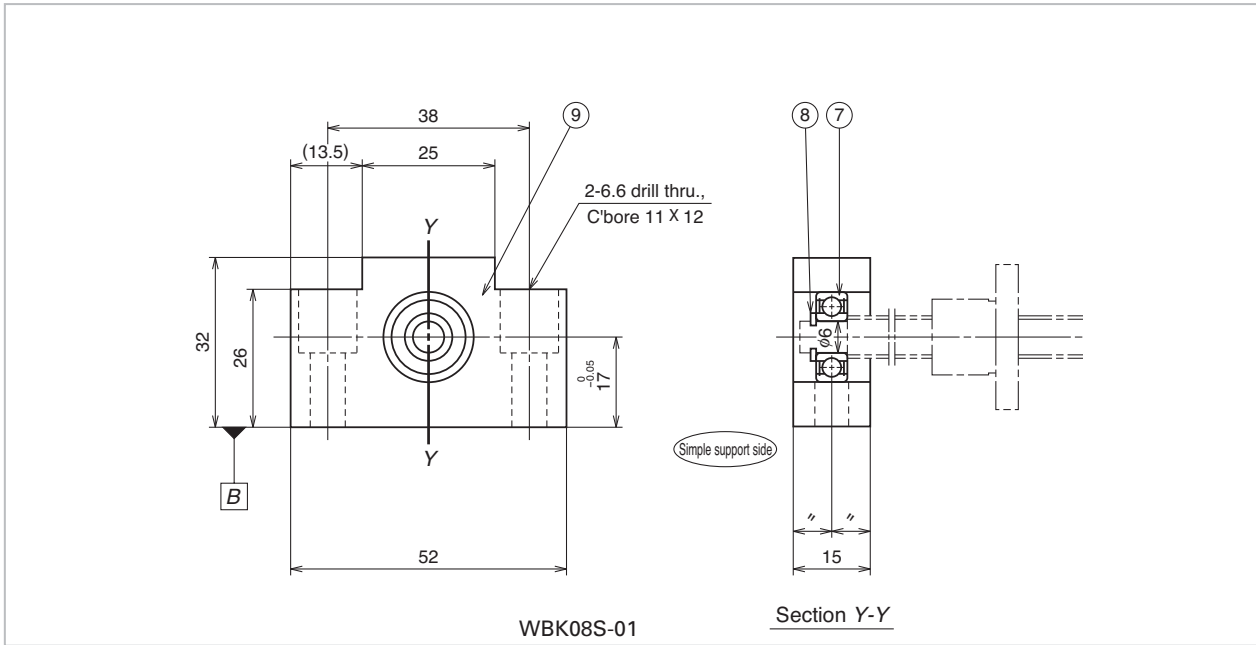

**Round type Reference number: WBK08-11**

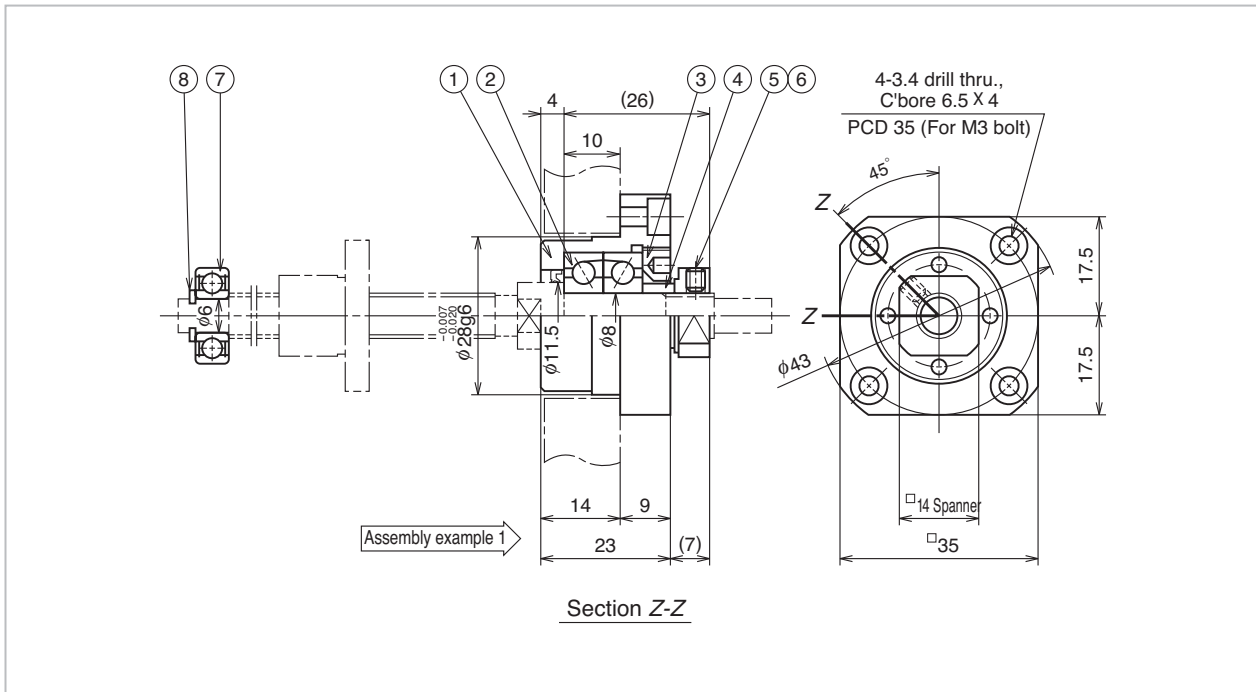

**WBK08**

Unit: mm

Standard stock

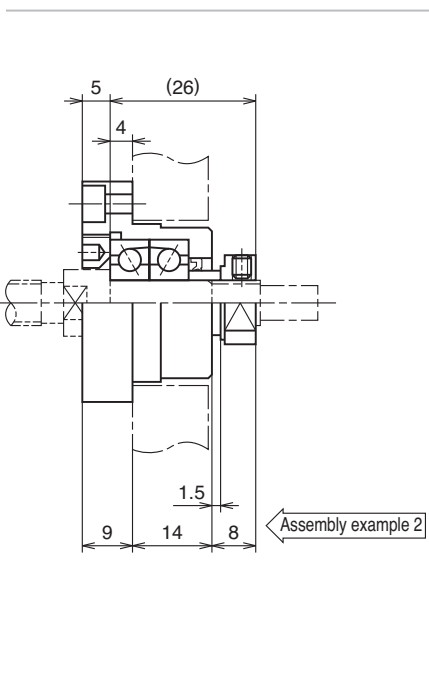
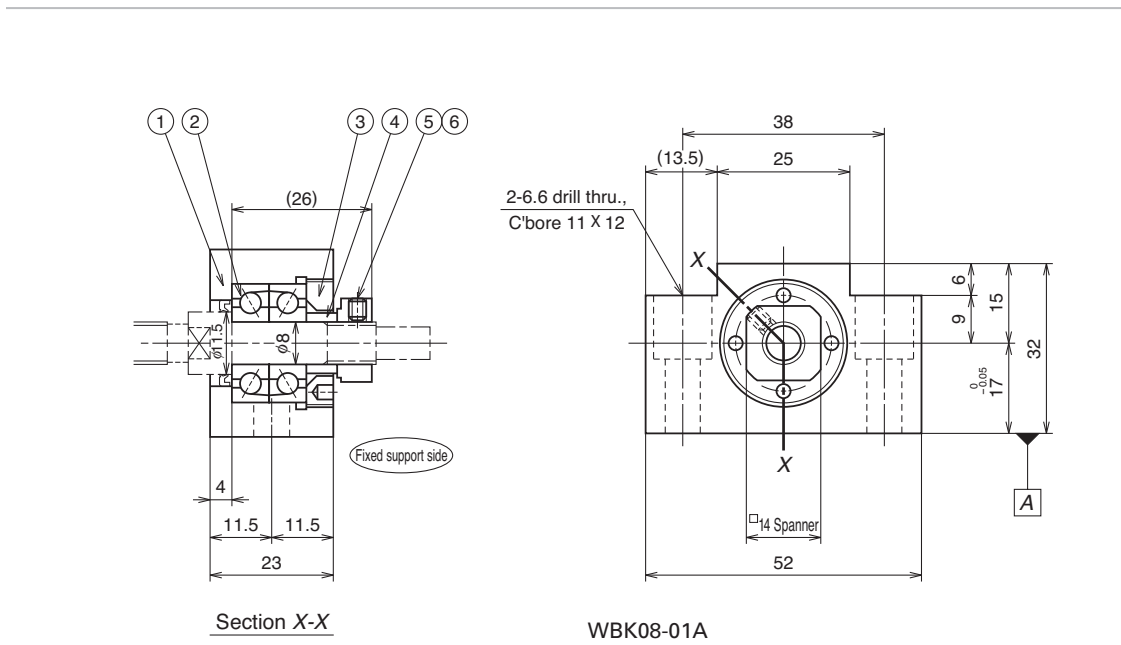

**Parts list**

Number	Name of part	Quantity	Remarks
①	Bearing housing	1	With oil seal on fixed support side
②	Bearing	One set	706ATYDFC7P5
③	Retaining cover	1	
④	Spacer	1	
⑤	Lock nut	1	For M8, tightening torque 490N·cm {50 kgf·cm}
⑥	Set screw	1	M3, with a set piece (pad)
⑦	Bearing	1	606ZZ
⑧	Retaining ring	1	
⑨	Bearing housing	1	Simple support side (only square type)

- Remarks**
1. When installing a square support unit, place A and B sides to the base. Use a spacer if necessary to adjust height.
  2. Components ①, ②, ③ are assembled into a unit. Do not disassemble.
  3. An appropriate volume of grease is packed in the support unit.
  4. Tighten the set screw ⑥ after adjustment.

## Square type Reference number: WBK10-01A (fixed support side); WBK10S-01 (simple support side)

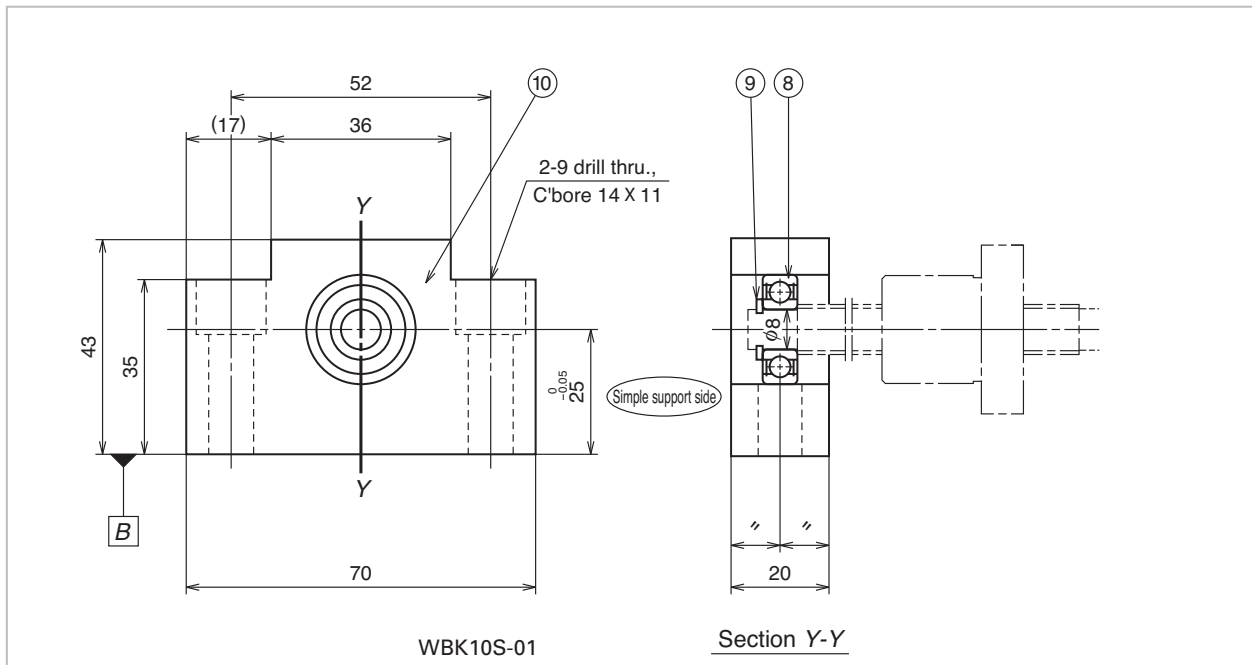

## Round type Reference number: WBK10-11

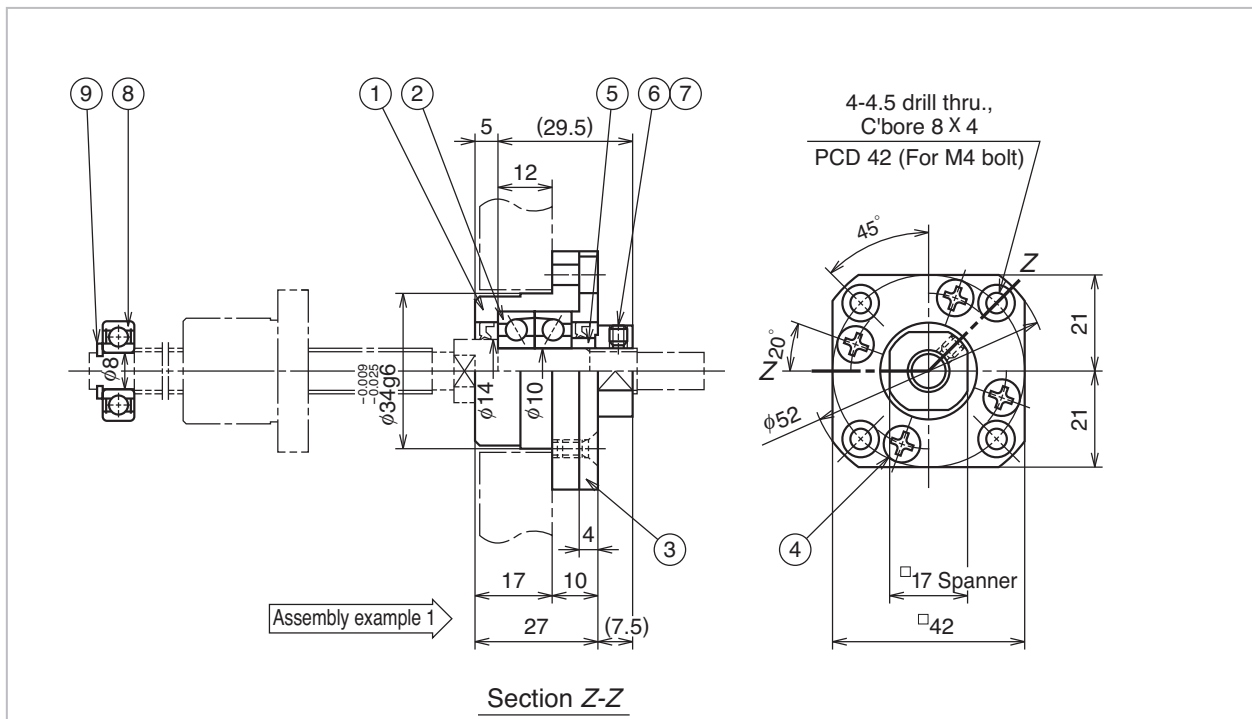

**WBK10**



Unit: mm

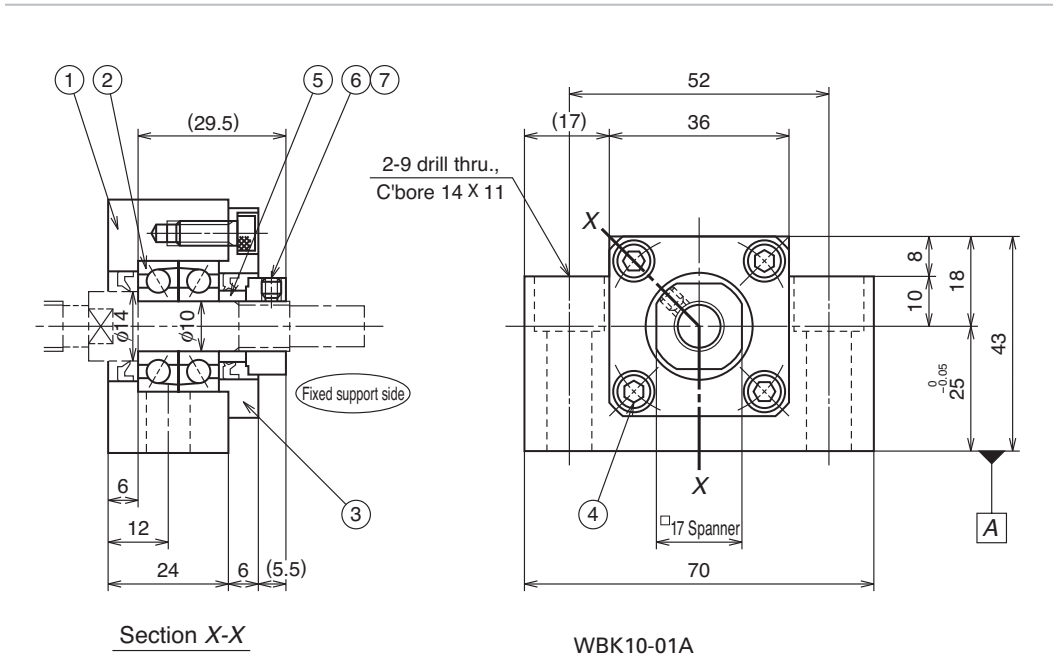

**Parts list**

Number	Name of part	Quantity	Remarks
①	Bearing housing	1	With oil seal on fixed support side
②	Bearing	One set	7000ATYDFC8P5
③	Retaining cover	1	
④	Hexagon socket head cap screw or cross recessed pan head screw	4	M4
⑤	Spacer	1	
⑥	Lock nut	1	For M10, tightening torque 930N·cm {95 kgf·cm}
⑦	Set screw	1	M4 with a set piece (pad)
⑧	Bearing	1	608ZZ
⑨	Retaining ring	1	
⑩	Bearing housing	1	Simple support side (only square type)

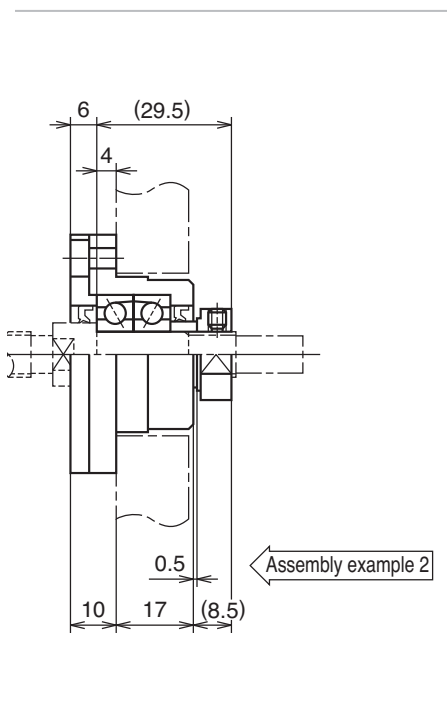

- Remarks**
1. When installing a square support unit, place A and B sides to the base. Use a spacer if necessary to adjust height.
  2. Components ①, ②, ③ are assembled into a unit. Do not disassemble.
  3. An appropriate volume of grease is packed in the support unit.
  4. Tighten the set screw ⑦ after adjustment.

**Square type Reference number: WBK12-01 (fixed support side); WBK12S-01 (simple support side)**

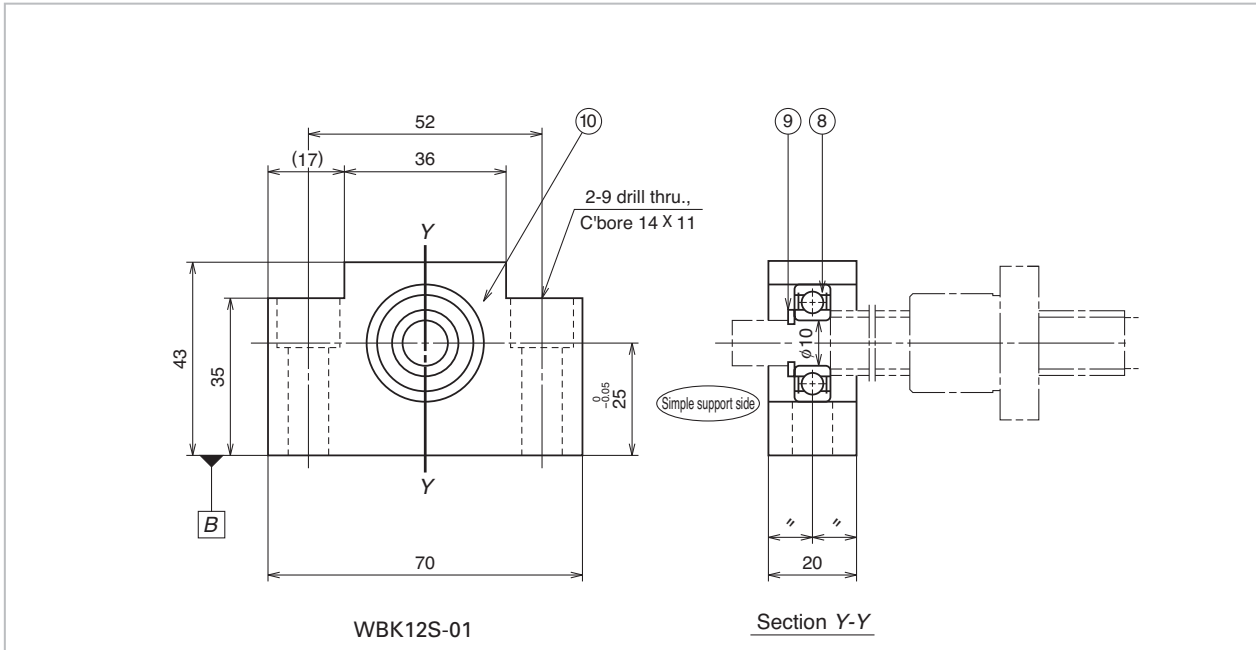

**Round type Reference number: WBK12-11**

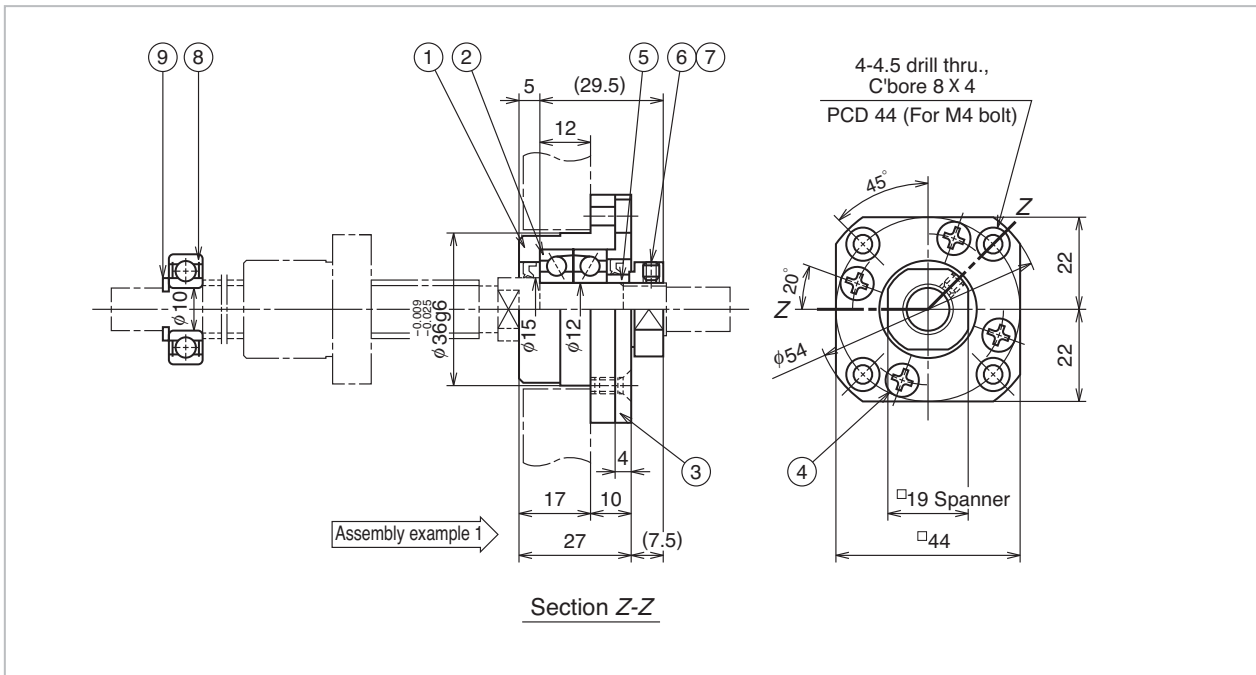

WBK12



Unit: mm

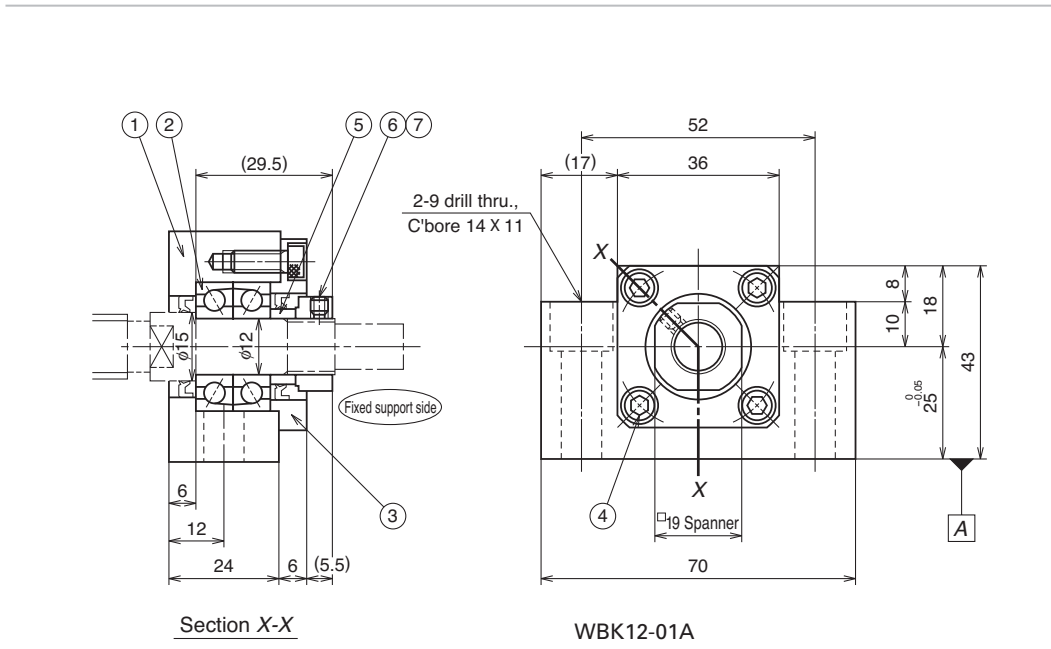

Section X-X

WBK12-01A

Parts list

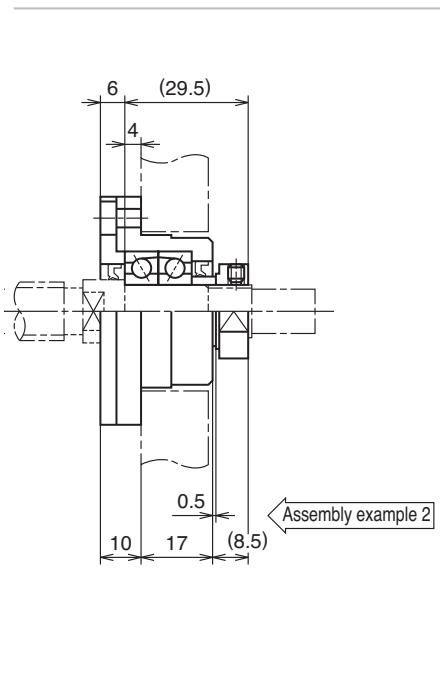

Number	Name of part	Quantity	Remarks
①	Bearing housing	1	With oil seal on fixed support side
②	Bearing	One set	7001ATYDFC8P5
③	Retaining cover	1	
④	Hexagon socket head cap screw or cross recessed pan head screw	4	M4
⑤	Spacer	1	
⑥	Lock nut	1	For M12, tightening torque 1370N•cm {140 kgf•cm}
⑦	Set screw	1	M4 with a set piece (pad)
⑧	Bearing	1	6000ZZ
⑨	Retaining ring	1	
⑩	Bearing housing	1	Simple support side (only square type)

- Remarks**
1. When installing a square support unit, place A and B sides to the base. Use a spacer if necessary to adjust height.
  2. Components ①, ②, ③ are assembled into a unit. Do not disassemble.
  3. An appropriate volume of grease is packed in the support unit.
  4. Tighten the set screw ⑦ after adjustment.

**Square type Reference number: WBK15-01A (fixed support side); WBK15-01 (simple support side)**

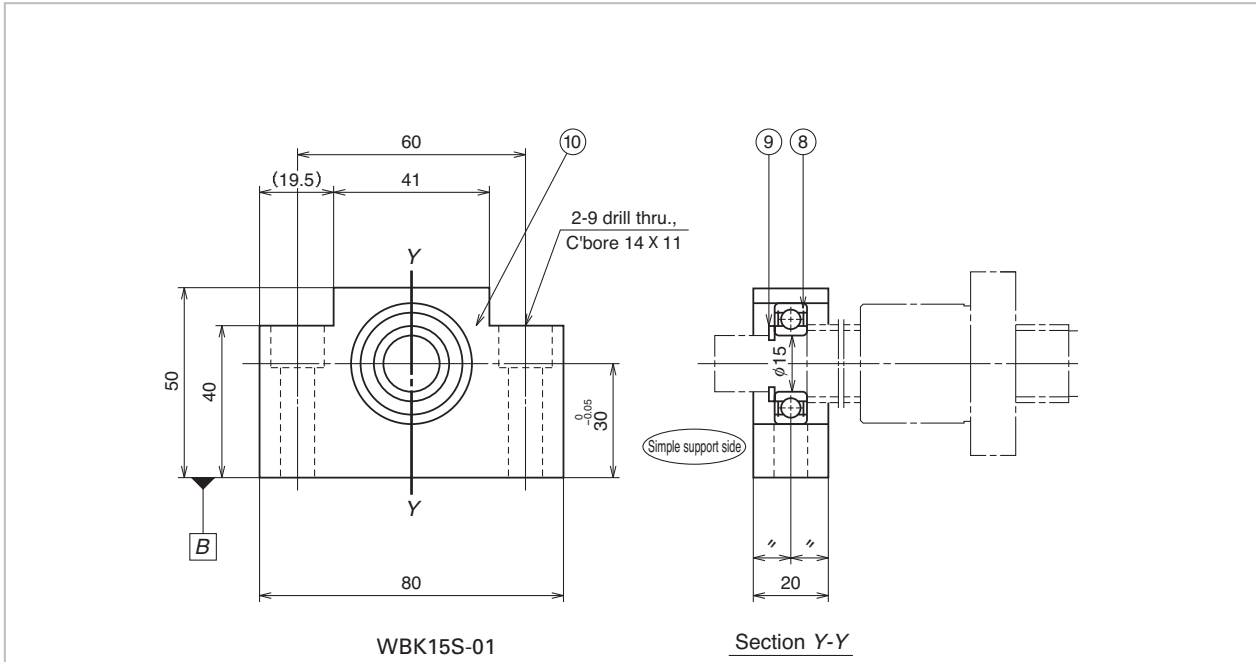

**Round type Reference number: WBK15-11**

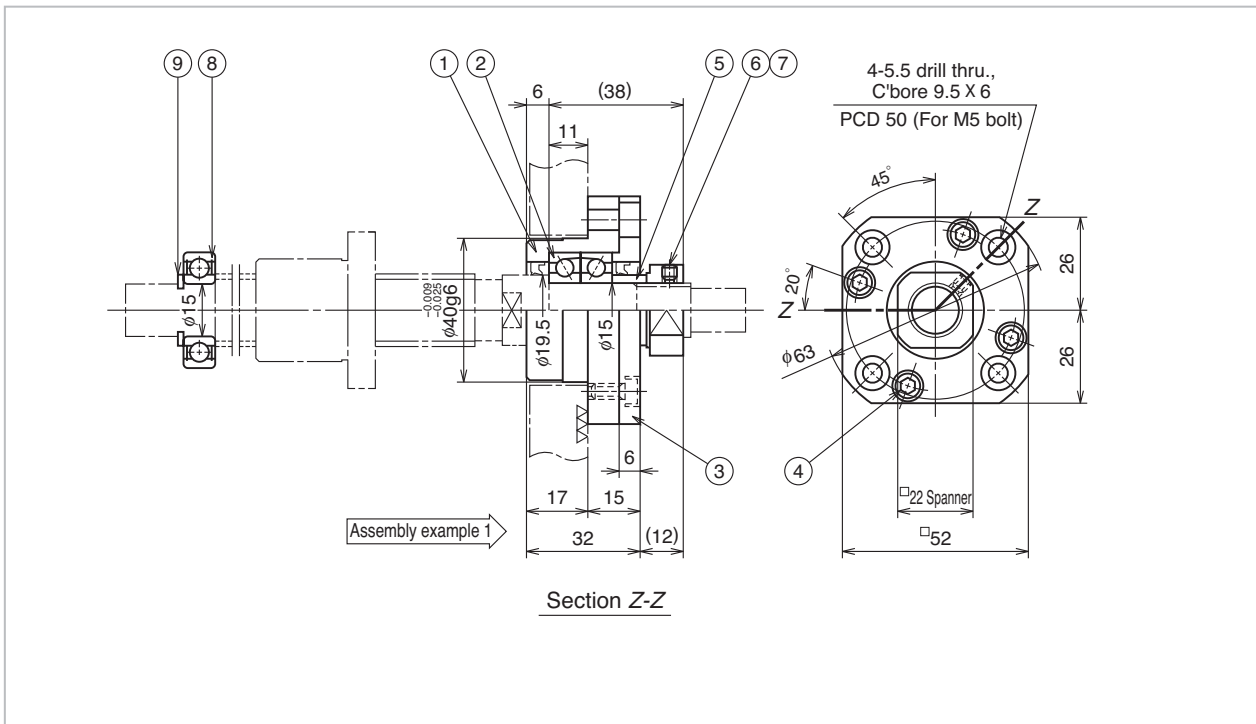



## WBK15

Standard  
stock

Unit: mm

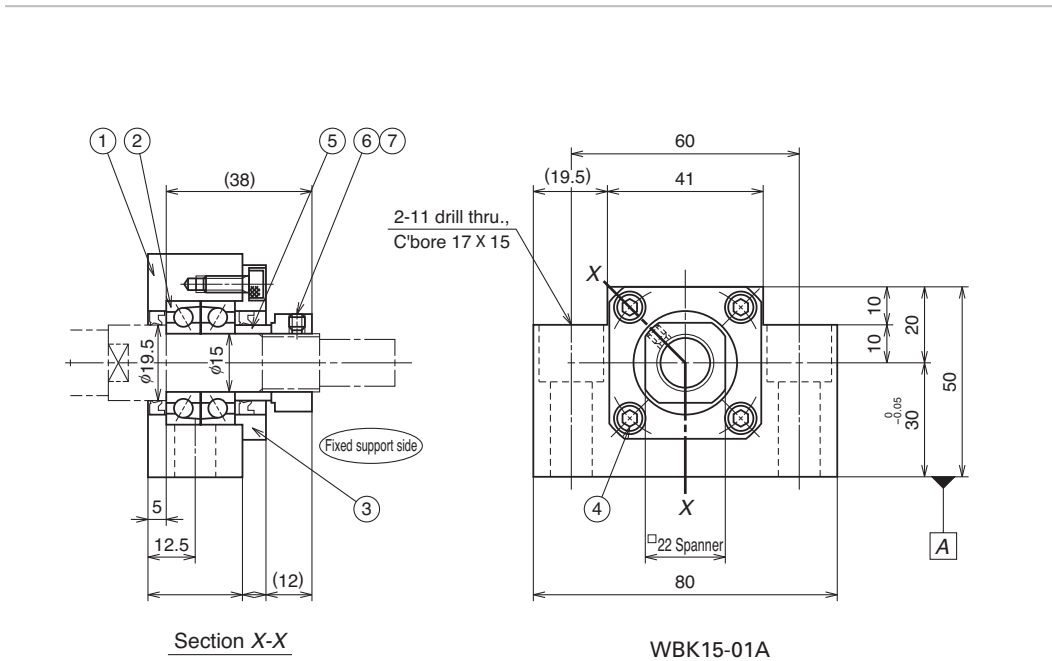

## Parts list

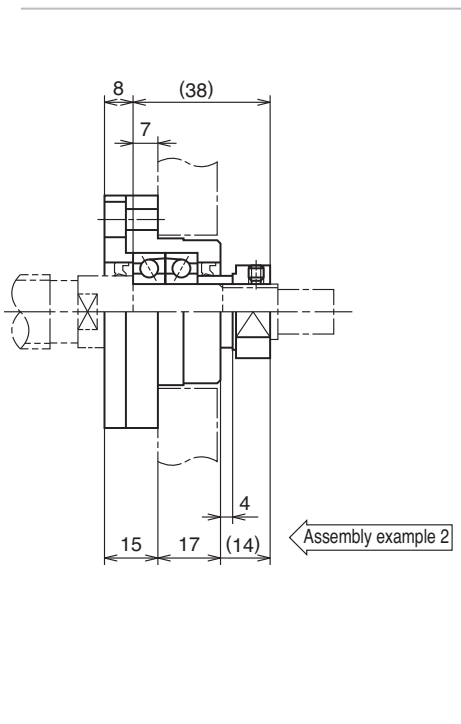

Number	Name of part	Quantity	Remarks
①	Bearing housing	1	With oil seal on fixed support side
②	Bearing	One set	7002ATYDFC8P5
③	Retaining cover	1	
④	Hexagon socket head cap screw	4	M4
⑤	Spacer	1	
⑥	Lock nut	1	For M15, tightening torque 2350N•cm {240 kgf•cm}
⑦	Set screw	1	M4 with a set piece (pad)
⑧	Bearing	1	6002ZZ
⑨	Retaining ring	1	
⑩	Bearing housing	1	Simple support side (only square type)

- Remarks**
1. When installing a square support unit, place A and B sides to the base. Use a spacer if necessary to adjust height.
  2. Components ①, ②, ③ are assembled into a unit. Do not disassemble.
  3. An appropriate volume of grease is packed in the support unit.
  4. Tighten the set screw ⑦ after adjustment.

**Square type Reference number: WBK20-01 (fixed support side); WBK20S-01 (simple support side)**

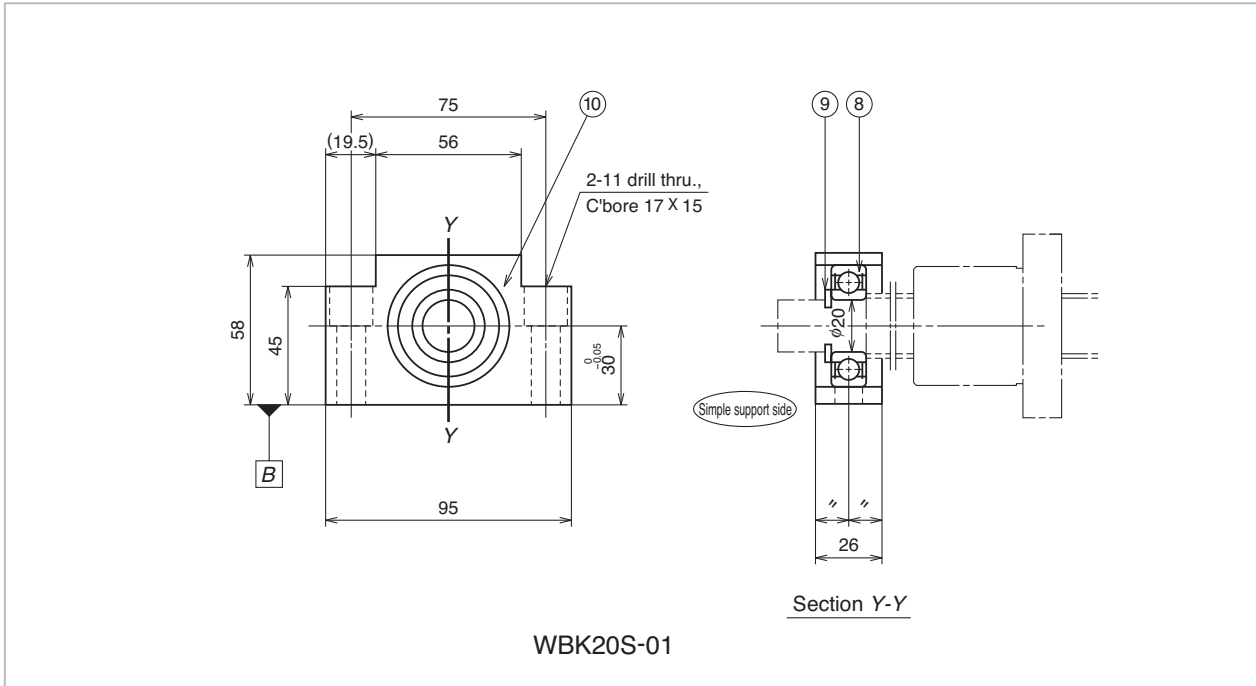

**Round type Reference number: WBK20-11**

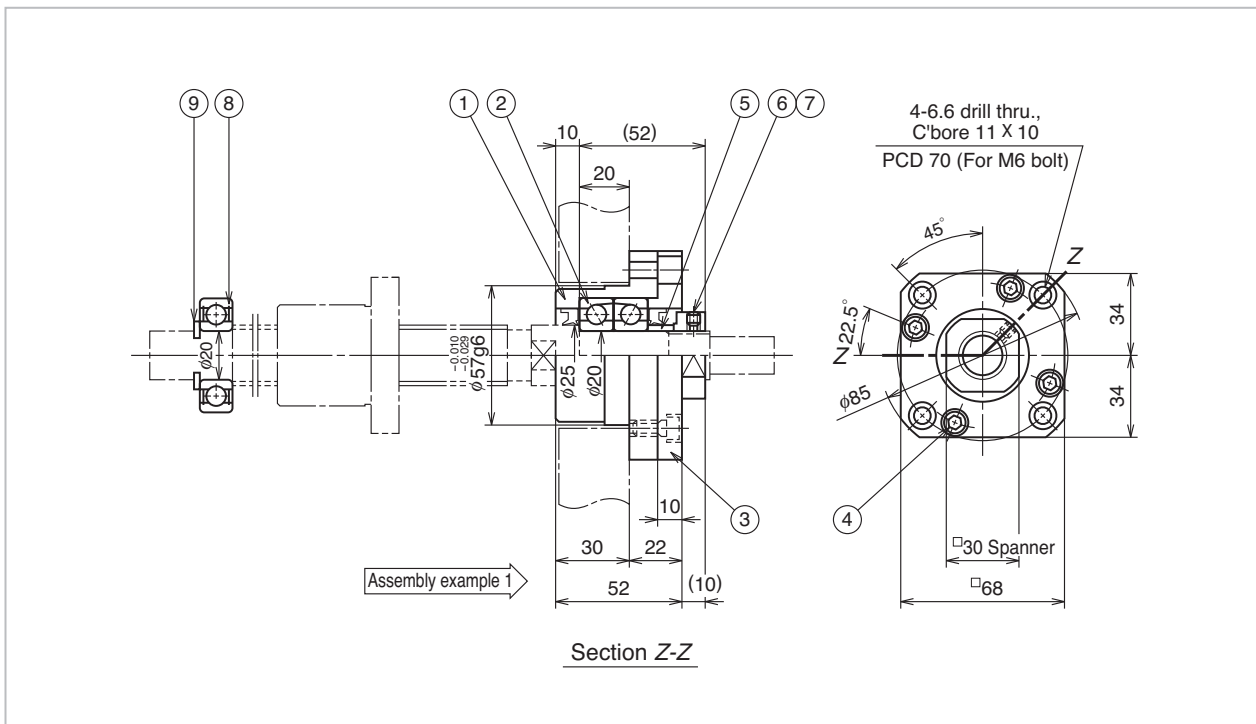

**WBK20**



Unit: mm

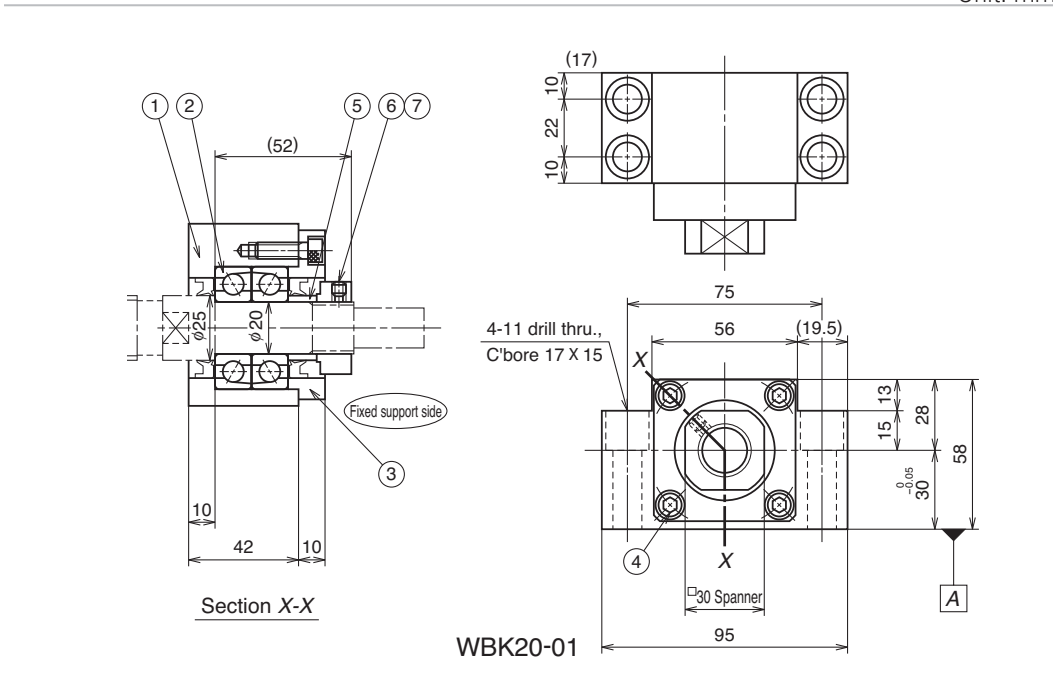

WBK20-01

**Parts list**

Number	Name of part	Quantity	Remarks
①	Bearing housing	1	With oil seal on fixed support side
②	Bearing	One set	7204ATYDFC8P5
③	Retaining cover	1	
④	Hexagon socked head cap screw	4	M6
⑤	Spacer	1	
⑥	Lock nut	1	For M20, tightening torque 4700N·cm {480 kgf·cm}
⑦	Set screw	1	M4 with a set piece (pad)
⑧	Bearing	1	6204ZZ
⑨	Retaining ring	1	
⑩	Bearing housing	1	Simple support side (only square type)

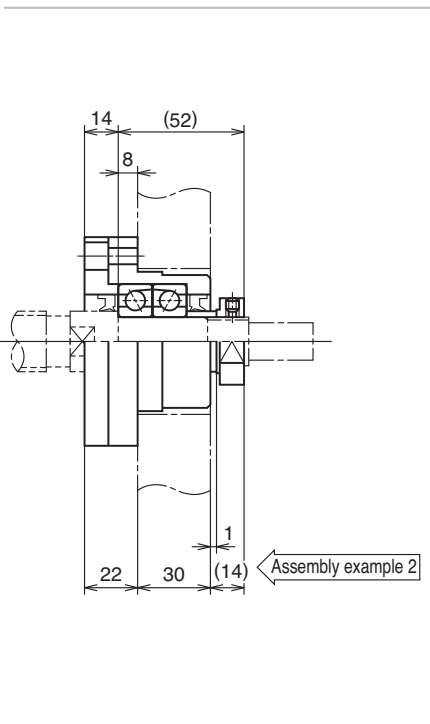

- Remarks**
1. When installing a square support unit, place A and B sides to the base. Use a spacer if necessary to adjust height.
  2. Components ①, ②, ③ are assembled into a unit. Do not disassemble.
  3. An appropriate volume of grease is packed in the support unit.
  4. Tighten the set screw ⑦ after adjustment.

**Square type Reference number: WBK25-01 (fixed support side); WBK25S-01 (simple support side)**

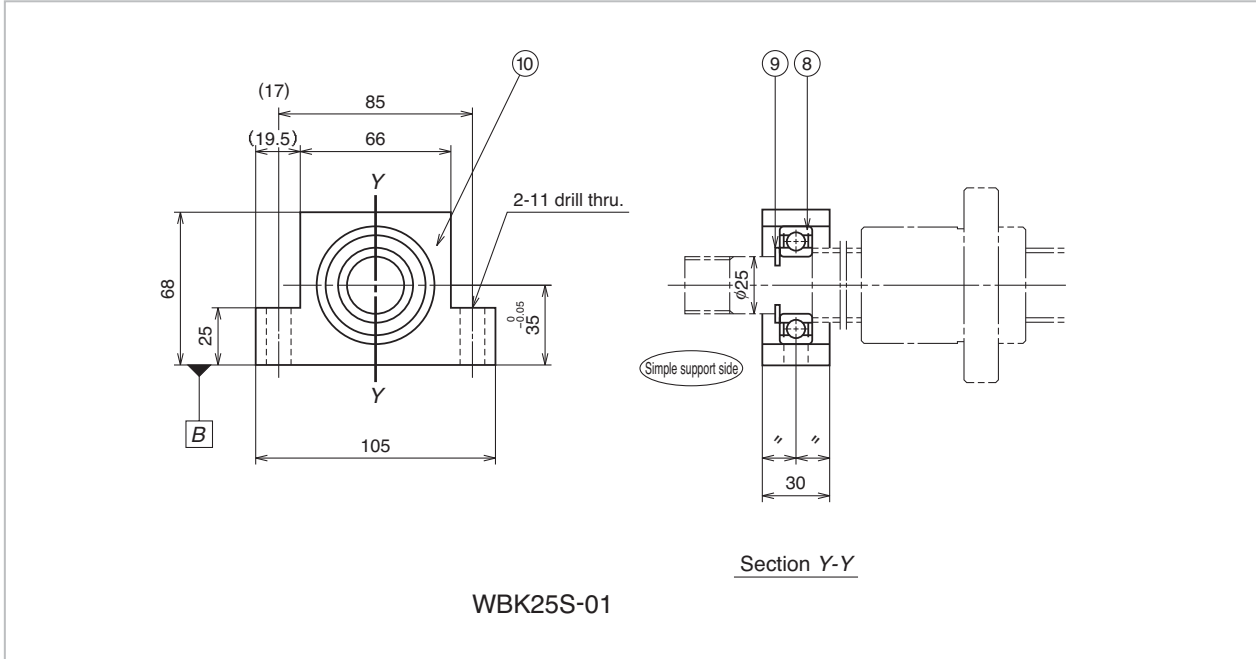

**Round type Reference number: WBK25-11**

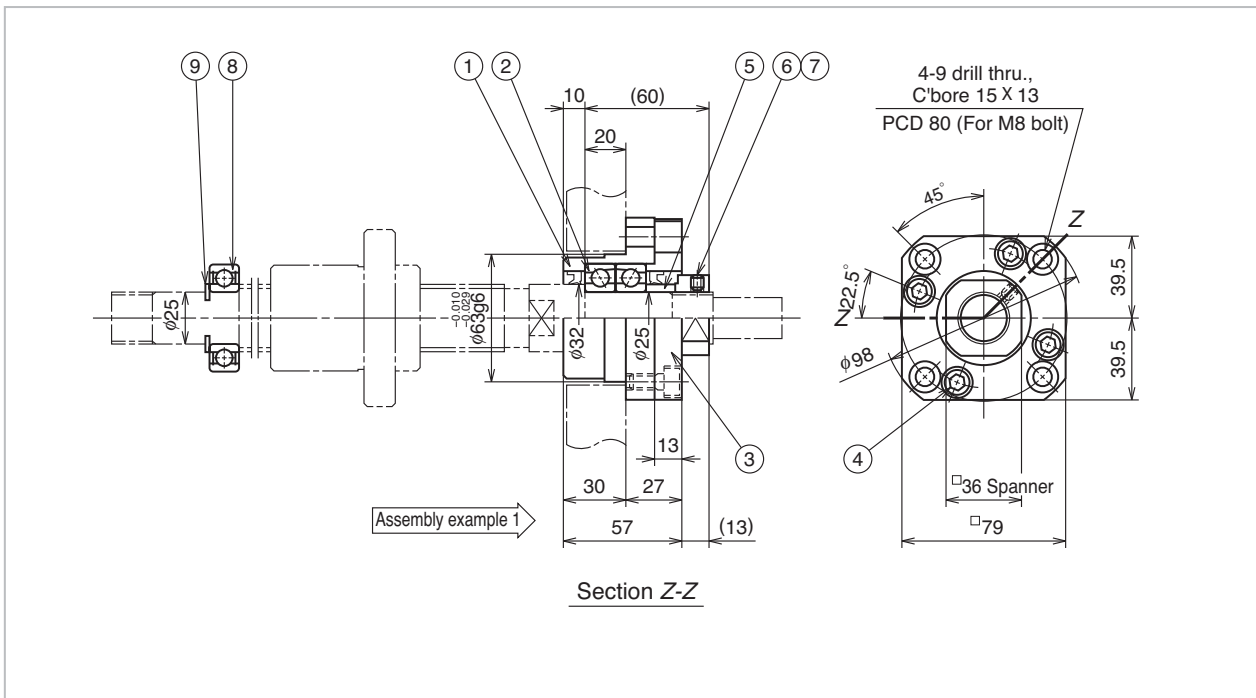

**WBK25**



Unit: mm

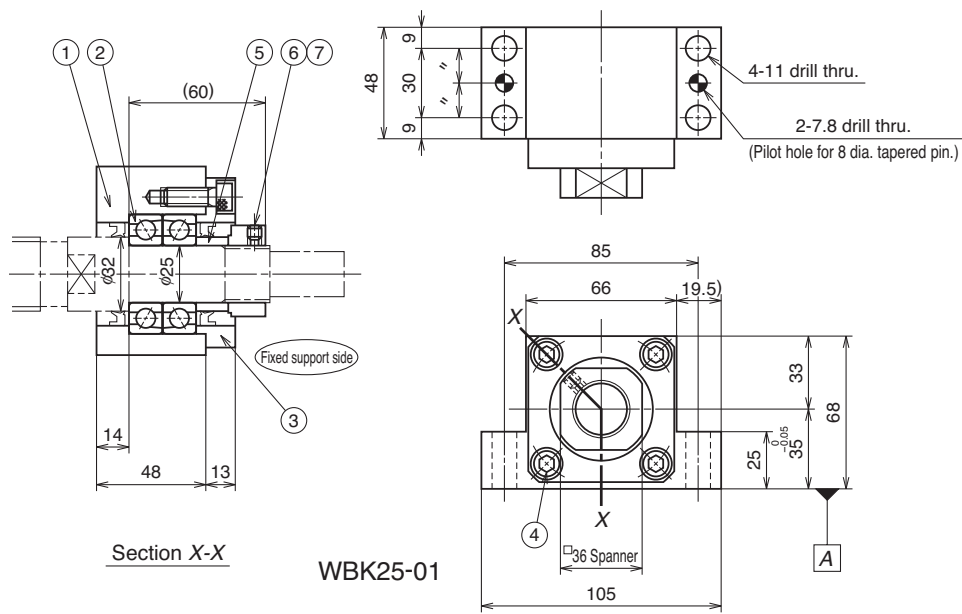

WBK25-01

**Parts list**

Number	Name of part	Quantity	Remarks
①	Bearing housing	1	With oil seal on fixed support side
②	Bearing	One set	7204ATYDFC8P5
③	Retaining cover	1	
④	Hexagon socketed head cap screw	4	M6
⑤	Spacer	1	
⑥	Lock nut	1	For M25, tightening torque 8400N·cm {860 kgf·cm}
⑦	Set screw	1	M6 with a set piece (pad)
⑧	Bearing	1	6205ZZ
⑨	Retaining ring	1	
⑩	Bearing housing	1	Simple support side (only square type)

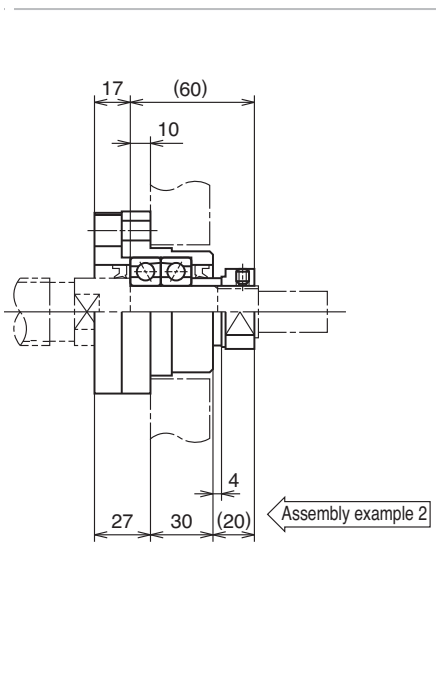

- Remarks**
1. When installing a square support unit, place A and B sides to the base. Use a spacer if necessary to adjust height.
  2. Components ①, ②, ③ are assembled into a unit. Do not disassemble.
  3. An appropriate volume of grease is packed in the support unit.
  4. Tighten the set screw ⑦ after adjustment.

**Square type Reference number: WBK12SF-01 (Simple support side: For VFA1210)**

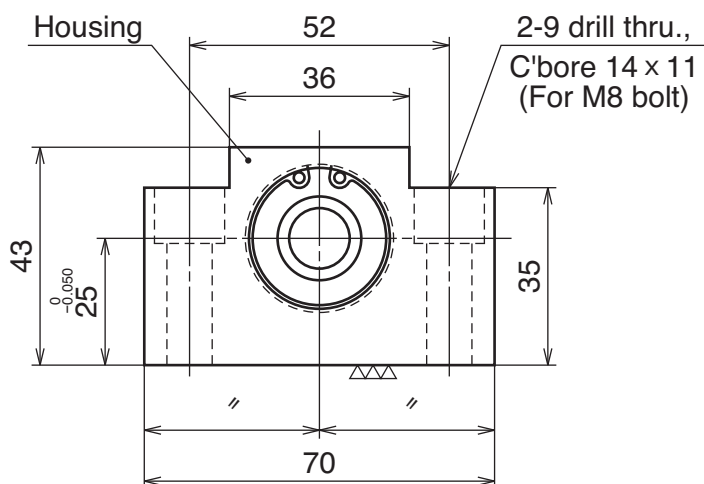

**Square type Reference number: WBK15SF-01 (Simple support side: For VFA1510)**

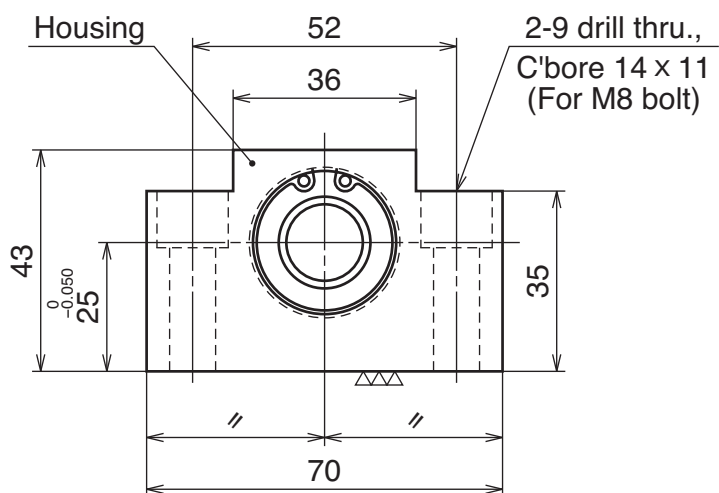

## WBK12SF



Unit: mm

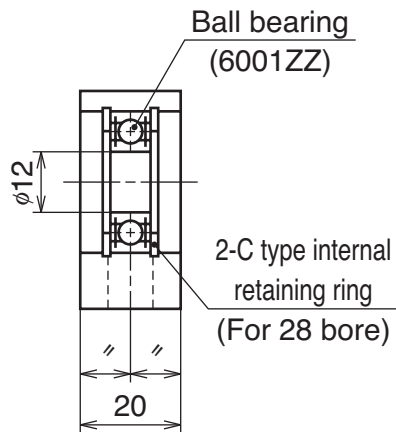

## Parts list (WBK12SF-01)

Number	Name of part	Quantity	Remarks
①	Bearing housing	1	Simple support side
②	Bearing	1	6001ZZ
③	Retaining ring	2	

**Remarks** 1. When installing the square support unit, place side A to the base and install the unit in the vertical direction. Use a spacer if necessary to adjust height.  
 2. Do not disassemble the support unit.  
 3. An appropriate volume of grease is packed in the bearing.

Applicable ball screw : VFA1210

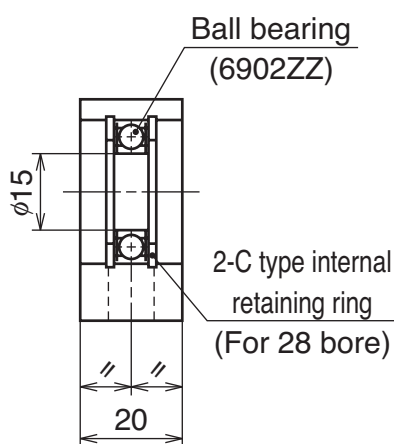

## Parts list (WBK15SF-01)

Number	Name of part	Quantity	Remarks
①	Bearing housing	1	Simple support side
②	Bearing	1	6902ZZ
③	Retaining ring	2	

**Remarks** 1. When installing the square support unit, place side A to the base and install the unit in the vertical direction. Use a spacer if necessary to adjust height.  
 2. Do not disassemble the support unit.  
 3. An appropriate volume of grease is packed in the bearing.

Applicable ball screw : VFA1510, VFA1520



**Round type Reference number: WBK04R-11**

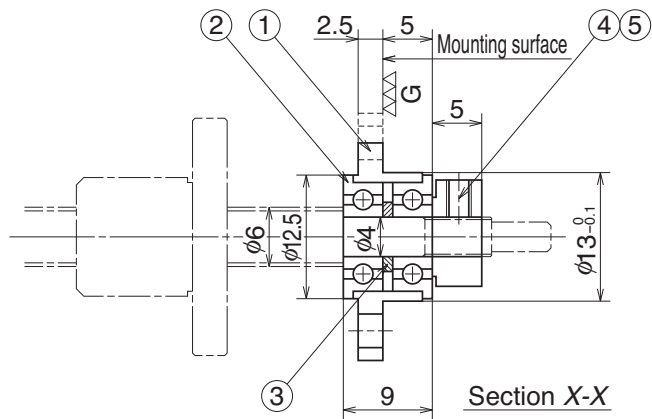

**Round type Reference number: WBK06R-11**

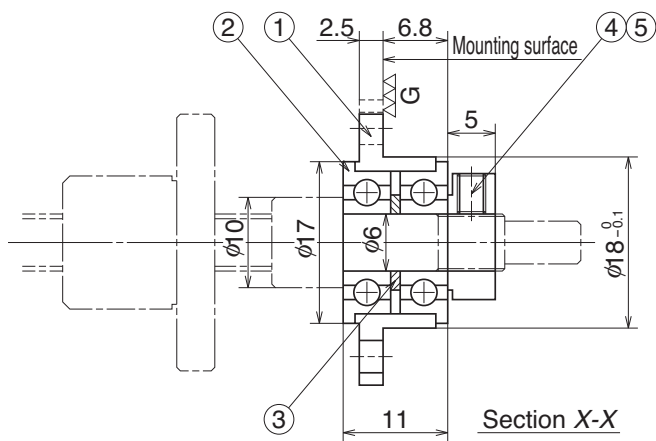

WBK\*\*R

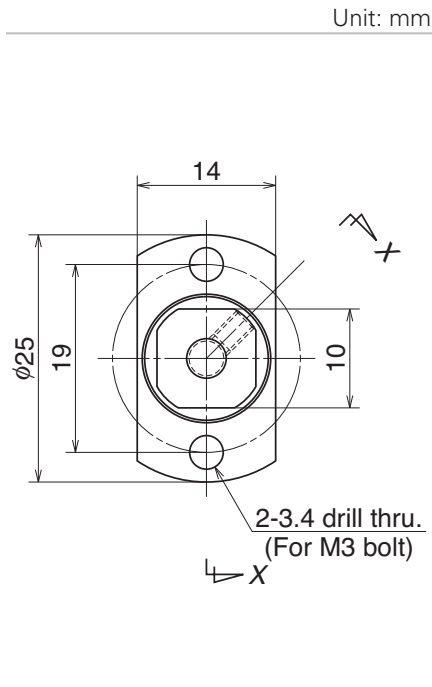

## Parts list (WBK04R-11)

Number	Name of part	Quantity	Remarks
①	Bearing housing	1	
②	Bearing	One set	F694ZZ
③	Spacer	1	
④	Lock nut	1	For M4, tightening torque 98N·cm {10 kgf·cm}
⑤	Set screw to secure the lock nut	1	M2.5 with a set piece (pad)

- Remarks**
1. Adjust phases of the bearing and the lock nut at time of assembly, and secure them in the state when the run out of the flange mounting surface is minimal.
  2. Assembled to an arbor (M4 bolt, nut) at time of delivery. Remove it from the arbor and move to the ball screw shaft end before use.
  3. An appropriate volume of grease is packed into the bearing.
  4. Slightly tighten the set screw ⑤ after adjustment.

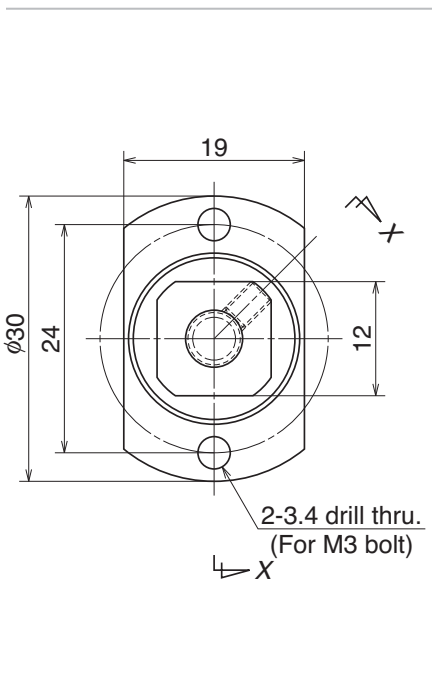
Applicable ball screw : **RMA0601**

## Parts list (WBK06R-11)

Number	Name of part	Quantity	Remarks
①	Bearing housing	1	
②	Bearing	One set	F696ZZ
③	Spacer	1	
④	Lock nut	1	For M6, tightening torque 118N·cm {12 kgf·cm}
⑤	Set screw to secure the lock nut	1	M2.5 with a set piece (pad)

- Remarks**
1. Adjust phases of the bearing and the lock nut at time of assembly, and secure them in the state when the run out of the flange mounting surface is minimal.
  2. Assembled to an arbor (M6 bolt, nut) at time of delivery. Remove it from the arbor and move to the ball screw shaft end before use.
  3. An appropriate volume of grease is packed into the bearing.
  4. Slightly tighten the set screw ⑤ after adjustment.

Applicable ball screw : **RMA0801, RMA0801.5, RMA0802**

### When using with a rolled ball screw

When using a support unit (for small equipment) for a rolled ball screw, install a spacer for holding a seal in the ball screw side of the shaft end.

The table shows the dimensions of spacer. NSK will provide the spacers on request. Use the reference number in the table, and place an order separately.

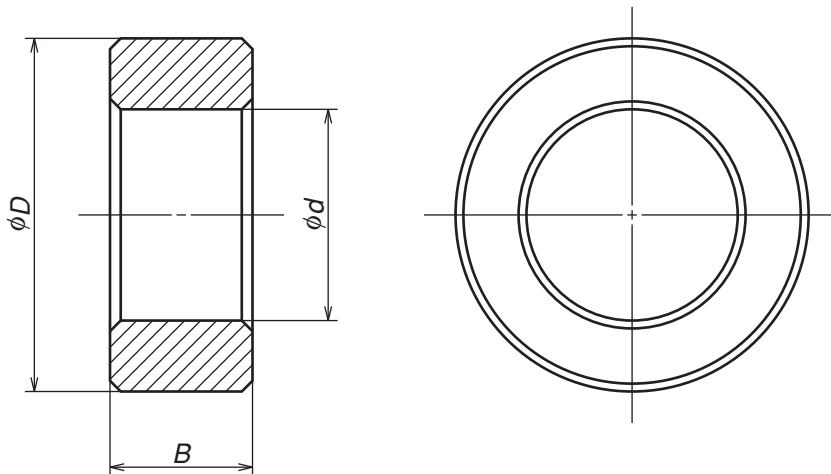

**Drawing of support unit spacer**

**Dimensions of support unit spacer**

Unit: mm

Spacer reference number	Dimensions			Applicable support unit reference number
	Internal diameter $d$	Outside diameter $D$	Width $B$	
WBK06K	6	9.5	5.0	WBK06-**
WBK08K	8	11.5	5.5	WBK08-**
WBK10K	10	14.5	5.5	WBK10-**
WBK12K	12	15.0	5.6	WBK12-**
WBK15K	15	19.5	10.0	WBK15-**
WBK20K	20	25.5	11.0	WBK20-**
WBK25K	25	32.0	14.0	WBK25-**

## (2) Dimensions of support unit: heavy-load / for machine tools

Support units for heavy-load / machine tools use a thrust angular contact ball bearing (TAC Series) with high rigidity and accuracy. The thrust angular contact ball bearing has very suitable functions and structure as a ball screw support bearing. There are three combinations as shown below.

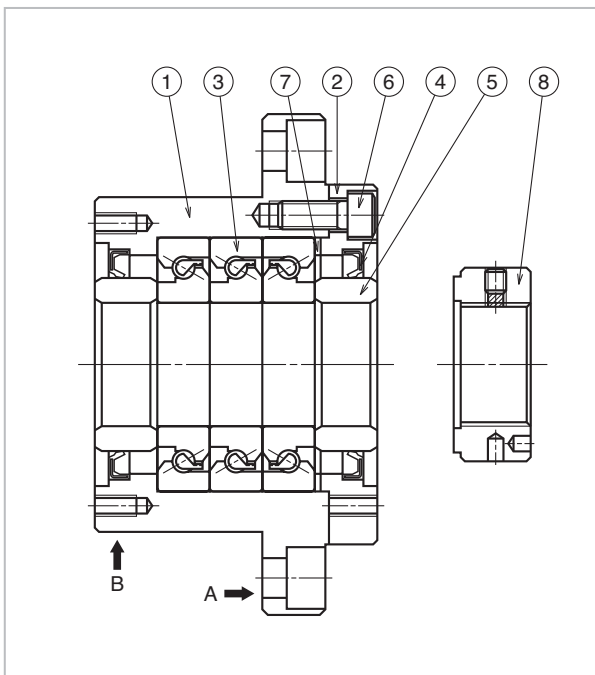
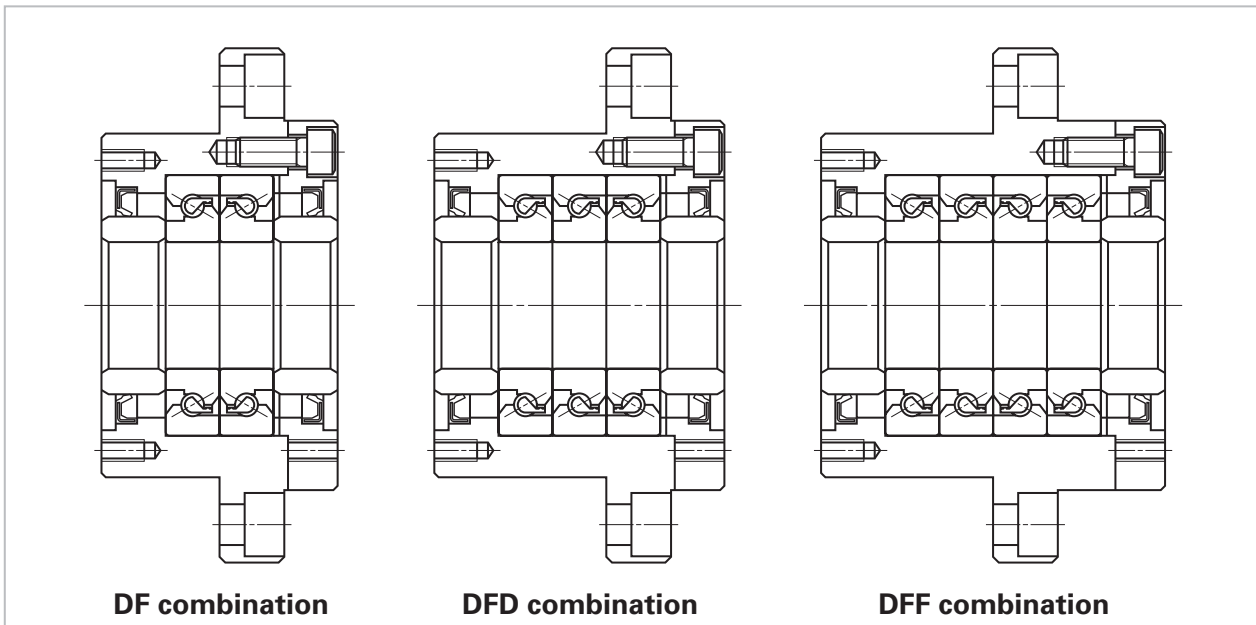

### Parts list

Part number	Part name	Quantity
①	Housing	1
②	Retaining cover	1
③	High accuracy thrust angular contact ball bearing	One set
④	Dust seal	2
⑤	Collar	2
⑥	Preload bolt	6 or 8
⑦	Shim	One set
⑧	Lock nut	1

### Remarks

1. Mount sections A and B to the machine base.
2. NSK support units are precisely preloaded and adjusted. Components ①, ②, ③, ④, ⑥, ⑦ are assembled into a unit. Do not disassemble.
3. Grease is packed into support units.
4. Lock nut ⑧ is exclusively prepared for ball screw. The end face of the nut is in strict control being precisely perpendicular to the V thread. Secure the lock nut using the set screw. Lock nut is also available as an accessory (See page 180. Refer to general catalogue E3161 "Precision Machine Components" for high precision thrust angular contact ball bearing (TAC Series).

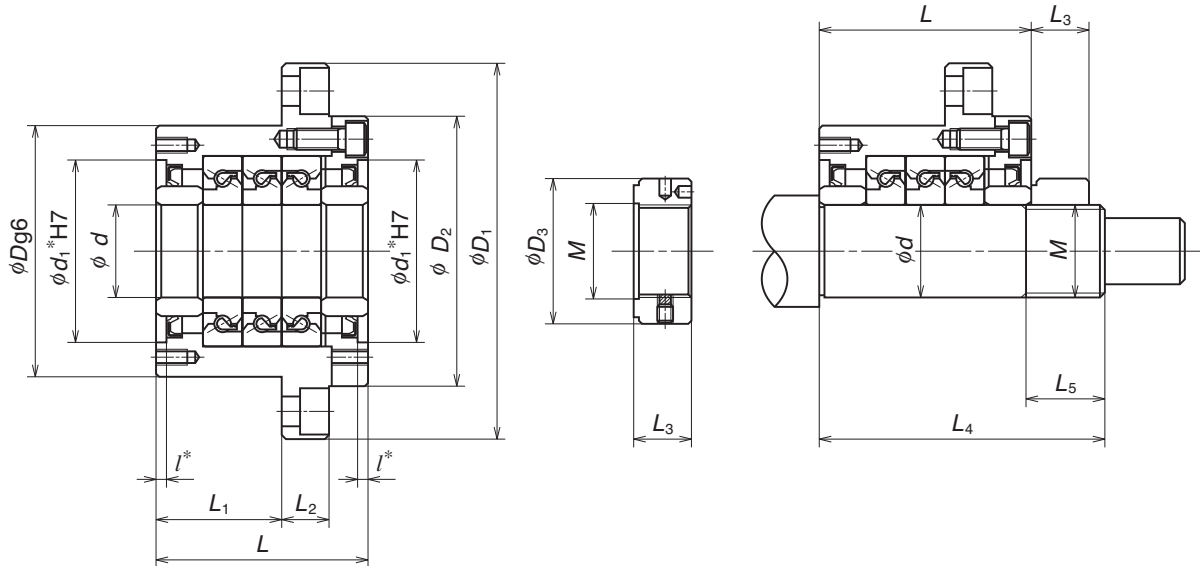

Lock nut

Dimensions of bearing seat

Support unit No.	Support unit																	Basic dynamic load rating $C_a$	
	$d$	$D$	$D_1$	$D_2$	$L$	$L_1$	$L_2$	$A$	$W$	$X$	$Y$	$Z$	$d_1^*$	$l^*$	$V^*$	$P^*$	$Q^*$	N	{kgf}
<b>WBK 17DF-31</b>	17	70	106	72	60	32	15	80	88	9	14	8.5	45	3	58	M5	10	21900	2240
<b>WBK 20DF-31</b>	20	70	106	72	60	32	15	80	88	9	14	8.5	45	3	58	M5	10	21900	2240
<b>WBK 25DF-31</b>	25	85	130	90	66	33	18	100	110	11	17.5	11	57	4	70	M6	12	28500	2910
<b>WBK 25DFD-31</b>					81	48												46500	4700
<b>WBK 30DF-31</b>	30	85	130	90	66	33	18	100	110	11	17.5	11	57	4	70	M6	12	29200	2980
<b>WBK 30DFD-31</b>					81	48												47500	4850
<b>WBK 35DF-31</b>	35	95	142	102	66	33	18	106	121	11	17.5	11	69	4	80	M6	12	31000	3150
<b>WBK 35DFD-31</b>					81	48												50500	5150
<b>WBK 35DFF-31</b>					96	48												50500	5150
<b>WBK 40DF-31</b>	40	95	142	102	66	33	18	106	121	11	17.5	11	69	4	80	M6	12	31500	3250
<b>WBK 40DFD-31</b>					81	48												51500	5250
<b>WBK 40DFF-31</b>					96	48												51500	5250

**Remarks** 1. Rigidity

Values in the Table are theoretical values obtained from the elastic deformation between the groove and the balls.

2. Starting torque

Starting torque indicates torque due to the preload of the bearing. It does not include seal torque.

3. The tolerance of the shaft bearing seat

We recommend "h5 grade of the fits tolerance.

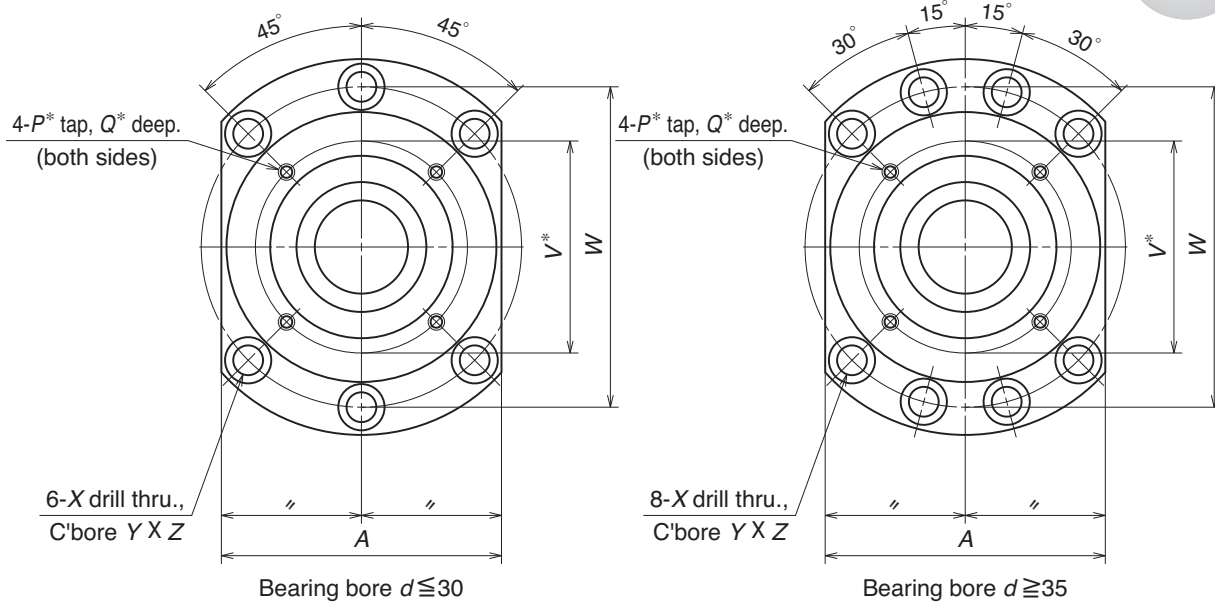

Unit: mm

Permissible axial load		Preload		Axial rigidity		Starting torque		Lock nut			Bearing seat for unit		
N	{kgf}	N	{kgf}	N/ $\mu$ m	{kgf/ $\mu$ m}	N·m	{kgf·m}	M	$D_3$	$L_3$	d	$L_4$	$L_5$
26600	2710	2150	220	750	75	14.0	1.5	M17×1.0	37	18	17	81	23
26600	2710	2150	220	750	75	14.0	1.5	M20×1.0	40	18	20	81	23
40500	4150	3150	320	1000	100	23.0	2	M25×1.5	45	20	25	89	26
81500	8300	4300	440	1470	150	31.0	3					104	
43000	4400	3350	340	1030	105	24.0	2.5	M30×1.5	50	20	30	89	26
86000	8800	4500	460	1520	155	33.0	3					104	
50000	5100	3800	390	1180	120	28.0	3	M35×1.5	55	22	35	92	30
100000	10200	5200	530	1710	175	37.0	4					107	
100000	10200	7650	780	2350	240	55.0	5.5					122	
52000	5300	3900	400	1230	125	28.0	3	M40×1.5	60	22	40	92	30
104000	10600	5300	540	1810	185	38.0	4					107	
104000	10600	7850	800	2400	245	57.0	5.5					122	

**Remarks** 4. Dimensions with \* (asterisk) mark

\*Pilot diameter and tapped screws marked with "asterisk \*" are used for seal unit installation for NSK standard hollow shaft ball screws. They also can be used for dust cover and damper installation.

5. Grease is packed into the bearing. It is not necessary to apply grease before use. We recommend "h5 grade of the fits tolerance.

In addition to the support units, NSK has other components for the ball screw as shown below.

## Lock nuts

Ball screw support bearing must be installed with minimum inclination. NSK lock nuts exclusive for ball screw help to reduce this inclination.

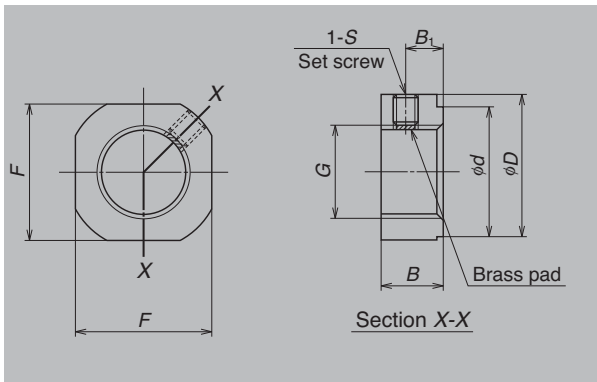

**A Type Shapes and dimensions**

**A Type lock nuts**

Unit: mm

Lock nut reference number	M	D	F	B	d	B <sub>1</sub>	S	Tightening torque N•m (for reference)
<b>WBK06L-01</b>	M6 × 0.75	14.5	12	5	10	2.7	M3, with brass made set piece	245
<b>WBK08L-01</b>	M8 × 1.0	17	14	6.5	13	4	M3, with brass made set piece	490
<b>WBK10L-01</b>	M10 × 1.0	20	17	8	16	5	M4, with brass made set piece	930
<b>WBK12L-01</b>	M12 × 1.0	22	19	8	17	5	M4, with brass made set piece	1350
<b>WBK15L-01</b>	M15 × 1.0	25	22	10	21	6	M4, with brass made set piece	2350
<b>WBK20L-01</b>	M20 × 1.0	35	30	13	26	8	M4, with brass made set piece	4700
<b>WBK25L-01</b>	M25 × 1.5	42	36	16	34	10	M6, with brass made set piece	8400

**Remarks:** Insert a set piece (brass pad) and tighten the securing set screw.

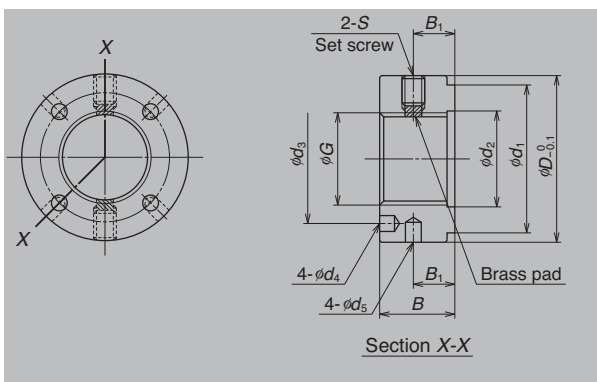

**S Type Shapes and dimensions**

**S Type lock nuts**

Unit: mm

Lock nut reference number	G	D <sub>0.1</sub>	B	d <sub>1</sub>	d <sub>2</sub>	d <sub>3</sub>	d <sub>4</sub>	d <sub>5</sub>	B <sub>1</sub>	S	Tightening torque N•m (for reference)
<b>WBK17L-31</b>	M17 × 1.0	37	18	30	18	27	4.3	4	10	M6	5400
<b>WBK20L-31</b>	M20 × 1.0	40	18	30	21	30	4.3	4	10	M6	7350
<b>WBK25L-31</b>	M25 × 1.5	45	20	40	26	35	4.3	4	11	M6	13200
<b>WBK30L-31</b>	M30 × 1.5	50	20	40	31	40	4.3	5	11	M6	19600
<b>WBK35L-31</b>	M35 × 1.5	55	22	50	36	45	4.3	5	12	M6	29400
<b>WBK40L-31</b>	M40 × 1.5	60	22	50	41	50	4.3	5	12	M6	39200